

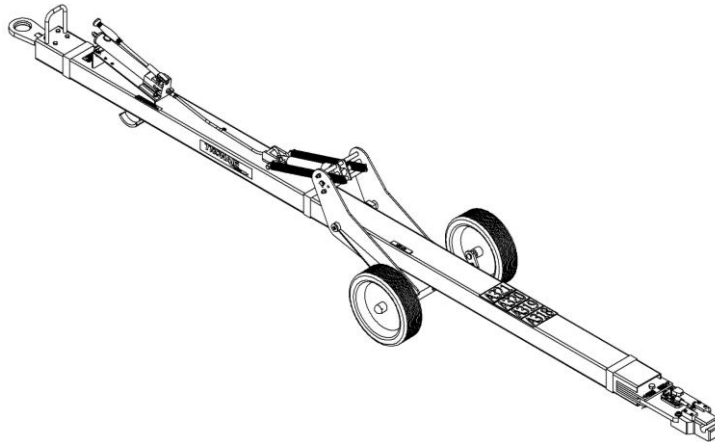

Operation & Service Manual



Model: A003817D
Airbus Towbar
A318, A319, A320, A321



03/2016 – Rev. 02

REVISION
01
02

DATE
12/2014
03/2016

TEXT AFFECTED
Original release
Modified 4.2 Attaching To Aircraft, 5.0 Maintenance and Parts List

TABLE OF CONTENTS**PAGE**

1.0	PRODUCT INFORMATION	1
1.1	DESCRIPTION.....	1
1.2	MODEL & SERIAL NUMBER.....	1
1.3	MANUFACTURER.....	1
2.0	SAFETY INFORMATION	1
2.1	USAGE AND SAFETY INFORMATION.....	1
2.2	SHEAR BOLTS.....	1
3.0	TRAINING	1
3.1	TRAINING REQUIREMENTS.....	1
3.2	OPERATOR TRAINING.....	1
4.0	OPERATION	1
4.1	RAISING AND LOWERING.....	1
4.2	ATTACHING TO AIRCRAFT.....	2
4.3	ATTACHING TO TRACTOR.....	2
5.0	MAINTENANCE	2
5.1	GENERAL.....	2
5.2	RETAINER BOLT TIGHTENING.....	3
6.0	PROVISION OF SPARES	3
6.1	SOURCE OF SPARE PARTS.....	3
6.2	RECOMMENDED SPARE PARTS LISTS.....	3
7.0	IN SERVICE SUPPORT	3
8.0	GAURANTEES/LIMITATION OF LIABILITY	4
9.0	APPENDICES	4

Tronair towbars/heads must only be used with matching Tronair heads/towbars, and Tronair shear pins.

This product can not be modified without the written approval of Tronair, Inc. Any modifications done without written approval voids all warranties and releases Tronair, Inc., its suppliers, distributors, employees, or financial institutions from any liability from consequences that may occur. Only Tronair OEM replacement parts shall be used.

1.0 PRODUCT INFORMATION

1.1 DESCRIPTION

This towbar is designed to push or pull all Airbus A318, A319, A320, A321 aircraft equipped with a 1.50 inch diameter nose gear cross pin. The following operational instructions are only intended to familiarize the operator with the basic functions of the towbar. They are not intended to teach actual pushback procedures or techniques.

1.2 MODEL & SERIAL NUMBER

Reference nameplate on unit

1.3 MANUFACTURER

TRONAIR, Inc.
1740 Eber Road
Holland, Ohio 43528-9794 USA

Telephone: (419) 866-6301 or 800-426-6301
Fax: (419) 867-0634
E-mail: sales@tronair.com
Website: www.tronair.com

2.0 SAFETY INFORMATION

2.1 USAGE AND SAFETY INFORMATION

To insure safe operations please read the following statements and understand their meaning. Also refer to your equipment manufacturer's manual for other important safety information. This manual contains safety precautions which are explained below. Please read carefully.



WARNING! — Warning is used to indicate the presence of a hazard that **can cause severe personal injury, death, or substantial property damage** if the warning notice is ignored.

CAUTION! — Caution is used to indicate the presence of a hazard that **will or can cause minor personal injury or property damage** if the caution notice is ignored.

2.2 SHEAR BOLTS

The towbar is also equipped with shear bolts that are designed to shear when the design limits of the aircraft nose gear are reached. One set of spare shear bolts has been provided with the towbar.

WARNING!



NEVER use other bolts in place of factory supplied shear bolts, aircraft damage may result! In the event that the shear bolts should fail during operation, carefully inspect all parts of the towbar for damage before replacing the shear bolts and returning the towbar to service.

3.0 TRAINING

3.1 TRAINING REQUIREMENTS

The employer of the operator is responsible for providing a training program sufficient for the safe operation of the towbar.

3.2 OPERATOR TRAINING

The operator training should provide the required training for safe operation of the towbar.

NOTE: Maintenance and Trouble Shooting are to be performed by a skilled and trained technician.

4.0 OPERATION

4.1 RAISING AND LOWERING

The towbar is equipped with a hand-operated hydraulic pump/tank which supplies a flow of hydraulic oil to a single acting hydraulic cylinder. This cylinder raises or lowers the wheel carriage assembly to which the tires are attached.

To raise the towbar:

1. Make sure the fill cap on the tank is in the "vent" position and the small control valve located on the side of the pump is in the complete closed (clockwise) position
2. Actuate the pump handle until the desired elevation is achieved
3. To lower the unit, turn the control valve handle counter-clockwise until hydraulic oil flows back into the tank and allows the cylinder to retract
4. Close the valve when the towbar has reached the desired elevation

4.0 OPERATION (continued)

4.2 ATTACHING TO AIRCRAFT

The towbar is equipped with a clamp type attachment head. When attached properly it will allow the aircraft to be pushed or pulled safely.

To attach the towbar to the aircraft:

1. Raise or lower the towbar so that it is level to the ground and at the same height as the nose gear attachment point
2. Open the jaw by pulling the release lever upward and pulling lever backwards
3. Position the lower jaw under the nose gear cross shaft and push lever forward into locked position

4.3 ATTACHING TO TRACTOR

The towbar is equipped with a towing eye that swivels to eliminate any possible binding due to irregular terrain or camber changes in the aircraft nose gear during pushback or towing operations.

To attach the towbar to the tractor:

1. Raise or lower the towbar so that it is level with the ground and at the same height as the tractor hitch point
2. Position the lunette eye into the hitch opening and secure the hitch pin according to the tractor manufacturer's instructions



CAUTION!

The towbar can be safely towed on typical ramp surfaces up to 15 MPH. Exceeding this speed may result in damage to the towbar

5.0 MAINTENANCE

5.1 GENERAL

Towbar maintenance should be done at least once every three months or sooner depending on usage

1. Check shear bolts for wear or a partial shear and replace if necessary. Check bolts by rotating them and looking for movement of the shear plates at the same time
2. Check shear plates for seizing from corrosion and apply a fresh coating of Permatex anti-seize lubricant or equivalent when installing a new head assembly or shear bolts
3. Check tire pressure and inspect for wear or damage
4. Check the hydraulic fluid in the reservoir and maintain the correct level
5. Check for hydraulic leaks
6. Check all nuts, bolts and screws for tightness
7. Check the unit overall for wear or damage
8. Grease hubs through zerk provided in hub

Note: When pressing in new headless press bushings for the shear bolts, assure the chamfer is as shown.

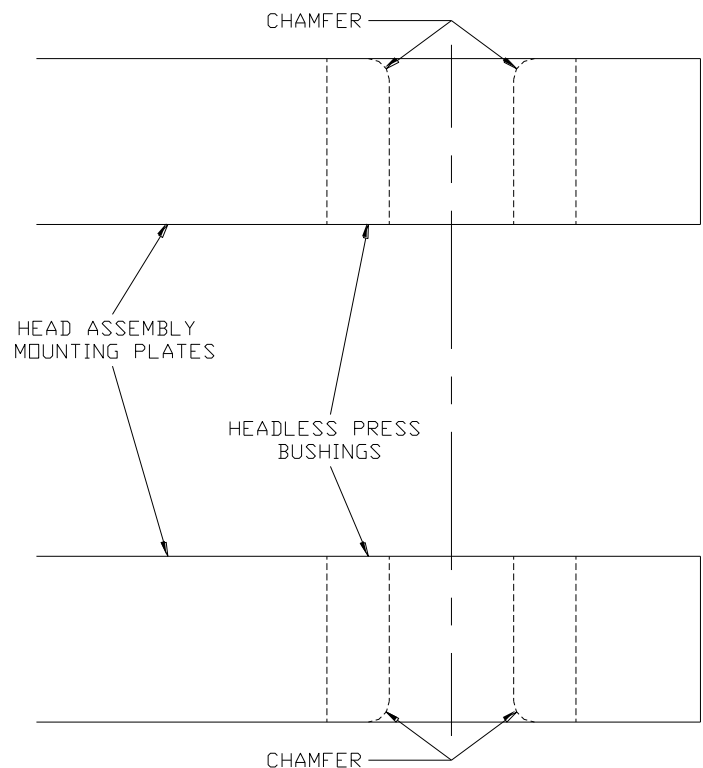

5.0 Maintenance continued on following page.

5.0 MAINTENANCE (continued)

5.2 RETAINER BOLT TIGHTENING

1. Remove shear bolts
2. Tighten .75" retainer bolt until all vertical play is removed and towing head moves free horizontally between head plates on chassis tube weldment

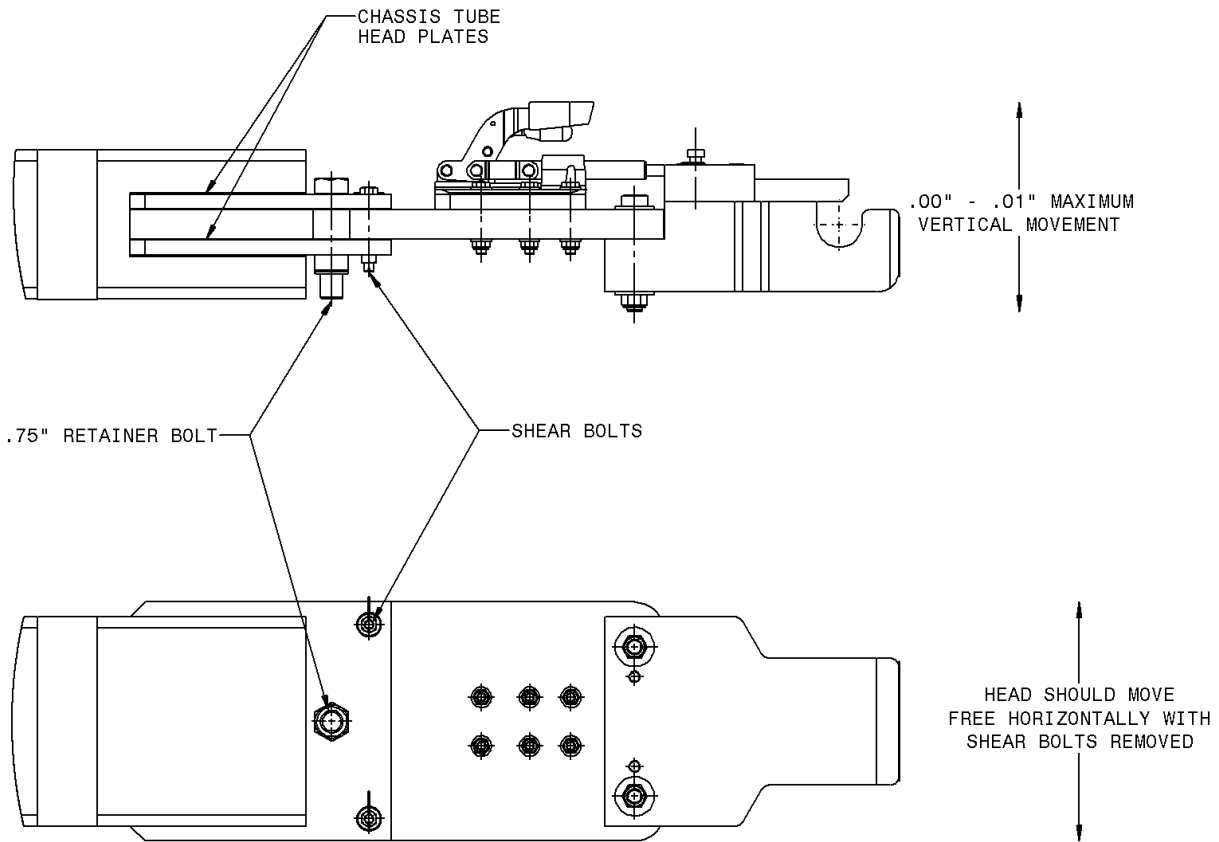

6.0 PROVISION OF SPARES

6.1 SOURCE OF SPARE PARTS

Spare parts may be obtained from the manufacturer:

TRONAIR, Inc.
1740 Eber Road
Holland, Ohio 43528-9794 USA

Telephone: (419) 866-6301 or 800-426-6301
Fax: (419) 867-0634
E-mail: sales@tronair.com
Website: www.tronair.com

6.2 RECOMMENDED SPARE PARTS LISTS

Reference the following page(s) for Replacement Parts and Kits available.

7.0 IN SERVICE SUPPORT

Contact Tronair, Inc. for technical services and information. See Section 1.3 – Manufacturer.

8.0 GAURANTEES/LIMITATION OF LIABILITY

Tronair products are warranted to be free of manufacturing or material defects for a period of one year after shipment to the original customer. This is solely limited to the repair or replacement of defective components. This warranty does not cover the following items:

- a) Parts required for normal maintenance
- b) Parts covered by a component manufacturers warranty
- c) Replacement parts have a 90-day warranty from date of shipment

If you have a problem that may require service, contact Tronair immediately. Do not attempt to repair or disassemble a product without first contacting Tronair, any action may affect warranty coverage. When you contact Tronair be prepared to provide the following information:

- a) Product Model Number
- b) Product Serial Number
- c) Description of the problem

If warranty coverage is approved, either replacement parts will be sent or the product will have to be returned to Tronair for repairs. If the product is to be returned, a Return Material Authorization (RMA) number will be issued for reference purposes on any shipping documents. Failure to obtain a RMA in advance of returning an item will result in a service fee. A decision on the extent of warranty coverage on returned products is reserved pending inspection at Tronair. Any shipments to Tronair must be shipped freight prepaid. Freight costs on shipments to customers will be paid by Tronair on any warranty claims only. Any unauthorized modification of the Tronair products or use of the Tronair products in violation of cautions and warnings in any manual (including updates) or safety bulletins published or delivered by Tronair will immediately void any warranty, express or implied.

The obligations of Tronair expressly stated herein are in lieu of all other warranties or conditions expressed or implied. **Any unauthorized modification of the Tronair products or use of the Tronair products in violations of cautions and warnings in any manual (including updates) or safety bulletins published or delivered by Tronair will immediately void any warranty, express or implied and Tronair disclaims any and all liability for injury (WITHOUT LIMITATION and including DEATH), loss or damage arising from or relating to such misuse.**

9.0 APPENDICES

APPENDIX I Declaration of Conformity

Parts List

When ordering replacement parts/kits, please specify model, serial number and color of your unit.

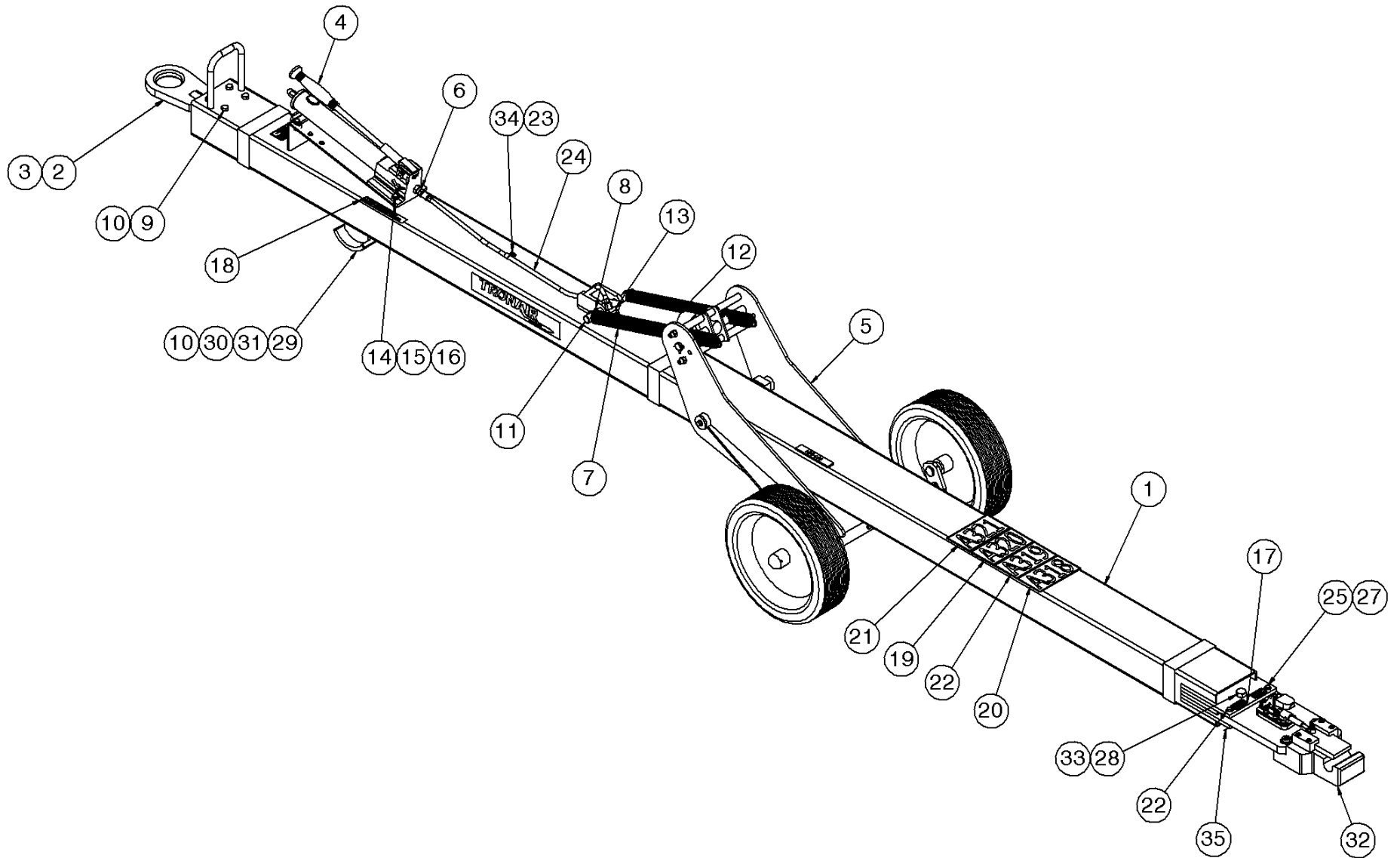

Parts List

When ordering replacement parts/kits, please specify model, serial number and color of your unit.

Item	Part Number	Description	Qty
1	W005222B	WELDMENT, CHASSIS TUBE	1
2	A002574A	ASSEMBLY, SWIVEL LUNETTE	1
3	X-1239	ASSEMBLY, HEAD	1
4	H006322	PUMP, HYD HAND	1
5	A003163A	ASSEMBLY, WHEEL CARRIAGE	1
6	H002112	3/8" NPT X 1/4" F. STR. HYD. SWIVEL	1
7	A003021A	ASSY, 1/4" X 38" LG. HYD. HOSE	1
8	H005115	CYLINDER, HYDRAULIC BLACK	1
9	H005116	SPRING	2
10	H001445	1/4" NPT X 1/4 F. 90° HYD. SWIVEL	1
11	P054191A	PIN, CYLINDER MOUNT 1.0"	1
12	G-1301-11	PIN, 3/16 X 1.5" LG. COTTER	2
13	G-1100-107012	BOLT, 3/8-16 X 1-1/4" HEX HD GR 5	4
14	G-1100-109060	BOLT, 1/2-13 X 6.0" HEX HD GR 5	4
15	G-1202-1090	STOPNUT, 1/2-13 ELASTIC	6
16	H005184	SHEARBOLT, 5/16" N.F. X 2.50" LG.	4
17	G-1200-1065	NUT, 5/16-24 HEX	4
18	H004560	PIN, COTTER, .063 X 1.00, ZP	4
19	H001424	CAPSCREW, .75 NC X 3.50, GR 5, ZP	1
20	G-1202-1110	STOPNUT, 3/4-10 ELASTIC	1
21	G-1202-1070	STOPNUT, 3/8-16 ELASTIC	4
22	P057367A	FLAT, SPACER	2
23	G-1250-1070N	FLATWASHER. 3/8 NARROW	4
24	H005871	LABEL, SHEAR BOLT	3
25	H005872	LABEL, OPEN VALVE BEFORE TOWING	1
26	P058792A	DECAL, "A320"	1
27	P066927A	DECAL, "A318"	1
28	P067887A	DECAL, "A321"	1
29	P064669A	DECAL, "A319"	1
30	H001300	1/2" VINYL COATED CLAMP	1
31	Z-9092-01	WELDMENT, TOE GUARD	1
32	G-1250-1090N	FLATWASHER. 1/2 NARROW	4
33	G-1100-109016	BOLT, 1/2-13 X 1-3/4" HEX HD GR 5	2
34	H005650	SCREW, SELF-TAP AB, .25 X 1.00	1
35	H005881	5/16" X 3/4" X 1/2" LG. HEADLESS PRESS BUSHING	4

Parts List

When ordering replacement parts/kits, please specify model, serial number and color of your unit.

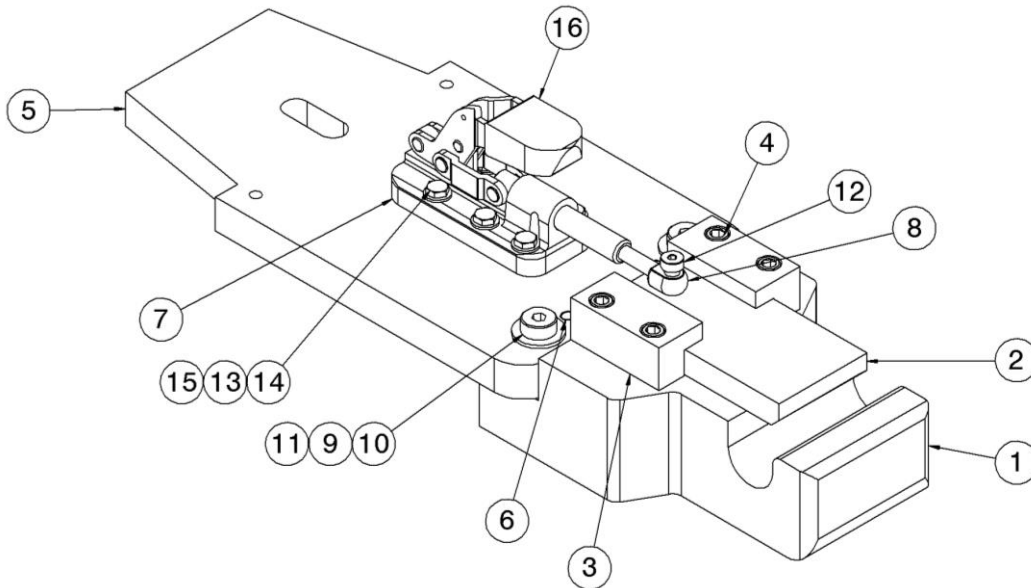

Item	Part Number	Description	Qty
1	J-6205	MACHINE, HEAD	1
2	J-6209	PLATE, SLIDER	1
3	J-4485	GUIDE, SLIDE	2
4	G-1151-107213	SCREW, 3/8-16 X 1-3/8" HEX HD CAP GR 8	4
5	J-6206	PLATE, MACHINED HEAD	1
6	G-1314-82	PIN, 3/8 X 2-1/2 SST DOWEL	2
7	J-6207	SPACER	1
8	H-2943	END, ROD	1
9	G-1250-1100N	FLATWASHER. 5/8 NARROW	4
10	G-1155-109226	SCREW, 5/8 X 2-3/4" LG SOCKET HD SHOULDER	2
11	G-1202-1090	STOPNUT, 1/2-13 ELASTIC	2
12	G-1155-106206	SCREW, 3/8" X 3/4" LG. HEX SOCKET HEAD SHOULDER	1
13	G-1250-1060N	FLATWASHER. 5/16 NARROW	12
14	G-1100-106522	BOLT, 5/16-24 X 2-1/4" LG. HEX HD GR 5	6
15	G-1202-1065	STOPNUT, 5/16-24 ELASTIC	6
16	H-2923	CLAMP, TOGGLE	1

Parts List

When ordering replacement parts/kits, please specify model, serial number and color of your unit.

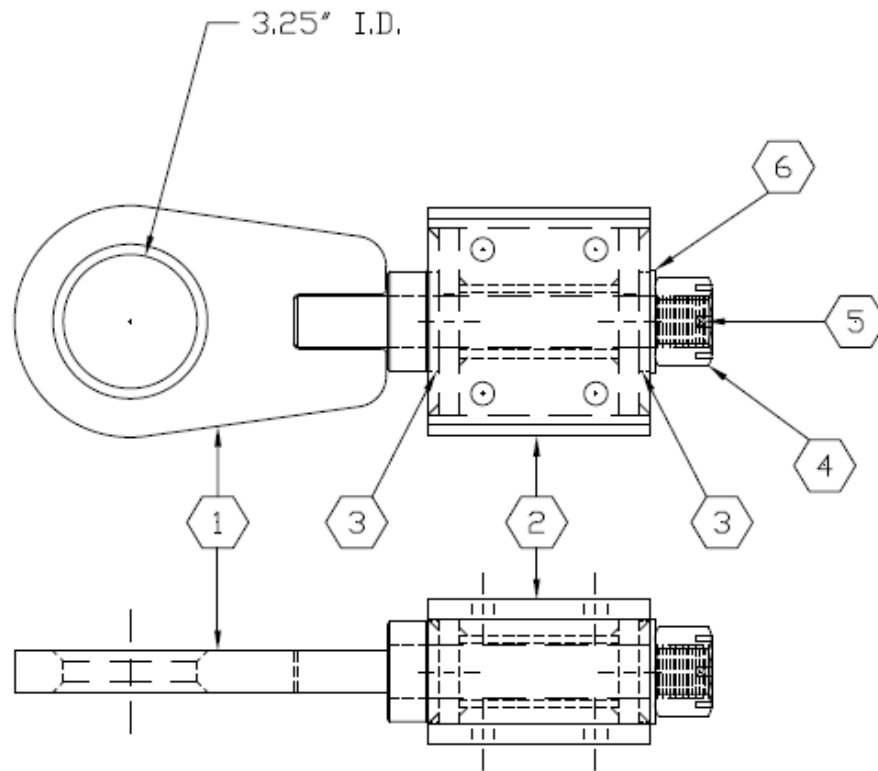

Item	Part Number	Description	Qty
	A002574A	Swivel Lunette Assembly; consists of:	
1	W003887A	Hitch Pin Weldment	1
2	W003888A	Pin Block Weldment	1
3	P054190A	Pivot Washer	2
4	H001177	1-1/4" NF Slotted Nut	1
5	H001219	3/16" x 2" Lg. Cotter Pin	1
6	H004701	1-1/4" SAE Washer	1

Parts List

When ordering replacement parts/kits, please specify model, serial number and color of your unit.

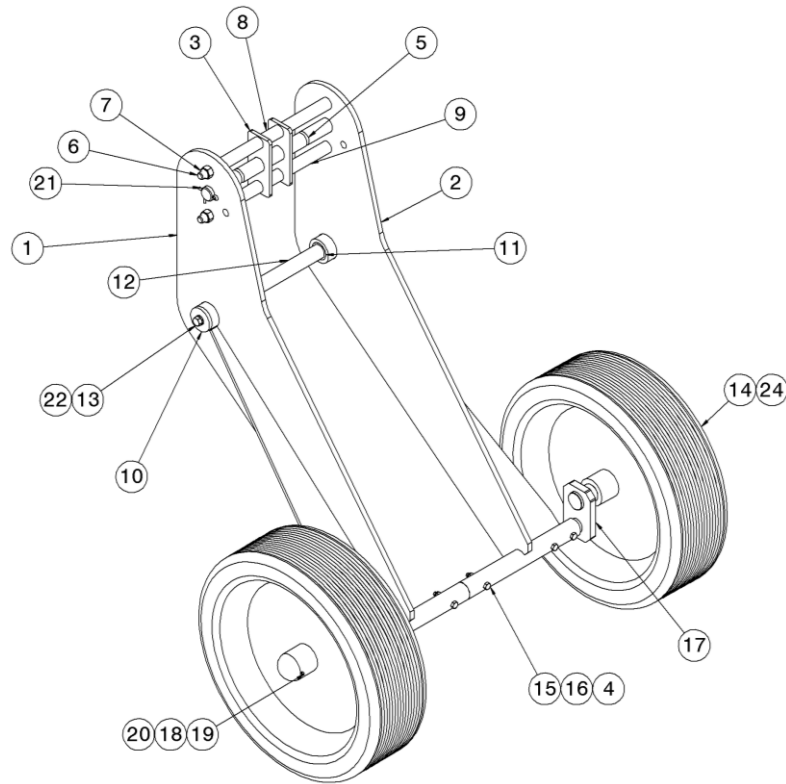

Item	Part Number	Description	Qty
1	Z-8603	Weldment, Wheel Plate	1
2	Z-8604	Weldment, Wheel Plate	1
3	P054192A	Hyd. Cyl. Mount Plate	2
4	P054193A	Spindle Tube Connector	1
5	P054194A	Cyl. Mount Pin	1
6	P054195A	Spacer Mount Rod	2
7	H001001	1/2" Nylok Nut	4
8	P054196A	Spacer Tube	2
9	P054197A	Spacer Tube	4
10	P054198A	Wheel Washer	2
11	P054199A	Bushing, 1.003 X 1.253 X 1.750	2
12	P054200A	Wheel Assembly Mount Rod	1
13	H001251	Capscrew, .38 NC X 1.25, ZP	2
14	H005813	Wheel, 4.80 X 8 Pneumatic	2
15	H001154	Capscrew, .25 NC X 1.75, GR 5,	6
16	H001027	.25" Nylok Nut, ZP	6
17	W004605D	Weldment, Offset Axle	2
18	H001286	Nut, Slotted, .75 NF, Gr 5, ZP	2
19	H001005	Pin, Cotter, .125 X 2.00, ZP	2
20	H004923	Bushing, Mach, .75 x 18 G, NR,	2
21	H001148	Pin, .188 X 1.5, ZP	2
22	H004977	Washer, Lock, .375, ZP	2
23	H001164	Bushing, Mach, 1.00 x 14 G, NR,	REF.
24	H001296	Grease Zerk	2



APPENDIX - I

**Declaration
of
Conformity**



Declaration of Conformity

The design, development and manufacture is in accordance with European Community guidelines

Towbar
A003817D

Relevant provisions complied with by the machinery:
2006/42/EC

Relevant standards complied with by the machinery:
EN ISO 12100-1

Identification of person empowered to sign on behalf of the manufacturer:

A handwritten signature in black ink, reading "David L. Kiehl". The signature is written in a cursive style and is positioned above a horizontal line.

Quality Assurance Representative