

**Model: AGE13604A
Ground Test Motor**



01/2020 – Rev. 04

REVISION	DATE	TEXT AFFECTED
01	07/2014	Original Release
02	10/2014	Modified Parts List
03	12/2019	Major revision
04	01/2020	Modified Parts List

TABLE OF CONTENTS

PAGE

1.0	PRODUCT INFORMATION	1
1.1	DESCRIPTION	1
1.2	MODEL & SERIAL NUMBER	1
1.3	MANUFACTURER	1
1.4	LIST OF DRAWINGS	1
1.5	RELEVANT STANDARDS	1
1.6	OVERVIEW	1
1.7	MATING COUPLINGS AND PLUGS:	1
2.0	SAFETY INFORMATION	2
2.1	USAGE AND SAFETY INFORMATION	2
2.2	EXPLANATION OF WARNING AND DANGER SIGNS	2
2.3	COMPONENT SAFETY FEATURES	2
2.4	FEATURES FOR OPERATOR SAFETY	2
2.5	PERSONAL PROTECTIVE EQUIPMENT	2
2.6	SAFETY GUIDELINES	2
2.7	CONDITIONS FOR SAFE USE	2
2.8	TECHNICAL EXPERTISE	2
2.8.1	Installation	2
2.8.2	Operation	2
2.8.3	Maintenance	2
2.9	ADDITIONAL SAFETY INFORMATION	2
3.0	PREPARATION PRIOR TO FIRST USE	3
3.1	ASSEMBLY	3
3.2	INSTALLATION	3
3.2.1	Installation Requirements	3
3.2.2	Personnel Requirements (Technical Expertise) For Installation	3
3.2.3	Specifications And Standards	3
3.2.4	Required Materials For Installation	3
3.2.5	Required Installation Tools	3
3.2.6	Installation Procedure	3
3.2.7	Inspection And Testing Procedure Upon Installation	3
4.0	TRAINING	4
4.1	TRAINING REQUIREMENTS	4
4.2	TRAINING PROGRAMS, MANUALS, METHODS, SUPERVISORS, AND OPERATORS	4
4.3	OPERATOR TRAINING	4
5.0	OPERATION	4
5.1	OPERATING PARAMETERS	4
5.2	NUMERICAL VALUES AND LIMITS	4
5.2.1	General	4
5.2.2	Dimensions	4
5.3	FEATURES	4
5.4	PERSONAL PROTECTIVE EQUIPMENT	4
5.5	CHECKS PRIOR TO START UP	4
5.6	START UP PROCEDURE	4
5.7	OPERATING PROCEDURES	5
4.8	STOPPING PROCEDURES	5
5.9	EMERGENCY STOPPING PROCEDURES	5
6.0	PACKAGING AND STORAGE	5
6.1	PACKAGING REQUIREMENTS	5
6.2	METHODS OF HANDLING	5
6.3	STORAGE	5
6.4	STORAGE SPACE AND HANDLING FACILITIES	5
7.0	TRANSPORTATION	5
7.1	HANDLING POINTS	5
7.2	WEIGHT	5
8.0	MAINTENANCE	6
8.1	DESCRIPTION OF EQUIPMENT	6
8.2	RECOMMENDED SPARE PARTS	6
8.3	INSPECTION POINTS	6
8.4	SCHEDULED MAINTENANCE	6
8.5	TECHNICAL SPECIFICATIONS	6
8.6	MAINTENANCE PERSONNEL REQUIREMENTS	6
8.7	TROUBLESHOOTING GUIDE	6
9.0	PROVISION OF SPARES	6

9.1 SOURCE OF SPARE PARTS..... 6

9.2 RECOMMENDED SPARE PARTS LISTS 6

10.0 IN SERVICE SUPPORT..... 6

11.0 GUARANTEES/LIMITATION OF LIABILITY 7

12.0 APPENDICES 7

This product can not be modified without the written approval of Tronair, Inc. Any modifications done without written approval voids all warranties and releases Tronair, Inc., its suppliers, distributors, employees, or financial institutions from any liability from consequences that may occur. Only Tronair OEM replacement parts shall be used.

1.0 PRODUCT INFORMATION

1.1 DESCRIPTION

The Ground Test Motor (GTM), powered by a suitable hydraulic cart, is used to back drive the Ram Air Turbine (RAT) during ground checkout. The ground tests are to be performed in accordance with the airframer's AMM and RAT manufacturer's instructions.

This Ground Test Motor is to be operated only by qualified trained technicians.

This Operation and Service Manual is to be used only by qualified trained technicians.

1.2 MODEL & SERIAL NUMBER

Ground Test Motor
Model AGE13604A
Serial Number located on nameplate
Date of manufacture located on nameplate

1.3 MANUFACTURER

TRONAIR, Inc.
1 Air Cargo Pkwy East
Swanton, Ohio 43558 USA

Telephone: (419) 866-6301 or 800-426-6301
Fax: (419) 867-0634
E-mail: sales@tronair.com
Website: www.tronair.com

1.4 LIST OF DRAWINGS

Outline Dimensions

1.5 RELEVANT STANDARDS

1. The GTM has been designed to comply with the following directives:
 - 2006/42/EC: Machinery Directive
2. The following standards were used as guides to design the GTM:
 - EN ISO 12100-1
 - BS EN 982:1996
 - prEC 1915-1:1995

1.6 OVERVIEW

The GTM is composed of a hydraulic motor, and adaptor plate, a splined adaptor shaft, two hoses approximately 20 foot (6.1 m) long with couplings for connection to a hydraulic cart, a strap and hook assembly for supporting the hose by the fuselage, and a storage case.

1.7 MATING COUPLINGS AND PLUGS:

CouplingsInlet: Tronair # N-2617-05Outlet: Tronair # N-2617-07
PlugsInlet: Tronair # N-2673-05Outlet: Tronair # N-2673-07

2.0 SAFETY INFORMATION

2.1 USAGE AND SAFETY INFORMATION

To insure safe operations please read the following statements and understand their meaning. Also refer to your equipment manufacturer's manual for other important safety information. This manual contains safety precautions which are explained below. Please read carefully.



WARNING!

Warning is used to indicate the presence of a hazard that can cause **severe personal injury, death, and/or substantial property damage** if the Warning Notice is ignored.



CAUTION!

Caution is used to indicate the presence of a hazard, which will or can cause **minor personal injury or property damage** if the Caution Notice is ignored.

2.2 EXPLANATION OF WARNING AND DANGER SIGNS

- Misuse of machine can cause personal injury and/or property damage.
- Operation of the GTM must be in accordance with this manual, and the Airframe/RAT Manufacturer's Instructions

2.3 COMPONENT SAFETY FEATURES

- Pressure rating safety factors are in accordance with EN 982:1996.

2.4 FEATURES FOR OPERATOR SAFETY

- No additional features are included for operator safety. Safeguards against hazards created during the ground checkout must be provided by others in accordance with the Airframe/RAT Manufacturer's Instructions, and all applicable regulations.

2.5 PERSONAL PROTECTIVE EQUIPMENT

- Operators must use personal protective equipment in accordance with their employer's requirements.
- See airframe/RAT manufacturer's information on maximum sound levels during ground checkout.

2.6 SAFETY GUIDELINES

- Any uses other than those identified in Section 1.1 of this manual are prohibited.

2.7 CONDITIONS FOR SAFE USE

- Temperature Range: -10° F thru +120° F (-23° C thru +49° C)
- Operate in accordance with airframe/RAT manufacturer's instructions.

2.8 TECHNICAL EXPERTISE

2.8.1 Installation

The installation of this tool is to be completed by qualified aircraft technicians. See Section 6 for installation information.

2.8.2 Operation

This tool is to be used by skilled and trained aircraft technicians in accordance with this manual, and the airframe/RAT manufacturer's instructions. See Section 7 for Operation Instructions. Proper operation of the hydraulic power unit is required.

2.8.3 Maintenance

This machine is to be maintained by qualified maintenance personnel. See Section 9 for maintenance information.

2.9 ADDITIONAL SAFETY INFORMATION

Safeguards in accordance with airframe/RAT manufacturer's instruction must be used.



WARNING!

- **ALWAYS follow the airframe/RAT manufacturer's instructions when testing the RAT.**
- **ALWAYS use applicable safety equipment required for RAT ground checkout tests.**

3.0 PREPARATION PRIOR TO FIRST USE

3.1 ASSEMBLY

The GTM is shipped assembled and ready for use.

3.2 INSTALLATION

3.2.1 Installation Requirements

Hydraulic Cart requirements: 20 gpm @ 3,000 psi (76 lpm @ 207 bar)



WARNING!

Do not exceed 3,150 psi (217.9 bar) rated supply pressure to motor.

3.2.2 Personnel Requirements (Technical Expertise) For Installation

This tool is to be installed and used by qualified aircraft mechanics in accordance with this manual, and employer and airframe/RAT manufacturer instructions.

3.2.3 Specifications And Standards

- Motor/Adaptor/Spline/Fitting Weight: Approximately 9 lbs (4 kg)
- Hose Length: Approximately 20 ft (6.1 m)
- Fluid: Aviation Phosphate Ester Type IV or V
- Mating couplings: Includes GSE hose mating couplings
- For use with the following Hamilton Sundstrand LRU part numbers:
 - 1703781** basic and subsequent builds
 - 1707326** basic and subsequent builds
 - 1709479** basic and subsequent builds

3.2.4 Required Materials For Installation

- 20 gpm @ 3,000 psi (76 lpm @ 207 bar) Hydraulic Cart
- Aviation Phosphate Ester Type IV or V hydraulic fluid as required

3.2.5 Required Installation Tools

Calibrated torque wrench

3.2.6 Installation Procedure

NOTE: See Section 7.5 Preparation Prior to First Use before attaching the GTM to the RAT.

3. Remove any protective covers on the RAT generator/GTM interface.
4. Remove the GTM from the case by carefully un-coiling the hoses, and lift the motor out of the case. Do NOT lift motor by the hoses as premature failure may occur.
5. Attach the GTM to the interface on the back of the RAT generator, with seal drain facing downward, while ensuring the splined shaft properly engages the mating female spline in the RAT generator shaft.
6. Secure the GTM to the RAT by tightening the three (3) captive 1/4-28 fasteners to 48 – 53 lb-in (5.4 – 6.0 N-m).
7. Remove the cap from the seal drain.
8. The support cable must be hooked to the RAT aft compartment opening. Adjust the hose clamp location to assure the hoses are fully supported by the strap.
9. Connect the pressure hose to the proper coupling directly on the hydraulic cart (supply). Do NOT use additional lengths of hose as diminished performance may occur.
10. Connect the return hose to the proper coupling directly on the hydraulic cart (return to tank). Do NOT use additional lengths of hose as diminished performance may occur.
11. The pressure and return ball valves on the hydraulic power unit MUST be fully open.

3.2.7 Inspection And Testing Procedure Upon Installation

- Verify that the seal drain cap has been removed
- Verify that the couplings are properly engaged.
- Verify that all fasteners on the GTM are properly tightened.
- Verify that all hydraulic connections are tight.
- Verify that the support is properly adjusted.
- Verify that the return valves on the hydraulic power unit are fully open before applying supply pressure.

4.0 TRAINING

4.1 TRAINING REQUIREMENTS

- GTM operators **MUST** be properly trained in all aspects of aircraft RAT ground checkout.
- It is the employer's responsibility to ensure that the operator is qualified to use this tool.
- This GTM Operation and Maintenance Manual does not provide qualified training to perform aircraft RAT ground checkout tests.

4.2 TRAINING PROGRAMS, MANUALS, METHODS, SUPERVISORS, AND OPERATORS

- Tronair does not provide training materials beyond the scope of this manual.
- It is the employer's responsibility to provide any training requirements beyond the scope of this manual.

4.3 OPERATOR TRAINING

The operator training should provide the required training for safe operation of the unit.

NOTE: Maintenance and Trouble Shooting are to be performed by a skilled and trained technician.

5.0 OPERATION

5.1 OPERATING PARAMETERS

- Ground checkout tests
- Temperature Range: -10° F thru +120° F (-23° C thru +49° C)

5.2 NUMERICAL VALUES AND LIMITS

5.2.1 General

- Phosphate Ester fluid
- Fluid consumption 20 gpm (76 lpm)
- Maximum Pressure 3,150 psi (217.9 bar)

5.2.2 Dimensions

- Case..... 35 in (889 mm) long x 31 ins (787 mm) wide x 17 in (432 mm) high
- Pressure Supply Hose 20 ft (6.1 m) long
- Return Hose..... 20 ft (6.1 m) long
- Motor weight..... 5.5 lbs (2.5 kg)

5.3 FEATURES

- The hydraulic motor provides power and speed capabilities consistent with the requirements of the ground checkout procedure in a weight and envelope that can safely be supported by the RAT and support cable.
- The GTM tool provides a custom designed adaptor plate and splined shaft developed in conjunction with Hamilton Sundstrand for proper fit and operation.
- The specially designed storage case can be used for shipping the tool.

5.4 PERSONAL PROTECTIVE EQUIPMENT

Personal protective equipment must be used in accordance with employer's instructions, and local and federal regulations.

5.5 CHECKS PRIOR TO START UP

- Verify that the seal drain cap has been removed
- Verify that the couplings are properly engaged.
- Verify that all fasteners on the GTM are properly tightened.
- Verify that all hydraulic connections are tight.
- Verify that the return valve on the ground cart is fully open before applying supply pressure.
- Verify that the support is properly installed and supporting the hoses.

5.6 START UP PROCEDURE

Ensure that steps in 7.7 have been completed.

CAUTION!



To prevent personal injury and/or damage to aircraft:

- **ALWAYS** follow the airframe/RAT manufacturer's instructions when testing the RAT.
- **ALWAYS** use applicable safety equipment required for RAT ground checkout tests.

5.0 OPERATION (continued)**5.7 OPERATING PROCEDURES****Basic Operation:**

Use the hydraulic cart to power the GTM in accordance with the instruction provided with the cart, and the ground checkout procedures for the RAT provided by the airframe/RAT manufacturer.

Always have the bypass valve on the HPU open when starting the unit. Always slowly increase or decrease the pressure control. Always open the bypass valve on the HPU before stopping the HPU.

4.8 STOPPING PROCEDURES

To stop the GTM, reduce or remove the supply of pressurized fluid to the motor.

5.9 EMERGENCY STOPPING PROCEDURES

Follow the emergency stopping procedures provided in the instructions for the hydraulic test cart, and the airframe/RAT ground checkout procedures.

6.0 PACKAGING AND STORAGE**6.1 PACKAGING REQUIREMENTS**

- This tool is provided with a storage case that is suitable for shipment.

6.2 METHODS OF HANDLING

- The GTM case can be rolled freely by hand.
- No provisions for lifting by overhead crane are provided.
- The RAT ground test motor is a high speed, precision test unit that needs to be handled with care when stowing, carrying, handling or installing the unit. Both the motor and hoses must be supported.

6.3 STORAGE

- The GTM is suitable for indoor storage. Protect the tool from moist environments.

6.4 STORAGE SPACE AND HANDLING FACILITIES

- Minimum: 35 inches length x 31 inches width x 17 inches height (889 x 787 x 432 mm)
- No specific handling facilities are required.

7.0 TRANSPORTATION**7.1 HANDLING POINTS**

- Handles are provided on three sides of the case for lifting and pulling.

7.2 WEIGHT

- 60 lbs (27 kg)

8.0 MAINTENANCE

8.1 DESCRIPTION OF EQUIPMENT

Hydraulic Motor – Rebuild services available

8.2 RECOMMENDED SPARE PARTS

Part Number	Description	Qty
R-2102	Shaft, Adaptor	1
TF-1117-05*240	Hose, Return	1
TF-1117-03*240	Hose, Pressure	1
H-2674	Clip, Retaining	1
HC-2178	Motor, Hydraulic	1

8.3 INSPECTION POINTS

- Inspect splined shaft for wear
- Inspect hose connections for leaks

8.4 SCHEDULED MAINTENANCE

No specific maintenance is required.

8.5 TECHNICAL SPECIFICATIONS

- Aviation Phosphate Ester Fluid, Type IV or V
- Fluid consumption20 gpm (76 lpm)
- Fluid pressure3,000 psi (207 bar)
- Operating speed.....7,200 – 8,000 rpm

8.6 MAINTENANCE PERSONNEL REQUIREMENTS

Maintenance personnel should have a basic knowledge of hydraulic systems.

8.7 TROUBLESHOOTING GUIDE

PROBLEM	PROBABLE CAUSE	REMEDY
GTM does not turn the turbine assembly	Turbine lock on	Unlock RAT turbine
	Low supply pressure	Ensure hydraulic cart is operating correctly
	No flow to motor	Open valves on hydraulic cart
	GTM improperly mounted	Correct mounting of GTM
	Turbine cannot be turned	Repair RAT turbine

9.0 PROVISION OF SPARES

9.1 SOURCE OF SPARE PARTS

Spare parts may be obtained from the manufacturer:

TRONAIR, Inc.
1 Air Cargo Pkwy East
Swanton, Ohio 43558 USA

Telephone: (419) 866-6301 or 800-426-6301
Fax: (419) 867-0634
E-mail: sales@tronair.com
Website: www.tronair.com

9.2 RECOMMENDED SPARE PARTS LISTS

Reference the following page(s) for Replacement Parts and Kits available.

10.0 IN SERVICE SUPPORT

Contact Tronair, Inc. for technical services and information. See Section 1.3 – Manufacturer.

11.0 GUARANTEES/LIMITATION OF LIABILITY

Tronair products are warranted to be free of manufacturing or material defects for a period of one year after shipment to the original customer. This is solely limited to the repair or replacement of defective components. This warranty does not cover the following items:

- a) Parts required for normal maintenance
- b) Parts covered by a component manufacturers warranty
- c) Replacement parts have a 90-day warranty from date of shipment

If you have a problem that may require service, contact Tronair immediately. Do not attempt to repair or disassemble a product without first contacting Tronair, any action may affect warranty coverage. When you contact Tronair be prepared to provide the following information:

- a) Product Model Number
- b) Product Serial Number
- c) Description of the problem

If warranty coverage is approved, either replacement parts will be sent or the product will have to be returned to Tronair for repairs. If the product is to be returned, a Return Material Authorization (RMA) number will be issued for reference purposes on any shipping documents. Failure to obtain a RMA in advance of returning an item will result in a service fee. A decision on the extent of warranty coverage on returned products is reserved pending inspection at Tronair. Any shipments to Tronair must be shipped freight prepaid. Freight costs on shipments to customers will be paid by Tronair on any warranty claims only. Any unauthorized modification of the Tronair products or use of the Tronair products in violation of cautions and warnings in any manual (including updates) or safety bulletins published or delivered by Tronair will immediately void any warranty, express or implied.

The obligations of Tronair expressly stated herein are in lieu of all other warranties or conditions expressed or implied. **Any unauthorized modification of the Tronair products or use of the Tronair products in violations of cautions and warnings in any manual (including updates) or safety bulletins published or delivered by Tronair will immediately void any warranty, express or implied and Tronair disclaims any and all liability for injury (WITHOUT LIMITATION and including DEATH), loss or damage arising from or relating to such misuse.**

12.0 APPENDICES

APPENDIX I Declaration of Conformity

Parts List

When ordering replacement parts/kits, please specify model, serial number and color of your unit.

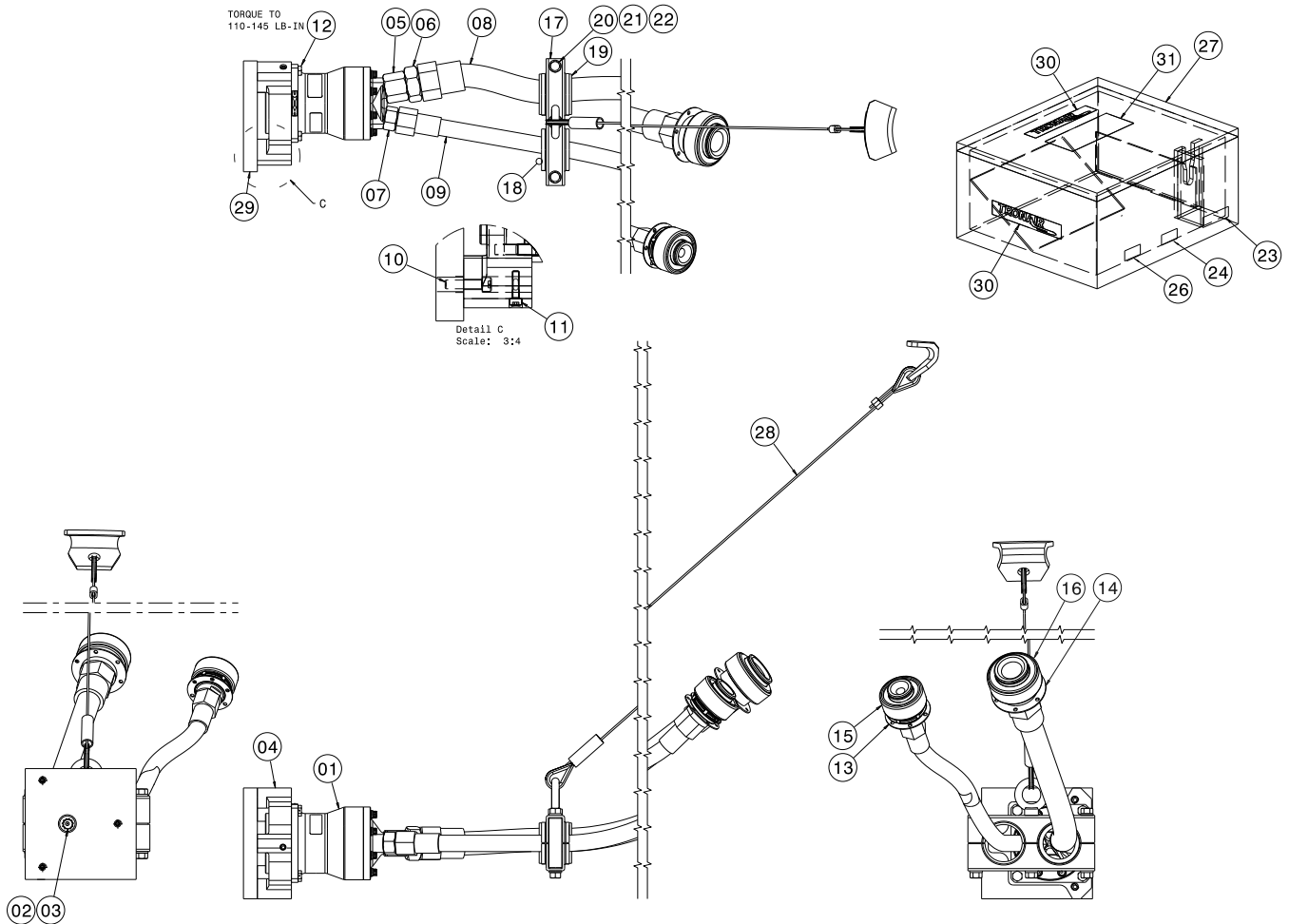

Item	Part Number	Description	Qty
1	HC-2178	Motor, Hydraulic	1
2	H-2674	Clip, Retaining	1
3	R-2102	Shaft, Adaptor	1
4	J-3446	Plate, Adaptor	1
5	N-2709-06-S-E	Reducer, Straight Thread	1
6	N-2007-42-S-E	Connector, Straight Thread	1
7	N-2007-41-S-E	Connector, Straight Thread	1
8	TF-1117-05*240	Hose Assembly (Phosphate Ester)	1
9	TF-1117-03*240	Hose Assembly (Phosphate Ester)	1
10	G-1478-105110	Screw, 1/4-28 Hex Soc Hd Cap	3
11	G-1478-103006	Screw, #10-24 Hex Soc Hd Cap	3
12	G-1110-5H-5A	Bolt, Steel AN	4
13	N-2608-01	Coupling, Half QD	1
14	N-2854-20	Coupling, Half QD	1
15	N-2685-12	Cap, Dust	1
16	N-2685-20	Cap, Dust	1
17	HC-2185-01	Clamp, Multiclamp	1

Parts List

When ordering replacement parts/kits, please specify model, serial number and color of your unit.

Item	Part Number	Description	Qty
18	HC-2186-07	Bushing, Split-Multiclamp	1
19	HC-2186-10	Bushing, Split-Multiclamp	1
20	HC-2187-03	Nut, Stacking	3
21	G-1251-1070R	Lockwasher, 3/8 Regular	5
22	G-1100-107010	Bolt, HH, Grade 5, 3/8-16 x 1" long	5
23	V-1977	Label, Fluid, PE	1
24	V-1001	Label, Made In USA	1
26	V-2287	Label, Serial Number	1
27	H-3767	Case, Storage-Shipping	1
28	Z-5670	Assembly, Hose Hanging Cable	1
29	J-3460	Cover, Plate	1
30	V-1033	Label, Tronair	3
31	V-2527	Label, AGE13604	1



APPENDIX I

Declaration of Conformity



DECLARATION of CONFORMITY

The design, development and manufacture is in accordance with European Community guidelines

GROUND TEST TOOL
AGE13604A

Relevant directive complied with by the machinery:
2006/42/EC

Relevant standards complied with by the machinery:
EN ISO 4413:2010
APR 1247D
EN 1915-1:2013

Identification of person empowered to sign on behalf of the Manufacturer:

A handwritten signature in cursive script that reads "Patrick Finch". The signature is written in black ink and is positioned above a horizontal line.

Quality Assurance Representative