

Model: AGE17078
Ground Test Tool
Airbus A380 Ram Air Turbine



05/2015 – Rev. 03

For Spare Parts, Operations & Service Manuals or Service Needs
Scan the QR code or visit Tronair.com/aftermarket



REVISION	DATE	TEXT AFFECTED
01	07/2014	Original Release
02	01/2015	Major Revision
03	05/2015	Major Revision

TABLE OF CONTENTS

PAGE

1.0	PRODUCT INFORMATION	1
1.1	DESCRIPTION.....	1
1.2	MODEL & SERIAL NUMBER.....	1
1.3	MANUFACTURER.....	1
1.4	FUNCTION.....	1
1.5	LIST OF DRAWINGS.....	1
1.6	RELEVANT STANDARDS.....	1
1.7	OVERVIEW.....	1
1.8	MATING COUPLINGS AND PLUGS.....	1
2.0	SAFETY INFORMATION	2
2.1	USAGE AND SAFETY INFORMATION.....	2
2.2	EXPLANATION OF WARNING AND DANGER SIGNS.....	2
2.3	COMPONENT SAFETY FEATURES.....	2
2.4	FEATURES FOR OPERATOR SAFETY.....	2
2.5	PERSONAL PROTECTIVE EQUIPMENT.....	2
2.6	SAFETY GUIDELINES.....	2
2.7	CONDITIONS FOR SAFE USE.....	2
2.8	TECHNICAL EXPERTISE.....	2
2.8.1	Installation.....	2
2.8.2	Operation.....	2
2.8.3	Maintenance.....	2
2.9	ADDITIONAL SAFETY INFORMATION.....	2
3.0	TRAINING	3
3.1	TRAINING REQUIREMENTS.....	3
3.2	TRAINING PROGRAMS, MANUALS, METHODS, SUPERVISORS, AND OPERATORS.....	3
3.3	OPERATOR TRAINING.....	3
4.0	ASSEMBLY	3
5.0	INSTALLATION	3
5.1	INSTALLATION REQUIREMENTS.....	3
5.2	PERSONNEL REQUIREMENTS (TECHNICAL EXPERTISE) FOR INSTALLATION.....	3
5.3	SPECIFICATIONS AND STANDARDS.....	3
5.4	REQUIRED MATERIALS FOR INSTALLATION.....	3
5.5	INSTALLATION PROCEDURE.....	3
5.6	INSPECTION AND TESTING PROCEDURE UPON INSTALLATION.....	4
6.0	OPERATION	4
6.1	OPERATING PARAMETERS.....	4
6.2	NUMERICAL VALUES AND LIMITS.....	4
6.2.1	General.....	4
6.2.2	Dimensions.....	4
6.3	FEATURES.....	4
6.4	PERSONAL PROTECTIVE EQUIPMENT.....	4
6.5	CHECKS PRIOR TO START UP.....	4
6.6	START UP PROCEDURE.....	4
6.7	OPERATING PROCEDURES.....	4
6.7.1	Basic Operation.....	4
6.8	STOPPING PROCEDURES.....	4
6.9	EMERGENCY STOPPING PROCEDURES.....	4
7.0	PACKAGING AND STORAGE	5
7.1	PACKAGING REQUIREMENTS.....	5
7.2	METHODS OF HANDLING.....	5
7.3	STORAGE.....	5
7.4	STORAGE SPACE AND HANDLING FACILITIES.....	5
8.0	TRANSPORTATION	5
8.1	HANDLING POINTS.....	5
8.2	WEIGHT.....	5
9.0	TROUBLESHOOTING GUIDE	5
10.0	MAINTENANCE	5
10.1	DESCRIPTION OF EQUIPMENT.....	5
10.2	ENGINEERING DRAWINGS AND PARTS LIST.....	5
10.3	RECOMMENDED SPARE PARTS.....	5
10.4	INSPECTION POINTS.....	5
10.5	SCHEDULED MAINTENANCE.....	6
10.5.1	Calibration Performed By End User.....	6
10.6	TECHNICAL SPECIFICATIONS.....	6

10.7	MAINTENANCE PERSONNEL REQUIREMENTS	6
11.0	PROVISION OF SPARES	6
11.1	SOURCE OF SPARE PARTS	6
11.2	RECOMMENDED SPARE PARTS LISTS	6
12.0	IN-SERVICE SUPPORT	6
13.0	GUARANTEES/LIMITATION OF LIABILITY	7
14.0	APPENDICES.....	7

This product can not be modified without the written approval of Tronair, Inc. Any modifications done without written approval voids all warranties and releases Tronair, Inc., its suppliers, distributors, employees, or financial institutions from any liability from consequences that may occur. Only Tronair OEM replacement parts shall be used.

TRONAIR OFFERS A COMPLETE RAM AIR TURBINE TEST SYSTEM WHICH CONSISTS OF:

- Ground Test Tool AGE17078
- GTT Pressure Monitoring Box AGE18380
- Hydraulic Power Unit 5933 or 5L33 series

1.0 PRODUCT INFORMATION

1.1 DESCRIPTION

Ground Test Tool for AIRBUS A380
Model AGE17078

1.2 MODEL & SERIAL NUMBER

Reference nameplate on unit

1.3 MANUFACTURER

TRONAIR , Inc. 1 Air Cargo Pkwy East Swanton, Ohio 43558 USA	Telephone: (419) 866-6301 or 800-426-6301 Fax: (419) 867-0634 E-mail: sales@tronair.com Website: www.tronair.com
---	---

1.4 FUNCTION

The Ground Test Tool (GTT), powered by a suitable hydraulic cart, is used to back drive the Ram Air Turbine (RAT) on the A380 aircraft during ground check out. The ground tests are to be performed in accordance with the airframe and RAT manufacturer's instructions.

This Ground Test Tool is to be operated only by qualified trained technicians.

This Operation and Service Manual is to be used only by qualified trained technicians.

1.5 LIST OF DRAWINGS

Outline Dimensions

1.6 RELEVANT STANDARDS

1. The GTT has been designed to comply with the following directives
 - 89/392/EEC: Machinery Directive
2. The following standards were used as guides to design the GTT
 - EN 292-1:1991
 - EN 292-2:1991/1995
 - BS EN 982:1996
 - prEC 1915-1:1995

1.7 OVERVIEW

The GTT is composed of a hydraulic motor, and adaptor plate, a splined adaptor shaft, two hoses approximately 20 ft (6.1 m) long with couplings for connection to a hydraulic cart, a strap and hook assembly for supporting the hose by the fuselage, and a storage case.

1.8 MATING COUPLINGS AND PLUGS

Couplings: Inlet Tronair # N-2794
 Outlet Tronair # N-2795
Coupling Assembly KHC-4010

2.0 SAFETY INFORMATION**2.1 USAGE AND SAFETY INFORMATION**

To insure safe operations please read the following statements and understand their meaning. Also refer to your equipment manufacturer's manual for other important safety information. This manual contains safety precautions which are explained below. Please read carefully.



WARNING! — Warning is used to indicate the presence of a hazard that **can cause severe personal injury, death, or substantial property damage** if the warning notice is ignored.

CAUTION! — Caution is used to indicate the presence of a hazard that **will or can cause minor personal injury or property damage** if the caution notice is ignored.

2.2 EXPLANATION OF WARNING AND DANGER SIGNS

- Misuse of machine can cause personal injury and/or property damage.
- Operation of the GTT must be in accordance with this manual, and the Airframe/RAT Manufacturer's Instructions

2.3 COMPONENT SAFETY FEATURES

Pressure rating safety factors are in accordance with EN 982:1996.

2.4 FEATURES FOR OPERATOR SAFETY

No additional features are included for operator safety. Safeguards against hazards created during the ground checkout must be provided by others in accordance with the Airframe/RAT Manufacturer's Instructions, and all applicable regulations.

2.5 PERSONAL PROTECTIVE EQUIPMENT

- Operators must use personal protective equipment in accordance with their employer's requirements
- See airframe/RAT manufacturer's information on maximum sound levels during ground checkout

2.6 SAFETY GUIDELINES

Any uses other than those identified in Section 1.1 of this manual are prohibited

2.7 CONDITIONS FOR SAFE USE

- Temperature Range: -10° F thru +120° F (-23° C thru +49° C)
- Operate in accordance with airframe/RAT manufacturer's instructions

2.8 TECHNICAL EXPERTISE**2.8.1 Installation**

The installation of this tool is to be completed by qualified aircraft technicians. See Section 5 for installation information.

2.8.2 Operation

This tool is to be used by skilled and trained aircraft technicians in accordance with this manual, and the airframe/RAT manufacturer's instructions. See Section 7 for Operation Instructions.

2.8.3 Maintenance

This machine is to be maintained by qualified maintenance personnel. See Section 10 for maintenance information.

2.9 ADDITIONAL SAFETY INFORMATION

Safeguards in accordance with airframe/RAT manufacturer's instruction must be used.

**WARNING!**

- **ALWAYS follow the airframe/RAT manufacturer's instructions when testing the RAT.**
- **ALWAYS use applicable safety equipment required for RAT ground checkout tests.**

3.0 TRAINING

3.1 TRAINING REQUIREMENTS

- GTT operators MUST be properly trained in all aspects of aircraft RAT ground check out.
- It is the employer's responsibility to ensure that the operator is qualified to use this tool.
- This GTT Operation and Service Manual does not provide qualified training to perform aircraft RAT ground checkout tests.

3.2 TRAINING PROGRAMS, MANUALS, METHODS, SUPERVISORS, AND OPERATORS

- Tronair does not provide training materials beyond the scope of this manual.
- It is the employer's responsibility to provide any training requirements beyond the scope of this manual.

3.3 OPERATOR TRAINING

The operator training should provide the required training for safe operation of the RAT.

NOTE: Maintenance and Trouble Shooting are to be performed by a skilled and trained technician.

4.0 ASSEMBLY

The GTT is shipped assembled and ready for use.

5.0 INSTALLATION

5.1 INSTALLATION REQUIREMENTS

Hydraulic Cart requirements: 33 gpm @ 5,000 psi (125 lpm @ 345 bar)



WARNING!

Do not exceed 5000 psi (345 bars) rated supply pressure to motor.

5.2 PERSONNEL REQUIREMENTS (TECHNICAL EXPERTISE) FOR INSTALLATION

This tool is to be installed and used by qualified aircraft mechanics in accordance with this manual, and employer and airframe/RAT manufacturer instructions.

5.3 SPECIFICATIONS AND STANDARDS

Pressure Hose.....(-16) 1 in (25.4 mm)
 Return Hose(-24) 1-1/2 in (38.1 mm)
 Transducer Hose.....(-4) ¼ in (6.3 mm)
 Motor/Adaptor/Spline/Fitting Weight.....Approximately 55 lbs (25 kg)
 Hose Length.....Approximately 20 ft (6.1 m)
 FluidAviation Phosphate Ester, Type IV or Type V

5.4 REQUIRED MATERIALS FOR INSTALLATION

- 33 gpm @ 5,000 psi (125 lpm @ 345 bar) Hydraulic Cart
- Aviation Phosphate Ester hydraulic fluid, Type IV or Type V as required

5.5 INSTALLATION PROCEDURE

NOTE: See Section 7.5 Preparation Prior to First Use before attaching the GTT to the RAT.

1. Remove any protective covers on the RAT generator/GTT interface
2. Remove the GTT from the case by carefully un-coiling the hoses, and lift the motor out of the case
3. Hook the hose hanging bracket onto the RAT bay door opening

NOTE: The inner shaft does normally connect to the motor using the cotter pin. This is the normal way of using the RAT GTT.

4. Remove the inner shaft, insert and align the main drive shaft, bolt the motor to the RAT case
5. Once the motor is bolted to the RAT case the inner shaft can be carefully inserted. Slight blade rotation allows the inner shaft to align the cotter pin location, insert the cotter pin and fix in location of the inner shaft

NOTE: The inner shaft does not rotate during testing, it is used to test the anti-icing system.

6. Attach the GTT to the interface on the back of the RAT generator, with seal drain facing downward, while ensuring the splined shaft properly engages the mating female spline in the RAT generator shaft
7. Secure the GTT to the RAT by tightening the four (4) 5/16-24 fasteners to 86 lb-in (9.7 N-m)
8. Support the hoses attached to the motor by hanging them from the RAT bay opening
9. Connect the -16 pressure hose to the proper coupling on the hydraulic cart (supply)
10. Connect the -24 return hose to the proper coupling on the hydraulic cart (return to tank)

5.0 INSTALLATION *(continued)***5.6 INSPECTION AND TESTING PROCEDURE UPON INSTALLATION**

- Verify that the couplings are properly engaged
- Verify that all fasteners on the GTT are properly tightened
- Verify that all hydraulic connections are tight

6.0 OPERATION**6.1 OPERATING PARAMETERS**

- Ground checkout tests on A380 RAT
- Temperature Range: -10° F thru +120° F (-23° C thru +49° C)

6.2 NUMERICAL VALUES AND LIMITS**6.2.1 General**

- Maximum speed3,800 rpm
- Phosphate Ester fluid
- Fluid consumption33 gpm (125 lpm) @ 3,500 rpm (theoretical)
- Maximum Pressure5,000 psi (345 bar)

6.2.2 Dimensions

- Case42 in (1064 mm) length x 42 in (1064 mm) width x 12 in (305 mm) height
- Pressure Supply Hose.....(-16) 1 in (25.4 mm) x 20 ft (6.1 m) long
- Return Hose(-24)1-1/2 in (38.1 mm) x 20 ft (6.1 m) long
- Motor Assembly Weight55 lbs (25 kg)

6.3 FEATURES

- The hydraulic motor provides power and speed capabilities consistent with the requirements of the ground checkout procedures for the A380.
- The GTT tool provides custom designed adaptor plate and splined shaft developed in conjunction with Hamilton-Sundstrand specifically for the A380.
- The specially designed storage case can be used for shipping the tool.

6.4 PERSONAL PROTECTIVE EQUIPMENT

Personal protective equipment must be used in accordance with employer's instructions, and local and federal regulations.

6.5 CHECKS PRIOR TO START UP

- Verify that the couplings are properly engaged.
- Verify that all fasteners on the GTT are properly tightened.
- Verify that all hydraulic connections are tight.

6.6 START UP PROCEDURE

Ensure that steps in 6.5 have been completed.

CAUTION!

To prevent personal injury and/or damage to aircraft:

- **ALWAYS follow the airframe/RAT manufacturer's instructions when testing the RAT.**
- **ALWAYS use applicable safety equipment required for RAT ground checkout tests.**

6.7 OPERATING PROCEDURES**6.7.1 Basic Operation**

Use the hydraulic cart to power the GTT in accordance with the instruction provided with the cart, and the ground checkout procedures for the RAT provided by the airframe/RAT manufacturer.

6.8 STOPPING PROCEDURES

To stop the GTT, remove the supply of pressurized fluid to the motor.

6.9 EMERGENCY STOPPING PROCEDURES

Follow the emergency stopping procedures provided in the instructions for the hydraulic test cart, and the airframe/RAT ground checkout procedures.

7.0 PACKAGING AND STORAGE

7.1 PACKAGING REQUIREMENTS

This tool is provided with a storage case that is suitable for shipment

7.2 METHODS OF HANDLING

- The GTT case can be rolled freely by hand
- No provisions for lifting by overhead crane are provided
- No specific methods of handling are required

7.3 STORAGE

- The GTT is suitable for indoor storage. Protect the tool from moist environments

7.4 STORAGE SPACE AND HANDLING FACILITIES

- Minimum: 42 in (1064 mm) length x 42 in (1064 mm) width x 12 in (305 mm) height
- No specific handling facilities are required

8.0 TRANSPORTATION

8.1 HANDLING POINTS

Handles are provided on three sides of the case for lifting and pulling

8.2 WEIGHT

200 lbs (90.7 kg)

9.0 TROUBLESHOOTING GUIDE

PROBLEM	PROBABLE CAUSE	REMEDY
GTT does not turn the turbine assembly	Turbine lock on	Unlock RAT turbine
	Low supply pressure	Ensure hydraulic cart is operating correctly
	No flow to motor	Open valves on hydraulic cart
	GTT improperly mounted	Correct mounting of GTT
	Turbine cannot be turned	Repair RAT turbine

10.0 MAINTENANCE

10.1 DESCRIPTION OF EQUIPMENT

- Hydraulic Motor Rebuild services provided by Tronair, Inc.
- Pressure Transducer Calibration services available by Tronair, Inc.
Reference Appendix IV Calibration Verification Procedures

10.2 ENGINEERING DRAWINGS AND PARTS LIST

Reference Illustrations and Table on following pages.

10.3 RECOMMENDED SPARE PARTS

Part Number	Description	Qty
TF-1117-36*240	Hose - 16	1
TF-1117-23*240	Hose - 24	1
TF-1041-05*09.9	Hose - 4	2
HC-2514	Shaft, Deicing (Inner)	1

10.4 INSPECTION POINTS

- Inspect splined shaft for wear
- Inspect hose connections for leaks

10.0 MAINTENANCE *(continued)*

10.5 SCHEDULED MAINTENANCE

All transducers on RAT Ground Test Tools can be either returned to Tronair for calibration or certified by the end user if proper calibration equipment is available. Transducers returned to Tronair for calibration will be tested with standards traceable to N.I.S.T. (National Institute of Standards and Technology). Tronair recommends calibration of instrumentation at yearly intervals, but actual calibration dates may be based upon frequency of use and the end users quality system. For information on returning gauges for calibration contact Tronair.

TRONAIR, Inc.
1 Air Cargo Pkwy East
Swanton, Ohio 43558 USA

Telephone: (419) 866-6301 or 800-426-6301
Fax: (419) 867-0634
E-mail: sales@tronair.com
Website: www.tronair.com

10.5.1 Calibration Performed By End User

- Calibrate Pressure Transducers, EC-1851 and EC-1852, at yearly intervals, but actual calibration dates may be based upon frequency of use and the end users quality system
- Ref: ASTM D5720-95 (2009) standard for details on calibration
- Reference Appendix III Installation Data Manual Pressure Transmitter for instructions
- Reference Appendix IV Calibration of Pressure Transducers

10.6 TECHNICAL SPECIFICATIONS

- Maximum speed3,800 rpm
- FluidAviation Phosphate Ester Fluid, Type IV
- Fluid consumption33 gpm (125lpm) @ 3,500 rpm (theoretical)

10.7 MAINTENANCE PERSONNEL REQUIREMENTS

Maintenance personnel should have a basic knowledge of hydraulic systems.

11.0 PROVISION OF SPARES

11.1 SOURCE OF SPARE PARTS

Spare parts may be obtained from the manufacturer:

TRONAIR, Inc.
1 Air Cargo Pkwy East
Swanton, Ohio 43558 USA

Telephone: (419) 866-6301 or 800-426-6301
Fax: (419) 867-0634
E-mail: sales@tronair.com
Website: www.tronair.com

For Spare Parts, Operations & Service Manuals or Service Needs:
Scan the QR code or visit Tronair.com/aftermarket



11.2 RECOMMENDED SPARE PARTS LISTS

Reference the following page(s) for Replacement Parts and Kits available.

12.0 IN-SERVICE SUPPORT

Contact Tronair, Inc. for technical services and information. See Section 1.3 – Manufacturer.

13.0 GUARANTEES/LIMITATION OF LIABILITY

Tronair products are warranted to be free of manufacturing or material defects for a period of one year after shipment to the original customer. This is solely limited to the repair or replacement of defective components. This warranty does not cover the following items:

- a) Parts required for normal maintenance
- b) Parts covered by a component manufacturers warranty
- c) Replacement parts have a 90-day warranty from date of shipment

If you have a problem that may require service, contact Tronair immediately. Do not attempt to repair or disassemble a product without first contacting Tronair, any action may affect warranty coverage. When you contact Tronair be prepared to provide the following information:

- a) Product Model Number
- b) Product Serial Number
- c) Description of the problem

If warranty coverage is approved, either replacement parts will be sent or the product will have to be returned to Tronair for repairs. If the product is to be returned, a Return Material Authorization (RMA) number will be issued for reference purposes on any shipping documents. Failure to obtain a RMA in advance of returning an item will result in a service fee. A decision on the extent of warranty coverage on returned products is reserved pending inspection at Tronair. Any shipments to Tronair must be shipped freight prepaid. Freight costs on shipments to customers will be paid by Tronair on any warranty claims only. Any unauthorized modification of the Tronair products or use of the Tronair products in violation of cautions and warnings in any manual (including updates) or safety bulletins published or delivered by Tronair will immediately void any warranty, express or implied.

The obligations of Tronair expressly stated herein are in lieu of all other warranties or conditions expressed or implied. **Any unauthorized modification of the Tronair products or use of the Tronair products in violations of cautions and warnings in any manual (including updates) or safety bulletins published or delivered by Tronair will immediately void any warranty, express or implied and Tronair disclaims any and all liability for injury (WITHOUT LIMITATION and including DEATH), loss or damage arising from or relating to such misuse.**

14.0 APPENDICES

- APPENDIX I Declaration of Conformity
- APPENDIX II Certification of Calibration Pressure Transducers
- APPENDIX III Installation Data Manual Pressure Transmitter
- APPENDIX IV Calibration of Pressure Transducers

Parts List

When ordering Replacement Part/Kits, please specify Model & Serial Number of your product.

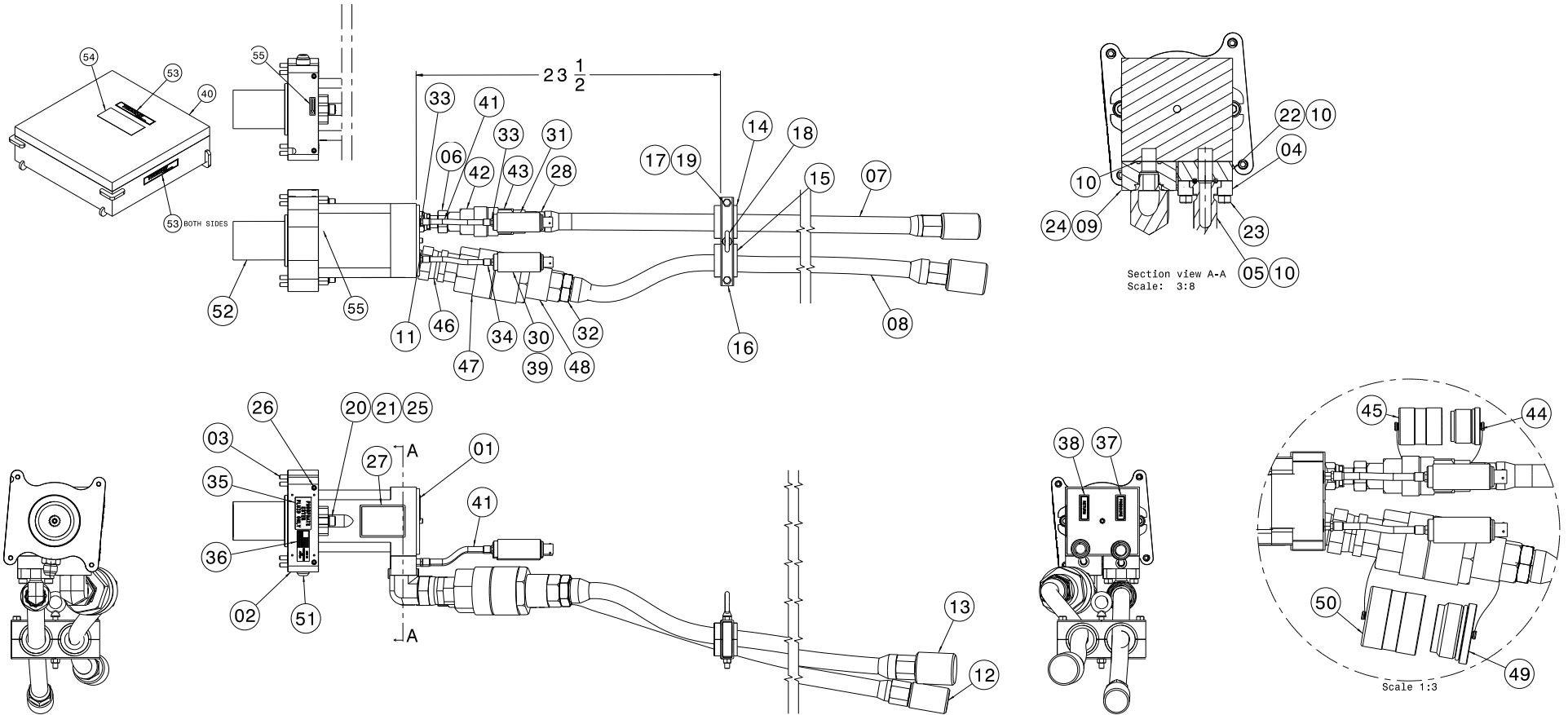

Parts List

When ordering replacement parts/kits, please specify model, serial number and color of your unit.

Item	Part Number	Description	Qty
1	HC-2224-01	Motor, Hydraulic	1
2	J-3532	Plate, Adapt A380 Prod	1
3	G-1478-106114	Screw, 5/16 – 24 Hex Socket Head Cap	4
4	N-2723-12-S-E	Kit, Metric Flange (Code 62)	1
5	N-2833-01-S-E	Connector, Code 62	1
6	N-2650-08-S-E	Connector, ORFS Swivel	1
7	TF-1117-36-240	Assembly, Hose PE (Pressure)	1
8	TF-1117-23-240	Assembly, Hose PE (Return)	1
9	J-3538	Flange, STR THD In-Line	1
10	HC-2006-214	O-Ring (PE)	3
11	N-2001-38-S-E	Elbow, ST THD x 37JIC	1
12	N-2792	Coupling, Nipple & Cap (Pressure)	1
13	N-2793	Coupling, Nipple & Cap (Return)	1
14	HC-2186-09	Bushing, Split-Multi-Clamp	1
15	HC-2186-11	Bushing, Split-Multi-Clamp	1
16	HC-2185-01	Clamp, Multi-Clamp	1
17	HC-2187-03	Nut, Stacking	3
18	G-1330-03	Eyebolt, 3/8 – 16 THD Shoulder	1
19	G-1100-107010	Bolt, HH, GR 5, 3/8 – 16 x 1 long	5
20	G-1255-09	Washer, ½ AN	2
21	G-1661	Bolt, Steel NAS1352, ½ - 13 x 2 Long	2
22	J-3556	Adaptor, Gauge Port	1
23	G-1491-108030	Screw, Socket Head Cap M10 – 1.5 x 60 Long	4
24	G-1491-108016	Screw, Socket Head Cap M10 – 1.5 x 35 Long	4
25	H-1608*24.0	Wire, Safety .032 inch Stainless	1
26	G-1478-103004	SCR, #10 – 24 HEX SOC HD Cap	4
27	V-2533	Label, Identification	1
28	N-2942-S-E	Fitting, Straight Thread	1
30	EC-1851	Transducer, Pressure	1
31	EC-1852	Transducer, Pressure	1
32	N-2007-31-S-E	Connector, Straight Thread	1
33	N-2007-03-S-E	Connector, Straight Thread	3
34	N-2007-06-S-E	Connector, Straight Thread	1
35	V-1977	Label, PE Fluid only	1
36	V-1001	Label, Made in USA	1
37	V-1894	Label, Pressure	1
38	V-1895	Label, Return	1
39	H-1513	Tie Wrap (<i>not shown</i>)	2
40	H-3768	Case, RAT Shipping	1
41	TF-1041-05*09.9	Assembly, Hose (#4)	2
42	N-2940-08	Quick Disconnect, Male #16 EPR	1
43	N-2940-07	Quick Disconnect, Female #16 EPR	1

Parts List

When ordering replacement parts/kits, please specify model, serial number and color of your unit.

Item	Part Number	Description	Qty
44	N-2941-05	Cap, Female 1"	1
45	N-2941-13	Cap, Male 1"	1
46	N-2036-13-S-E	Swivel, 37° Female	1
47	N-2940-12	Quick Disconnect, Male #24 EPR	1
48	N-2940-11	Quick Disconnect, Female #24 EPR	1
49	N-2941-07	Cap, Female 1.5"	1
50	N-2941-15	Cap, Male 1.5"	1
51	N-2007-18-S-E	Connector, Straight Thread	1
52	TR-1884	Shield, Protective	1
53	V-1033	Label, Tronair	3
54	V-2524	Label, AGE17078	1
55	V-2535	Label, Directional Arrow	1



APPENDIX I

Declaration of Conformity



EU Declaration of Conformity

Model Number(s) AGE17078
Product Type/Name: Ground Test Tool - Airbus A380 Ram Air Turbine
Serial Number(s): Enter serial number(s)

Declaration: Tronair has assessed the equipment described above against the Essential Health and Safety Requirements of one or more Directives. Based on this assessment, the equipment described above is deemed to comply with the directive(s) listed below.

This declaration of conformity is issued under the sole responsibility of the manufacturer.

Directives: European Machinery Directive 2006/42/EC

Standards: ARP 1247D Aircraft ground support equipment – General design requirements
 EN 1915-1:2013 Aircraft ground support equipment – General requirements – Part 1: Basic safety requirements
 EN ISO 4413:2010 Hydraulic Fluid Power – General rules and safety requirements for systems and their components

Markings: 

The technical documentation for the machinery is available from:

Mr. Joel Nunn
 34 Epirus Road, SW6 7UH, London, UK
 Email: jnunn@tronair.com

Location of Issue: Tronair, 1 Air Cargo Parkway East, Swanton, OH 43558

Certificate: EU_DoC_ AGE17078

Identification of person empowered to sign on behalf of the Manufacturer:

 Quality Assurance Representative

Enter a date
 Date





APPENDIX II

Certification of Calibration Pressure Transducer (two)



APPENDIX III

Installation Data Manual Pressure Transmitter



INSTALLATION DATA MANUAL
MODEL 249/349
PRESSURE TRANSMITTER

3829 Forest Parkway, Suite 500
Wheatfield, NY 14120
Int'l: 1-716-629-3800
Toll Free: 1-800-688-0030
Fax: 1-716-693-9162
www.viatran.com

solutions@viatran.com

PRODUCT OVERVIEW

All information contained in this document is representative of a standard Model 249/349. If the product you ordered has special requirements or modifications, refer to the Laser Marked information on the product and your purchase order for possible alteration to the product's configuration. Failure to verify product configuration before installation may cause permanent product damage and in most cases, void the manufacturer's product warranty. If you are unsure or have questions about your product, please contact our Application Engineers for assistance.

Remove and retain all instruction manuals and performance certificates that are shipped with the product. These documents provide important information on the product's calibration, operation, safety precautions, recommended maintenance, re-calibration requirements, repair service instructions and warranty information. These documents are updated from time to time as changes to the product occur and should be reviewed at receipt so that proper and safe installation can occur.

GENERAL REQUIREMENTS & CAUTIONS

1. All electrical & pressure connections should be compatible with the model specifications as outlined below.
2. Installation should occur only after electrical (input power) and line pressure is verified as being off and at zero.
3. The Model 249 and 349 products with a pressure range of 150 PSI and below are susceptible to sensor damage by being dropped, struck, or installed in a high vibration environment. These lower ranges employ an oil-filled silicon chip technology and can become damaged if handled or installed improperly. At no time should an object be inserted into the pressure port to deflect the sensor (to test or simulate pressure) as permanent fill loss and damage to the sensing diaphragm may occur.
4. The product's internal electrical circuitry is isolated from case ground. It is not recommended that the case or ground of the unit be connected to the input, output or calibrate pins of the product or wiring system. Ground loops and line noise will affect the product's performance and will in most cases cause internal electrical failure.
5. All products should be protected from direct or continued exposure to fluids at the electrical connection. It is recommended that for products installed in areas where the potential for contamination at the electrical connection is possible a "boot" or other protective measure be taken to eliminate possible deterioration of the product's electrical connection and corrosion that will impede product performance.
6. In severe environments, we suggest the zero and span adjustment screws be protected from possible buildup of media or corrosion. A small piece of electrical tape can be used to cover the screw. If buildup or corrosion occurs, adjustment may be prevented due to the screw "slot" being filled in.
7. On some lower range models a breather opening, with breather plug, is used to allow for proper product function. At no time should any mist, vapor or fluid be permitted to enter this breather as unit failure may occur.
8. When shipped in quantities, units should be packaged individually to eliminate possible damage.

BASIC OPERATION

The Models 249 and 349 have external adjustments which allow the user to fine tune the zero reading by use of a potentiometer. They also have adjustment for span and an installed calibration circuit allowing for field calibration. Simple field calibration and reset of the zero and span readings can be achieved by accessing the adjustment screws. The adjustment screws are 10 turn potentiometers and only require slight turn to adjust. The potentiometers will provide a nominal adjustment of approximately $\pm 10\%$ of the Full Scale Output. In normal use, product calibration need only be checked upon initial installation and on an annual schedule thereafter.

INTERNAL CALIBRATION CIRCUIT

The Models 249 and 349 allow for field calibration or resetting of the product's output parameters. A factory installed calibration circuit has a value preset to a known pressure which, when activated, electrically simulates pressure. On the "49" Series, this value is 80% FSO $\pm 5\%$. The actual equivalent calibration pressure reading is laser marked on the exterior of the product and is listed on the performance certificate. To activate the calibration circuit, it is necessary to connect (short) the two calibration pins listed on the product (and/or) this manual. Note: When using multiple transmitters, cal circuits must be separated, not tied to a common pole.

Use of the circuit is explained below:

1. With power on and the unit at Zero (0) PSIG (for gage and vacuum) or Absolute Zero (full vacuum) for absolute models, adjust the zero pot on the signal conditioner to read the value as noted for zero on the performance certificate. If the certificate is unavailable then adjust zero for 0.000 volts on 0-5 VDC or 4.00 mA on 4-20 mA units. **Note: If the product you are calibrating has a special calibration or range, you may have to contact Viatran for a replacement performance certificate so that the actual settings of zero and span are known. A nominal fee will be charged for regeneration of the product's performance certificate.**
2. After completing zero adjustment (and with no increase in pressure applied to the sensor) activate the calibration circuit as listed on the installation data sheet included with this manual. The output should now rise to a reading equivalent to the specified reading on the performance certificate or on the unit's label. If the certificate is not available, the calibration output can also be calculated by using the following formula:
Voltage Output Products: Cal. Output = (Cal. Pressure from label / Pressure Range) x (*FSO)
Current Output Products: Cal. Output = ((Cal. Pressure from label / Pressure Range) x 16) + 4
*Where FSO represents the "Full Scale Output", a 0 to 5 volt unit = 5, a 1 to 5 volt unit = 4, etc.
3. To adjust the calibration reading as needed, use the "Span" adjustment to correct or, if none is needed, simply deactivate the calibration circuit and the unit will return to the "normal" operation mode.
4. If during this process it is determined that the product cannot be adjusted to the required calibration value or, if after adjustment, the product's performance is still in question, contact the factory for assistance.
5. Check the zero reading which may have changed due to interaction with the span adjustment. Steps 1-5 may need to be repeated.

Note: The calibration circuit must be deactivated in order for the product to perform properly.

INSTALLATION DATA - VIATRAN MODEL 249/349

Note: The drawing below is for informational purposes only and is not to scale.

All dimensions are nominal, in inches and for reference purposes only.

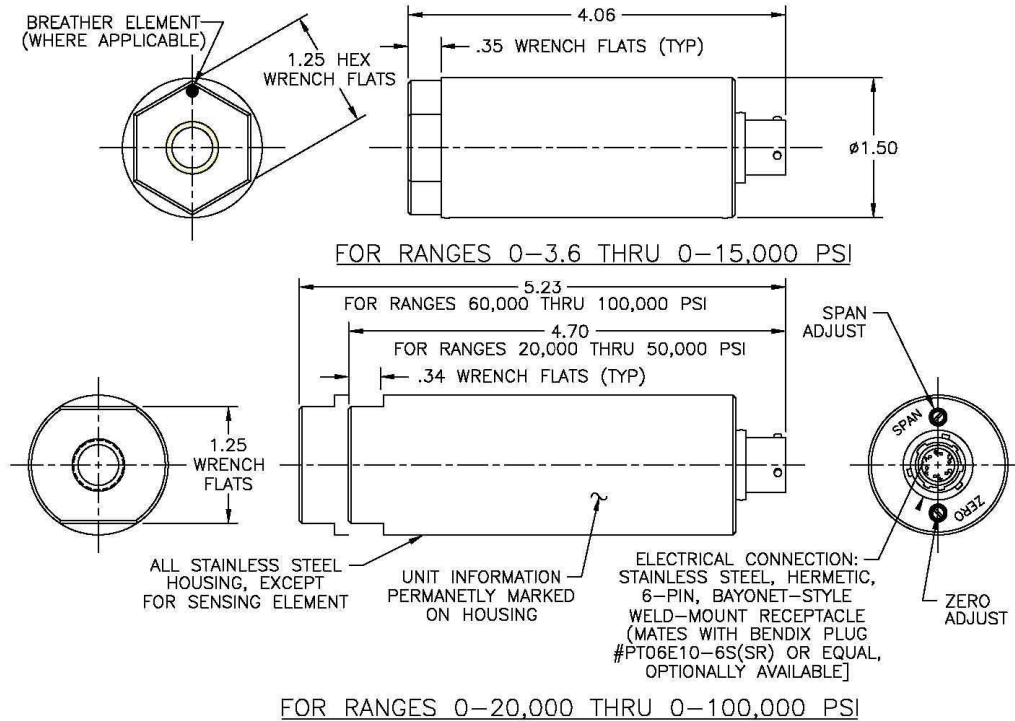

MODEL 249	MODEL 349	Sensor Construction and Wetted Materials:
Input:	Input:	3.6 - 150 PSI: Oil Filled - Silicon - 316 SST and Viton O-Ring
9 - 40 VDC	9 - 40 VDC	200 - 15K PSI: Bonded Foil Strain Gage - 15-5 PH SST
Output:	Output:	20K - 100K PSI: Tube Design - 13-8 Mo PH SST
0 - 5 VDC	4 - 20 mA	Pressure Connection:
Cal Shunt:	Cal Shunt:	3.6 - 15K PSI: 1/4" NPT female
80% FSPR	80% FSPR	20K - 50K PSI: AE TYPE F-250-C
		60K - 100K PSI: AE TYPE F-312-C150

CONNECTION DIAGRAMS & WIRING

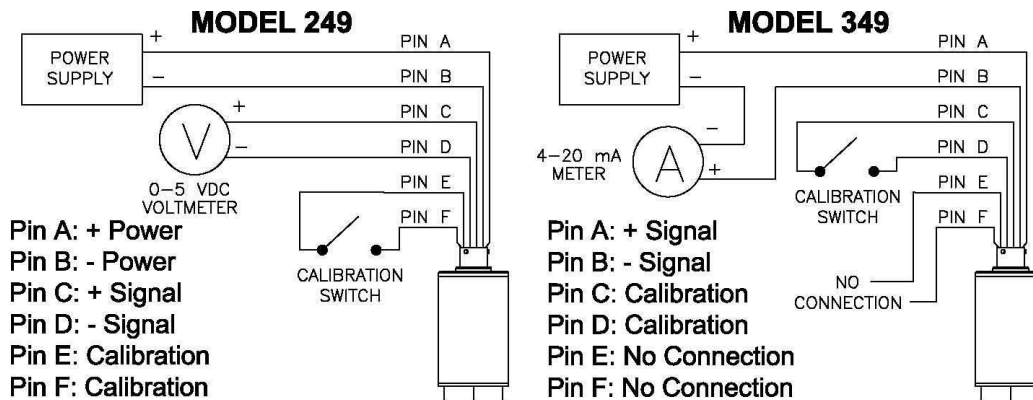

ACCESSORIES – OPTIONAL EQUIPMENT

Please contact Viatran for these and other available accessories.

Mating Connectors
Mating Cable Assembly
Mounting Bracket
Protective Cover
Digital Meter

MAINTENANCE AND REPAIR

All Viatran transmitters have been designed to function free from routine or scheduled maintenance. Simple cleaning of the electrical connector, pressure port threads and pressure cavity on an as needed basis will provide many years of satisfactory performance. Protecting the product from continued exposure to moisture or fluids at the electrical connection, breather area (model dependent) will eliminate premature internal failure of the product. Generally any time the product is removed from service the connector and pressure port threads should be cleaned and the pressure cavity flushed with a cleaner compatible to the specified wetted parts to prevent media buildup. During the cleaning process only a soft, lint-free cloth is recommended. Never use a coarse or stiff bristle brush to clean media from the diaphragm surface.

It is suggested that the calibration be verified on a usage dependent schedule. If the product is in continuous service 7 days a week, then calibration verification may be necessary every 6 to 8 months. If the product is in a lab test environment a more lenient verification schedule would be appropriate. In all instances the performance of the product will depend on the individual application or process in which it is installed. More continued usage would require a shorter period between calibration verification and product maintenance.

If a product is perceived to be exhibiting problems, it can be returned to Viatran for analysis and/or repair. It is suggested that only Viatran personnel attempt repair of the product. Any damage resulting from customer disassembly would result in a loss of coverage under the warranty policy. All Viatran products are able to be repaired at minimal cost if simple cleaning and precautions are taken in the handling and application of the product. Older products returned for repair are updated to current specifications unless the repair cost would outweigh the cost of a new replacement model. Products returned for repair should include information on the person to contact for repair quote approval, the individual to contact if Viatran's technical staff requires additional information during analysis, and a brief description of the problem associated with the product's failure.

WARRANTY

Viatran Corporation warrants that its products shall be free from defective workmanship and/or material for a period of twelve (12) months from the date of shipment, provided that Viatran's obligation hereunder shall be limited to correcting any defective workmanship and/or replacing any defective material f.o.b. factory. No allowance will be made for any expense incurred for correcting any defective workmanship and/or material without written consent by Viatran. This warranty is in lieu of all other warranties expressed or implied.

REPAIR INSTRUCTIONS

Viatran's Transmitters are designed to be easily repaired and recalibrated if necessary. If a failure occurs, the transmitter should be returned to the factory for inspection and testing. Please contact the Customer Support Department at 1-800-688-0030, for a return tracking number and/or a repair cost estimate. A nominal inspection fee is charged on all units returned to the factory which are not subsequently repaired.

3829 Forest Parkway, Suite 500
Wheatfield, NY 14120
Int'l: 1-716-629-3800
Toll Free: 1-800-688-0030
Fax: 1-716-693-9162
www.viatran.com
solutions@viatran.com



APPENDIX IV

Calibration of Pressure Transducers

CALIBRATION OF PRESSURE TRANSDUCERS

An accurate master pressure calibration gage and digital voltmeter is required for calibration of the Pressure Transducers.

PRESSURE SYSTEM PRESSURE TRANSDUCER (EC-1852)

Date: _____ Serial Number: _____

Excitation Power: 24 VDC Full Scale Pressure: 0 - 5K psig Output: 0 – 5 VDC
 Wiring Connections: Pin A +POWER
 Pin B -POWER
 Pin C +SIGNAL
 Pin D -SIGNAL

Applied Pressure (Master Pressure Gage) (psig)	Minimum Acceptable (volt DC)	Maximum Acceptable (volt DC)	Pressure Movement (Direction)	Indicated Transducer Reading (volt DC)
0	-0.005	0.005	-	
1000	0.995	1.005	Increasing	
2000	1.995	2.005	Increasing	
3000	2.995	3.005	Increasing	
4000	3.995	4.005	Increasing	
5000	4.995	5.005	Increasing	
4000	3.995	4.005	Decreasing	
3000	2.995	3.005	Decreasing	
2000	1.995	2.005	Decreasing	
1000	0.995	1.005	Decreasing	
0	-0.005	0.005	Decreasing	
Allowable operating tolerance: +/- 0.1% of full scale (5000 psig) at room temperature (70° F)				

PRESSURE SYSTEM PRESSURE TRANSDUCER (EC-1851)

Date: _____ Serial Number: _____

Excitation Power: 24 VDC Full Scale Pressure: 0 – 1.5K psig Output: 0 – 5 VDC
 Wiring Connections: Pin A +POWER
 Pin B -POWER
 Pin C +SIGNAL
 Pin D -SIGNAL

Applied Pressure (Master Pressure Gage) (psig)	Minimum Acceptable (volt DC)	Maximum Acceptable (volt DC)	Pressure Movement (Direction)	Indicated Transducer Reading (volt DC)
0	-0.005	0.005	-	
300	0.995	1.005	Increasing	
600	1.995	2.005	Increasing	
900	2.995	3.005	Increasing	
1200	3.995	4.005	Increasing	
1500	4.995	5.005	Increasing	
1200	3.995	4.005	Decreasing	
900	2.995	3.005	Decreasing	
600	1.995	2.005	Decreasing	
300	0.995	1.005	Decreasing	
0	-0.005	0.005	Decreasing	
Allowable operating tolerance: +/- 0.1% of full scale (1500 psig) at room temperature (70° F)				