

# LEKTRO

## Model **AP8750CX-AL** AIRCRAFT TOWING VEHICLE FOR AIRCRAFT UP TO 85,000 LBS/38,555 KG

1190 S.E. Flightline Drive, Warrenton, Oregon 97146-9692  
1-800-535-8767 • 503-861-2288 • Fax 503-861-2283  
E-mail: sales@lektro.com  
http://www.lektro.com

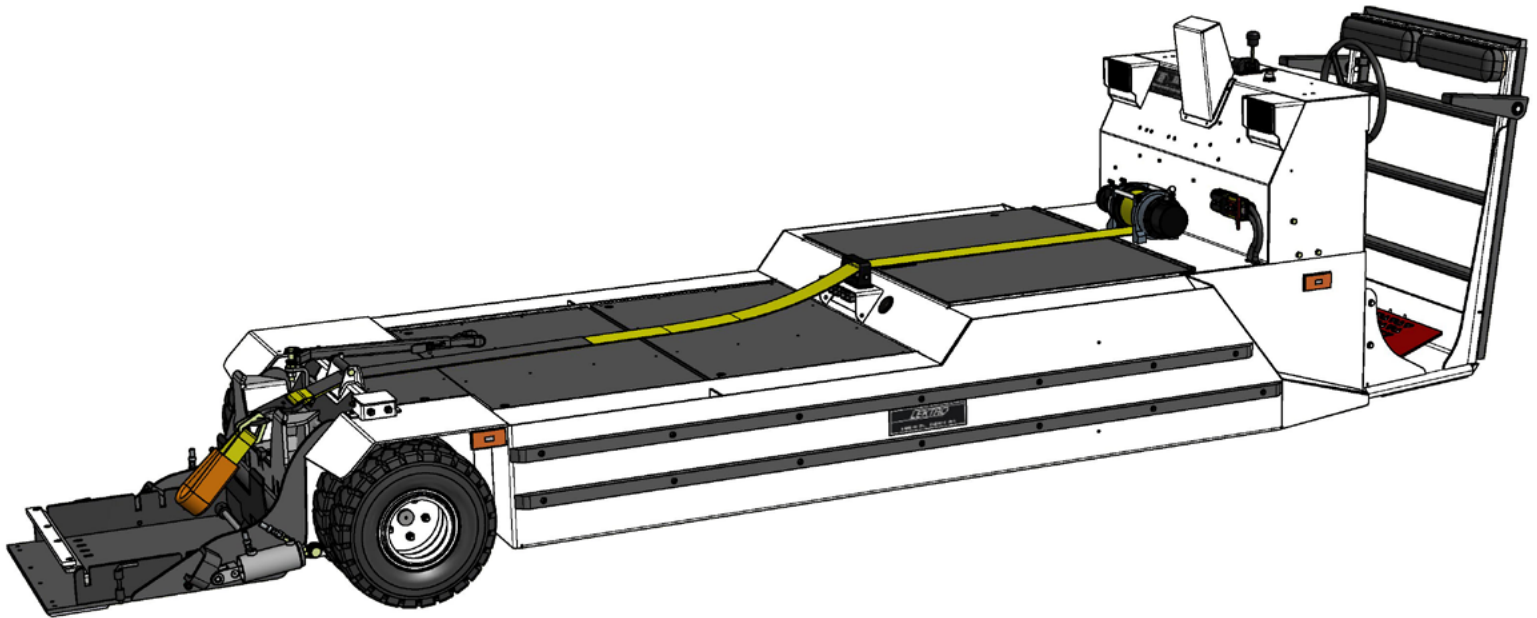

### AP8750CX-AL FEATURES:

**Vehicle Drive:** 33.1 HP/24.8 kW, 72 VDC Traction Motor mated with Auburn/Dana 44 Differential. Limited Slip Differential, optional.  
**Motor Speed Control:** EV100ZX SCR with On-Board Diagnostics. Speed controlled by combination Hand Throttle/Directional Lever.  
**Batteries:** 72 VDC Industrial, 275 AMP-HR Battery (6 hr rate), with Single Point Watering System. 375 AH, optional.  
**GPU:** Built-in Independent 12/24/28 VDC / 1175 CCA Batteries and Charging System, optional.  
**Motive Battery Charger:** External Fully Automatic 60 AMP DC / 208-480 VAC / 60 Hz / 1-PH Charger. 3-PH and/or 50 Hz, optional.  
**Nose Gear Lift Cradle:** Patented Universal Nose Gear Lift Cradle activated by an Electric/Hydraulic Pump Assembly capable of handling dual and single wheel aircraft, and a Hold Down provision for light-nosed aircraft. Wheel Faring Package, Aircraft Selection System and Patented Torque Sensing Turntable Cradle Deck, optional.  
**Winch:** Heavy-duty Hydraulic Winch with Automatic Safety Cut-Off. Winch and Strut Straps included.  
**Steering:** Automotive-type Wheel coupled to an Automotive Gear Box resulting in very responsive steering action.  
**Service Brakes:** Foot Operated Hydraulic Disc-Type Service Brakes at each Drive Wheel.  
**Parking Brake:** Hand/Foot activated Electric Deadman Parking Brake.  
**Drive Tires:** Dual 5.00 x 8 10-ply Poly-Foam Filled Pneumatic Traction Tread. Auto Socks and Chains, optional.  
**Steer Tires:** Dual 5.00 x 8 10-ply Poly-Foam Filled Pneumatic Traction Tread. Steer Axle Suspension, optional.  
**Lighting:** Dual Built-in Forward and Aft LED Headlights and Five Flashing Amber LED Running Lights.  
**Extension Ladder:** Step Ladder attached to operator's back rest.  
**Operator's Compartment:** Two person configuration, Stand-Up Operation with Restraint.

**Construction:** Welded Steel Plate and Polymers preserved by Primer and Automotive High-Gloss Red or White Enamel Paint with special protective Polyurethane Coating to prevent rust, scratches and corrosion. Steel Rub Rails protect from side impact. Custom colors, optional.

### SPECIFICATIONS:

Length.....	191.25 in / 485.6 cm
Width .....	56.75 in / 144.0 cm
Height (at top of steering wheel).....	50 in / 126.7 cm
Turning Radius .....	171 in / 434 cm
Wheel Base .....	113.25 in / 287.5 cm
Vehicle Speed, Empty .....	6 MPH / 9.6 KPH
Vehicle Speed, Loaded (To max. Vehicle Capacity)...	3.3 MPH / 5.4 KPH
**Lift Cradle Capacity .....	8500 LBS / 3855 KG
Nose Gear Cradle Lifting Height.....	9 in / 23 cm
Ground Clearance .....	5 in / 12.7 cm
Shipping Weight w/o Batteries & Charger .....	3440 LBS / 1560 KG
Shipping Weight w/ Motive Batteries & Charger...	5765 LBS / 2615 KG
Shipping Weight w/ Motive & GPU Batteries & Charger..	6115 LBS / 2774 KG

\*\*Lift Capacity is calculated with 18 in / 46 cm diameter aircraft tire in lift cradle. Aircraft tire center line at 20.5 / 52 cm from drive tire center line.

### ADDITIONAL OPTIONS:

Draw Bar Pin, Specialized Aircraft Towing Adapters and Custom Highlift Adapters are available (consult factory). Illustration may show some optional equipment.

\*LEKTRO reserves the right to make changes and improvements in products and specifications without notice or obligation.

PATENT Nos. 5,151,003 / 5,302,075 / 9,067,691.

Other Patents Pending.

# LEKTRO

## Model AP8750CX-AL

AIRCRAFT TOWING VEHICLE  
FOR AIRCRAFT UP TO 85,000 LBS/38,555 KG

1190 S.E. Flightline Drive, Warrenton, Oregon 97146-9692

1-800-535-8767 • 503-861-2288 • Fax 503-861-2283

E-mail: sales@lektro.com

http://www.lektro.com

