



Parts and Service Manual

Vehicle Types: eTT12

Introduction

From everyone at Eagle Tugs, we would like to say thank you for purchasing an Eagle eTT series tow tractor. We take a lot of pride in the quality of the products that we build, as well as, our continued customer service. Our goal is to build a long term relationship with our customers. We want you, the customer, to be 100% satisfied with your Eagle experience. To us, this means that your Eagle eTT series tractor is functionally superior to any other products you have used. This also means that your Eagle product is continually supported in a professional, timely manner.

Purpose and Use of This Manual

This manual is designed as a reference guide to make the reader more familiar with the components of the Eagle eTT series tow tractor models. This manual includes part numbers and descriptions to assist the reader in ordering component spare/service parts. The manual also outlines the Scheduled Maintenance Intervals recommended by Eagle in order to keep your vehicle running properly. For information pertaining to the safe operation of your Eagle product, please see the Eagle Operations Manual that was also included with your vehicle.

Technical Assistance

When addressing a repair procedure or operational problem, please remember that Eagle technical support is only a phone call away. Eagle technicians are available to assist you in vehicle diagnostics and recommended repair procedures. We encourage you to use this service to reduce machine down-time and to gain a better understanding of proper repair procedures.

Ordering Spare/Service Parts

Eagle inventories many of the spare/service parts found in its eTT series tow tractors, and most of these parts can be shipped the same day the order is received. Part orders need to be received at Eagle by 12:00 pm (Noon) EST in order for the parts to be shipped that same day. Parts ordered after 12:00 pm EST will usually be shipped the following day. Non-stock parts orders will be shipped as soon as the parts are available.

Contact Information

Corporate Offices
Sales, Support, Customer Service
Eagle Industrial Truck
26111 Northline Rd.
Taylor, MI 48180
USA
734.442.1000 — 800.671.0431

Website

Please check www.eagletugs.com periodically for updates to this manual, operations manual, and service bulletins that affect your tractor.

Email Addresses

Customer Service	customerservice@eagletugs.com
Parts Department	parts@eagletugs.com
Technical Support	support@eagletugs.com
Sales Department	sales@eagletugs.com

General Safety

Important Safety Notice

Appropriate service methods and proper repair procedures are essential for the safe and reliable operation of all industrial equipment as well as the personal safety of the individual performing the work. This service manual provides general directions for accomplishing service and repair work with tested and effective techniques. Following them will help assure reliability.

There are numerous variations in procedures, techniques, tools, and parts for servicing equipment, as well as in the skill of the individual doing the work. This manual cannot anticipate all such variations and provide advice or cautions as to each. Accordingly, anyone who departs from the instructions provided in this manual must first establish that he compromises his/her personal safety and/or the equipment integrity by his/her choice of methods, tools or parts.

General Warnings

The following list contains some general warnings that you should follow when you work on equipment:

- Always wear safety glasses for eye protection.
- Use safety stands whenever a procedure requires you to be under the equipment.
- Ensure that the traction battery is disconnected and that any capacitors are discharged (turn the tractor key on with the battery disconnected).
- Ensure that the hydraulic accumulator pressure has been bled by pumping the brakes and turning the front axle steering with the traction battery disconnected.
- Set the parking brake when working on the equipment. Place wheel chocks on the tires to provide further restraint from inadvertent equipment movement.
- Keep yourself and your clothing away from moving parts when the motor is running.
- Do not smoke while working on the equipment.
- To avoid injury, always remove rings, watches, loose hanging jewelry, and loose clothing before beginning to work on the equipment. Tie long hair securely behind the head.

For more information regarding safety please refer to the operations manual provided with your tug. This manual can also be found on the Eagle Tugs website at www.eagletugs.com.

This page intentionally left blank.

Table of Contents

Section	Contents
1 - Introduction	General Usage, Contact Information, Table of Contents
2 - Motor Assembly	Electric Motor, Transfer Case, Bearing Housings, Cradle Assembly
3 - Drivetrain	Axle Installation, Driveshafts, Wheels and Tires
4 - Electrical Subassemblies	Drive Inverters, Contactor Assembly, Dash Panel, Fuse Box
5 - Electrical System	Lighting, Harness Routing, Misc. Electrical Components
6 - Hydraulic Subassemblies	Pump Assembly, Manifold Assembly
7 - Hydraulic System	Schematic, Hydraulic Tank, Hoses, Accumulators, Hose Routing
8 - Op. Interface and Chassis	Seats, Steering Column, Access Panels, Louvers, Parking Brake
9 - Optional Equipment	Beacon, Dual Battery, Backup Alarm, Spotlights
10 - Specifications	Complete Vehicle Specifications
11 - Preventive Maintenance	Preventive Maintenance Schedule and Information
12 - Safe Handling	Flat and Raised Towing, Lift Points and Procedures
13 - Troubleshooting	Error Codes, Diagnostic Information
Appendix A - Controls	Logic System and Drive Information, 4WS
Appendix B - Battery Care	Battery Care and Maintenance
Appendix C - Axles	Axle Service Parts
Appendix D - Transfer Case	Transfer Case Service Parts
Appendix E - Electrical Schematics	Electrical Schematics

Revision Log

Rev	Date	Description	Appr.
A	20-Feb-2014	Original release for production	PRB
B	20-Jan-2015	Corrected appendix section letters	PRB
C	6-Jun-2016	Changed eXL16 model name to eTT16	TFP

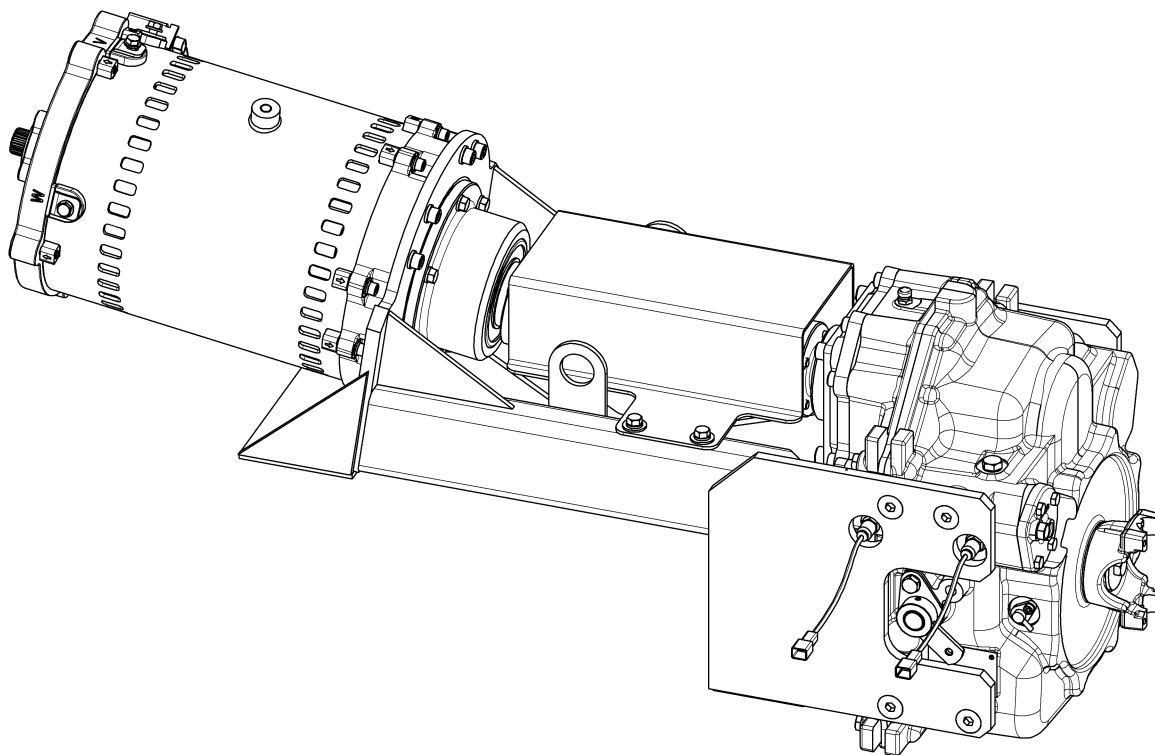

Section 2 - Motor Assembly

Description	Page
Motor Bearing Housing	2-2
Transfer Case Bearing Housing	2-3
Transfer Case to Bracket	2-4
Traction Motor to Bracket	2-6
Motor Driveshaft	2-7
Motor Driveshaft Subassembly	2-8
Cradle to Chassis	2-9
Revision Log	2-10

Motor Bearing Housing

This page applies to units S/N 12E112 and 8E108, 12E115, 16E103 and later units only.

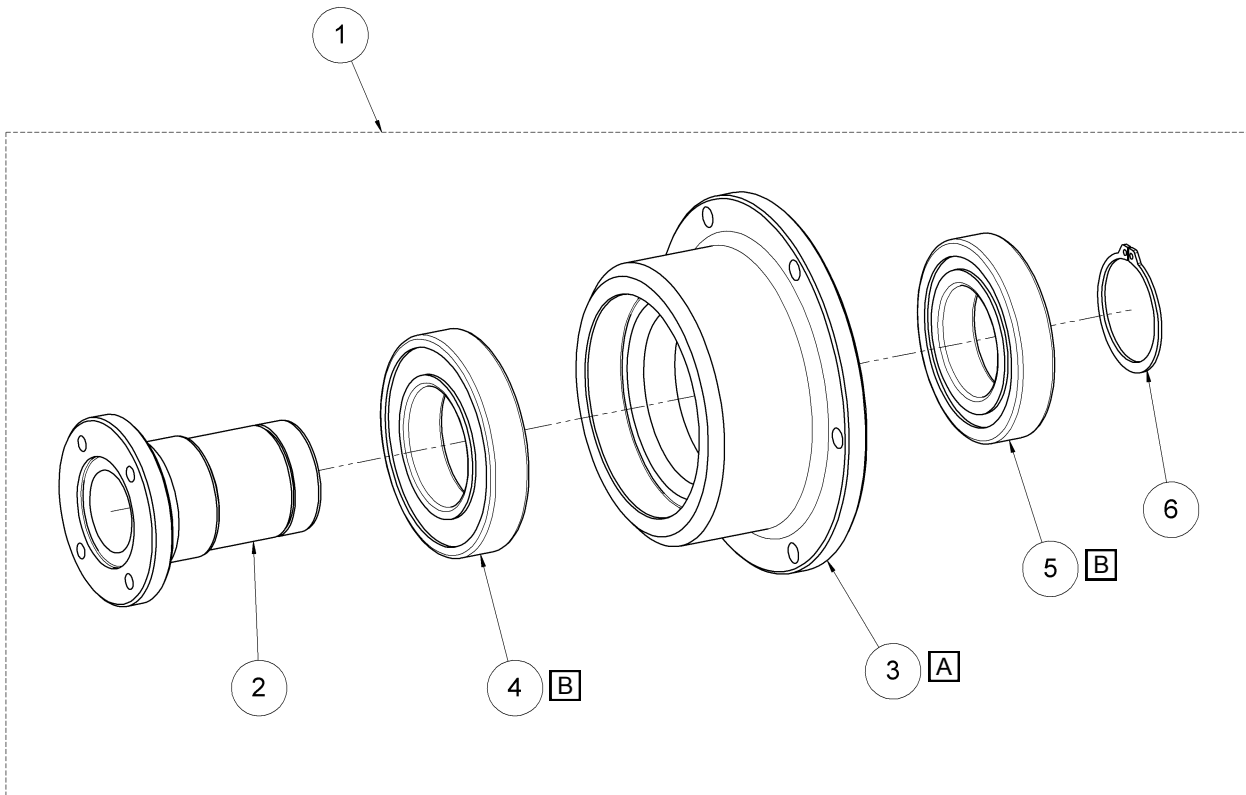

A Apply Loctite® 638™ retaining compound or comparable to bearing bores during install.

B Bearings must be installed using a bearing press.

Item	Part Number	Qty.	Description
1	ET00-04-007-KA	1	MOTOR BEARING HOUSING, COMPLETE
2	ET00-04-003-SA	1	MOTOR STUB SHAFT
3	ET00-04-004-SA	1	BEARING MOUNT PLATE, MOTOR
4	ET00-04-006-CA	1	SEALED BALL BEARING
5	A-ES12-0420-BEARING	1	SEALED BALL BEARING
6	A-ES12-0420-SNAPRING-2	1	SNAP RING

If your tractor falls outside of this serial number range, replacement parts are only available as a whole kit.

Transfer Case Bearing Housing

This page applies to units S/N 12E112 and 8E108, 12E115, 16E103 and later units only.

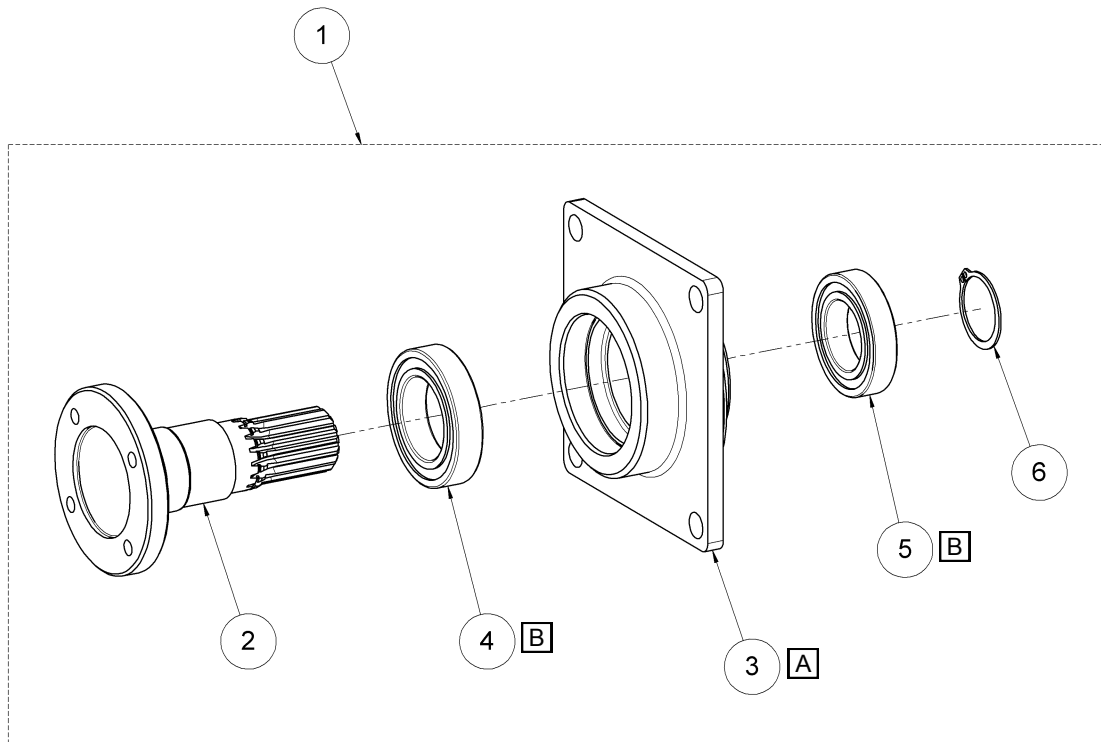

A Apply Loctite® 638™ retaining compound or comparable to bearing bores during install.

B Bearings must be installed using a bearing press.

Item	Part Number	Qty.	Description
1	ET00-04-008-KA	1	TRANSFER CASE HOUSING, COMPLETE
2	ET00-04-002-SA	1	TRANSFER CASE STUB SHAFT
3	ET00-04-001-SA	1	TRANSFER CASE SEAL PLATE
4	ET00-04-005-CA	1	SEALED BALL BEARING
5	A-ES12-0405	1	SEALED BALL BEARING
6	A-ES12-0421	1	SNAP RING

If your tractor falls outside of this serial number range, replacement parts are only available as a whole kit.

Transfer Case to Bracket

This page applies to units S/N 8E114, 12E126, 16E102 and earlier units only.

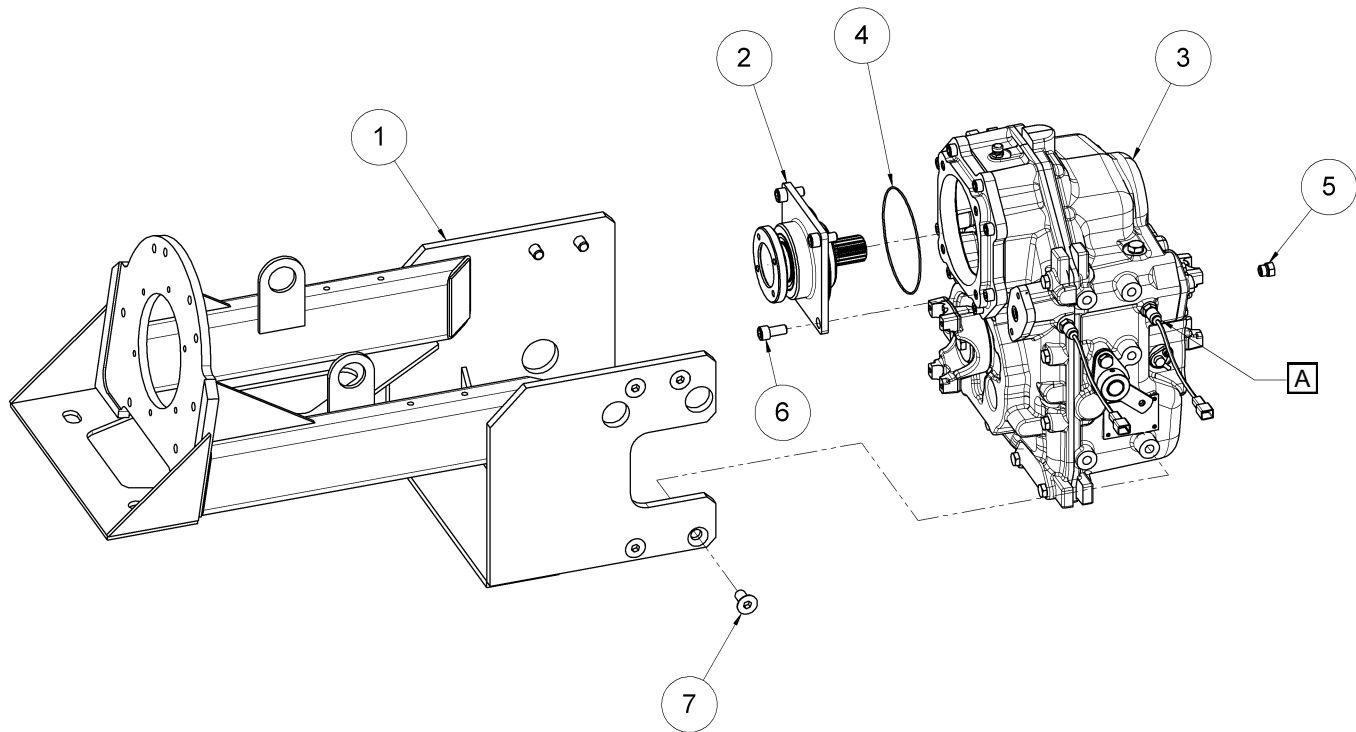

A Gear position sensors must be removed temporarily to install/remove item 3 to item 1.

Item	Part Number	Qty.	Description
1	A-ES12-0390	1	MOTOR AND TRANSFER CASE BRACKET
2	ET00-04-008-KA	1	TRANSFER CASE HOUSING, COMPLETE
3	A-ES12-0434	1	TWO-SPEED GEARBOX
4	A-ES12-028193	1	O-RING
5	7237X6	1	HEX PLUG, -6 SAE ORB
6	NPN	4	SHCS, M12X1.75 X 30
7	NPN	8	FHS, M14X2.0 X 30

Transfer Case to Bracket

This page applies to units S/N 8E115, 12E127, 16E103 and later units only.

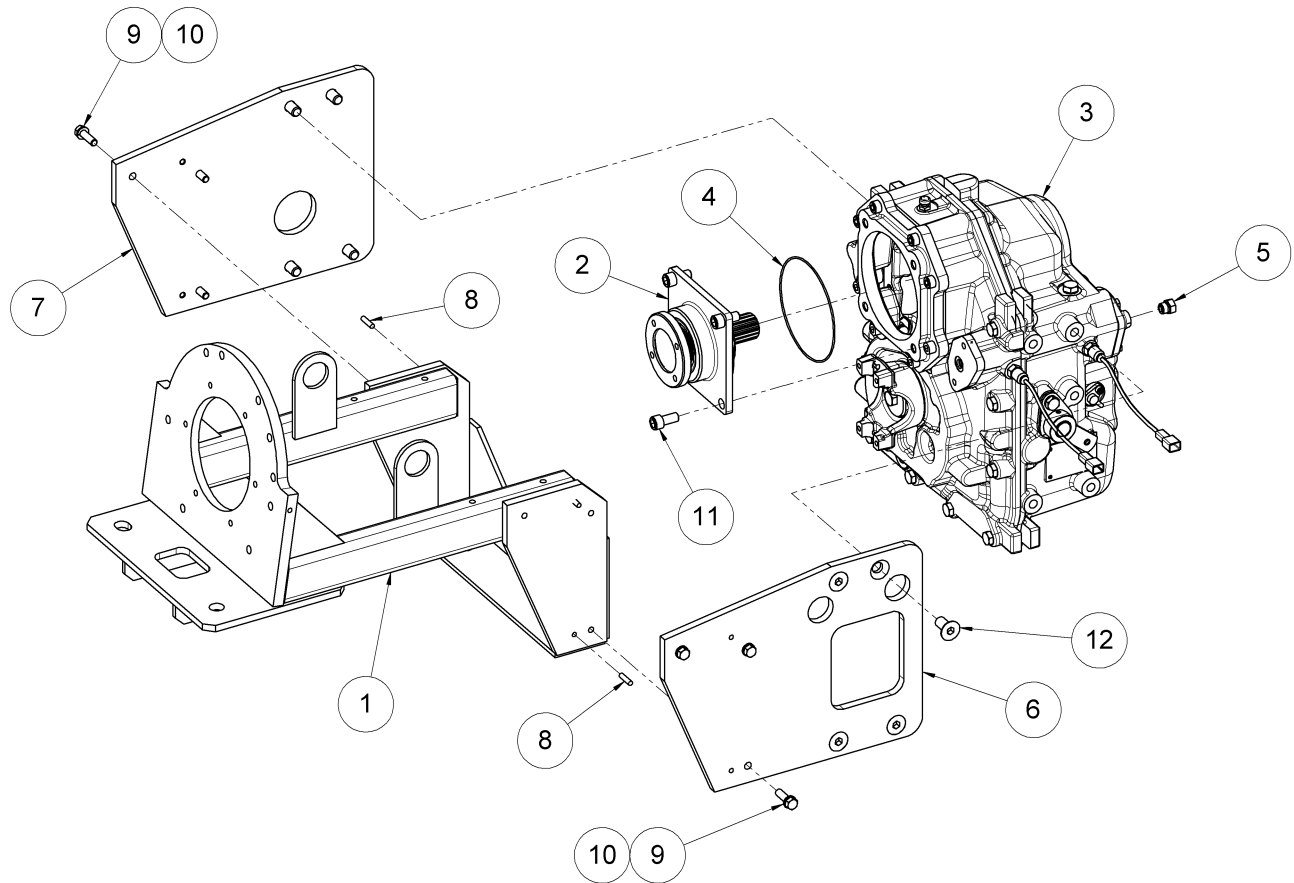

Item	Part Number	Qty.	Description
1	ET00-03-001-SA	1	MOTOR CRADLE WELDMENT
2	ET00-04-008-KA	1	TRANSFER CASE HOUSING, COMPLETE
3	A-ES12-0434	1	TWO-SPEED GEARBOX
4	A-ES12-028193	1	O-RING
5	7237X6	1	HEX PLUG, -6 SAE ORB
6	ET00-03-002-SA	1	RH TRANSFER CASE MOUNT
7	ET00-03-003-SA	1	LH TRANSFER CASE MOUNT
8	ET00-21-001-CA	4	DOWEL PIN, .25 X 1.0
9	NPN	6	HCS, 3/8-16 UNC X 1.0
10	NPN	6	LOCK WASHER, 3/8
11	NPN	4	SHCS, M12X1.75 X 30
12	NPN	8	FHCS, M14X2 X 30

Traction Motor to Bracket

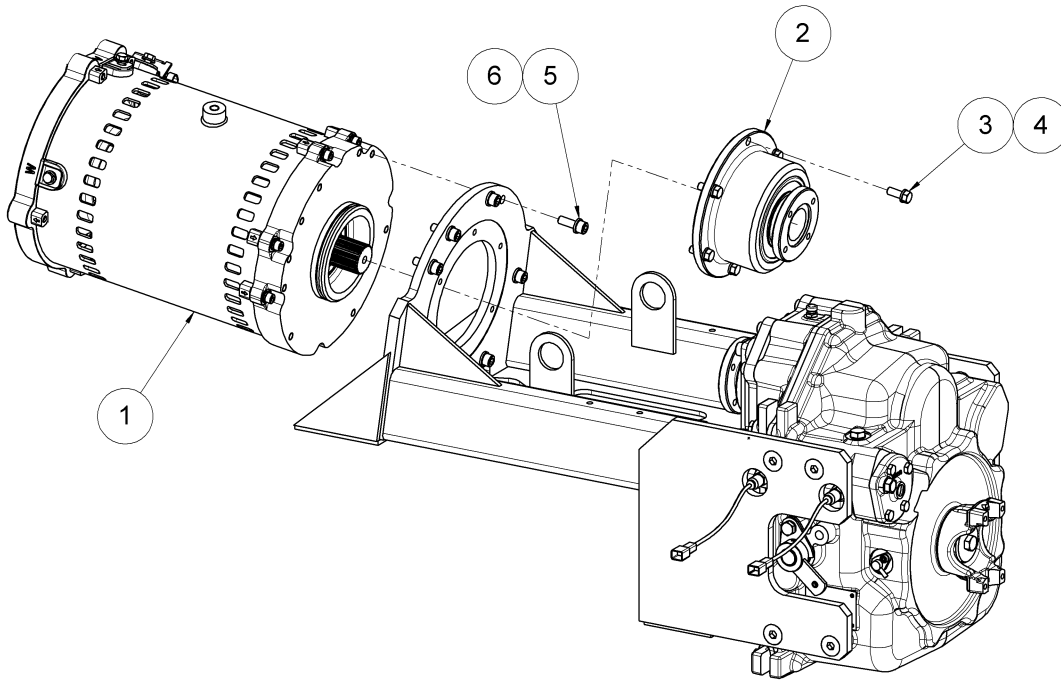

Item	Part Number	Qty.	Description
1	A-ES12-0420	1	TRACTION MOTOR
2	ET00-04-007-KA	1	MOTOR BEARING HOUSING, COMPLETE
3	NPN	6	HCS, .375-16 UNC X 1
4	NPN	6	LOCK WASHER, .375
5	NPN	9	SHCS, M10X1.5 X 35
6	NPN	9	LOCK WASHER, M10

Motor Driveshaft

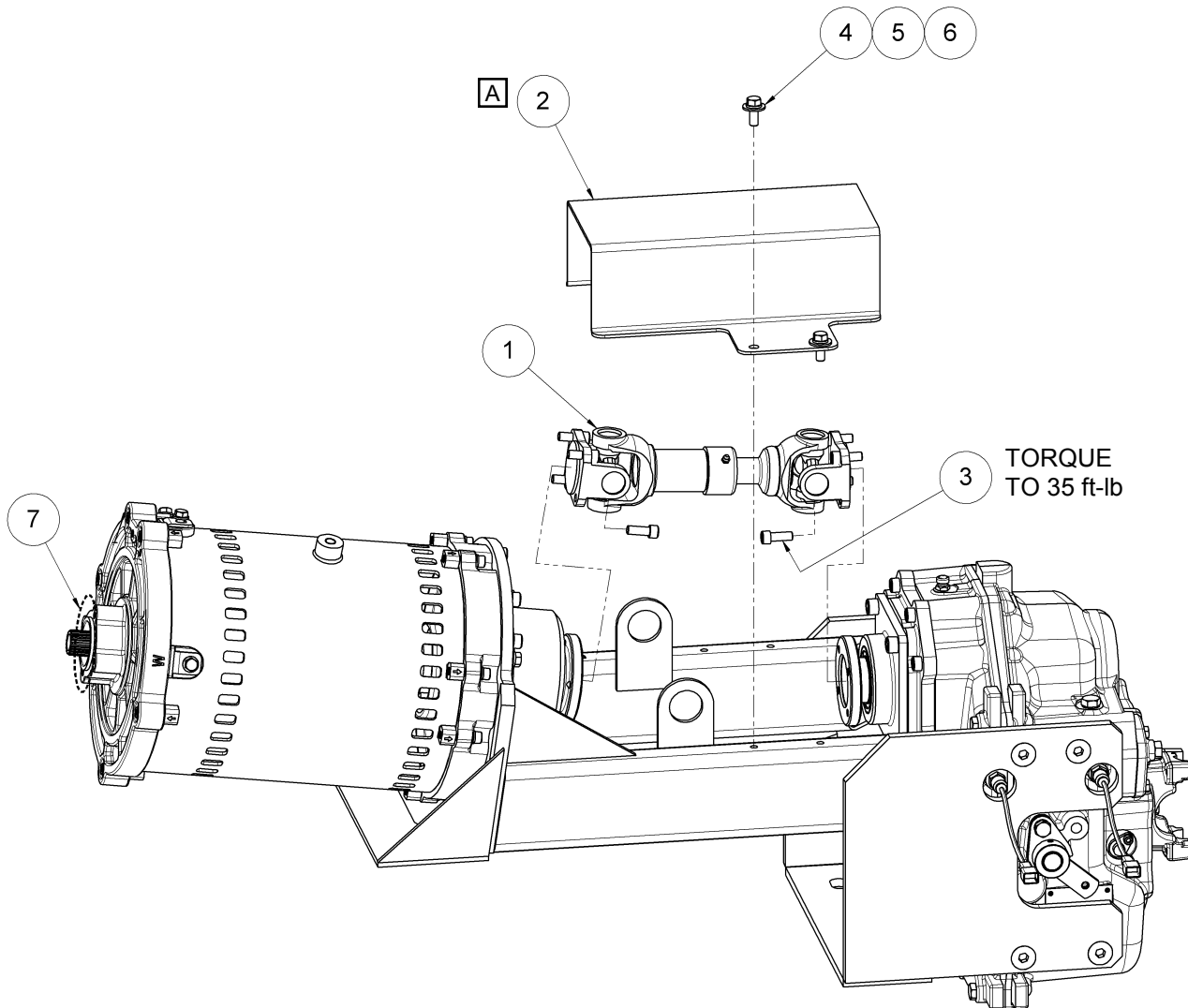

A Note correct part number for item 2 based on motor cradle part number.

Item	Part Number	Qty.	Description
1	A-ES12-0403	1	MOTOR DRIVESHAFT
2	A-ES12-0392	1	MOTOR DRIVESHAFT SHIELD (FOR A-ES12-0390 CRADLE ONLY)
2	ET00-03-004-SA	1	MOTOR DRIVESHAFT SHIELD (FOR ET00-03-001-SA CRADLE ONLY)
3	NPN	8	SHCS, .375-24 UNF X 1
4	NPN	4	HCS, .375-16 UNC X 1
5	NPN	4	LOCK WASHER, .375
6	NPN	4	FLAT WASHER, .375
7	ET00-54-001-CA	1	ENCODER BEARING

Motor Driveshaft Subassembly

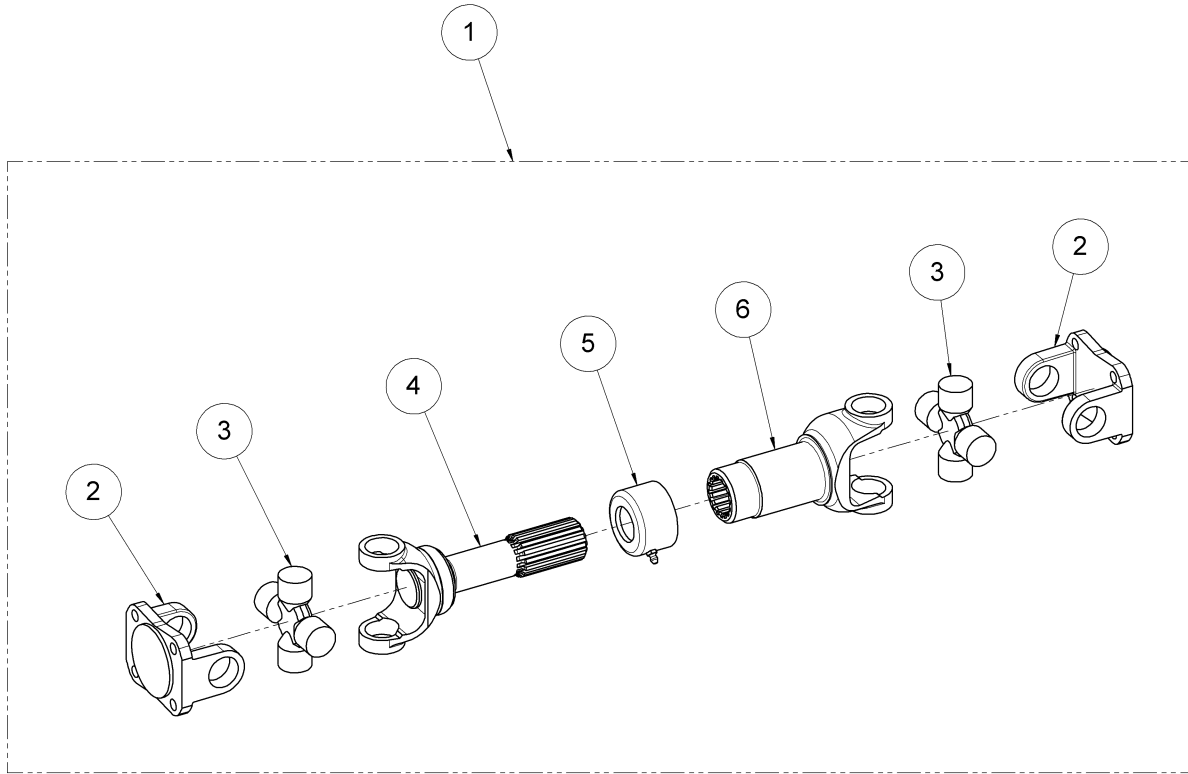

Item	Part Number	Qty.	Description
1	A-ES12-0403	1	MOTOR DRIVESHAFT COMPLETE
2	A-ES12-22459	2	FLANGE YOKE
3	A-ES12-1310	2	U-JOINT
4	A-ES12-28258X	1	YOKE SHAFT
5	A-ES12-21121X	1	DUST CAP
6	A-ES12-23128KX	1	SLIP YOKE

Cradle to Chassis

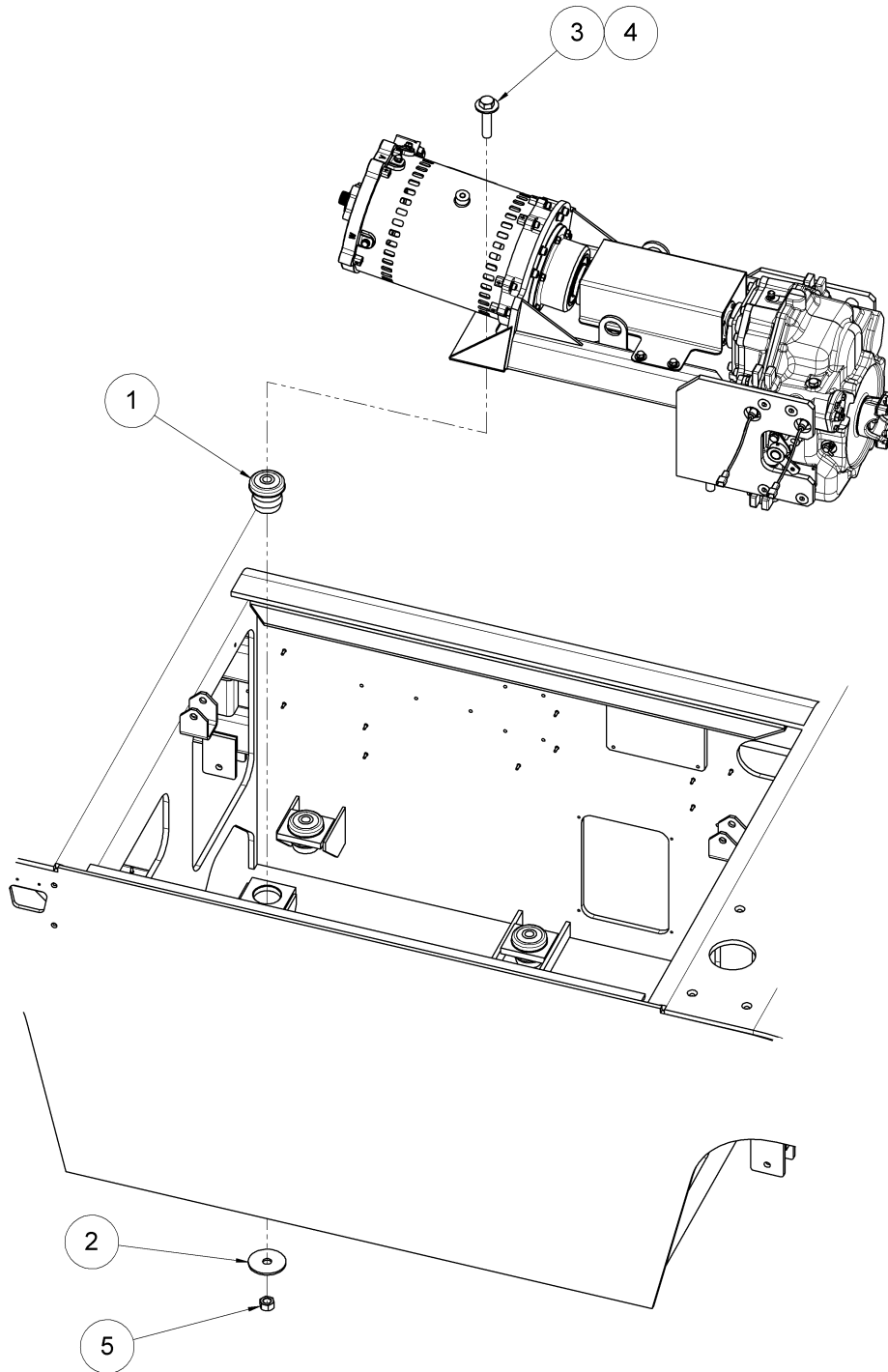

Item	Part Number	Qty.	Description
1	ET00-03-005-CA	4	ISOLATOR MOUNT
2	A-TT5D-00010	4	MOUNT WASHER
3	NPN	4	HCS, 3/4-10 UNC X 3.5
4	NPN	4	FLAT WASHER, 3/4
5	NPN	4	LOCK NUT, 3/4-10 UNC

eTT12 chassis shown, eTT8 and eTT16 chassis will differ.

Revision Log

Rev	Date	Description	Appr.
A	20-Feb-2014	Original release for production	PRB
B	04-Sep-2014	Added part number for motor encoder bearing	SEB
C	20-Jan-2015	Corrected hardware quantity, hardware lengths (cradle assy)	PRB
D	6-Jun-2016	Changed eXL16 model name to eTT16	TFP
E	23-Aug-2016	Corrected O-Ring part number.	TFP

Table of Contents

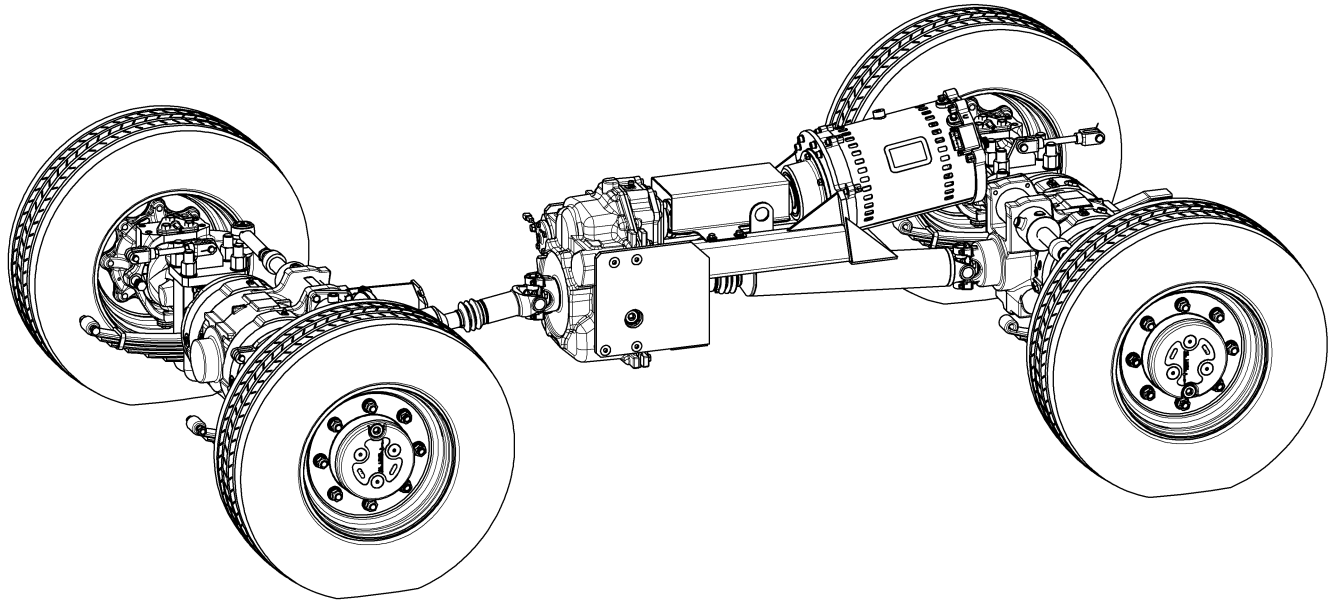

Section 3 - Drivetrain

Description	Page
FRONT AND REAR AXLE SUSPENSION	3-2
AXLE TO CHASSIS (FRONT AND REAR)	3-6
STEER SENSOR CONNECTOR (FRONT AND REAR)	3-7
FRONT AXLE PARKING BRAKE BRACKET	3-8
DRIVESHAFTS	3-9
FRONT DRIVESHAFT ASSEMBLY	3-10
REAR DRIVESHAFT ASSEMBLY	3-11
WHEELS AND TIRES	3-12
REVISION LOG	3-13

Front Axle Suspension

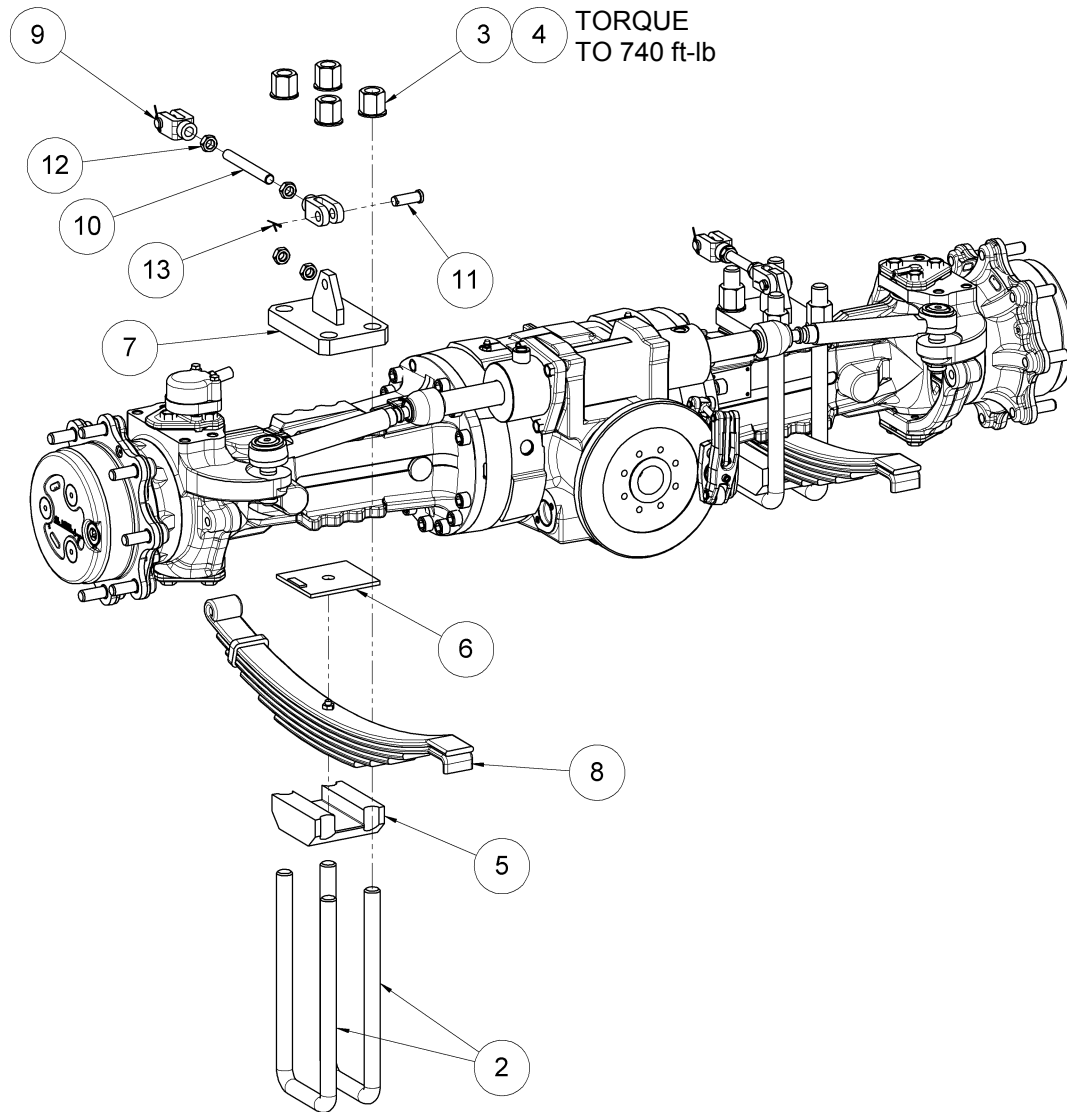

Item	Part Number	Qty.	Description
1	A-ES12-0430	1	FRONT AXLE
2	A-ES12-0510	2	1-14 UNS U-BOLT KIT (2 BOLTS, 4 WASHERS, 4 NUTS)
3	NPN	4	FLAT WASHER, 1 (INCLUDED WITH ITEM 2)
4	NPN	4	HIGH NUT, 1-14 UNS (INCLUDED WITH ITEM 2)
5	A-ES12-0345	2	AXLE MOUNTING PLATE
6	A-ES12-0350	2	AXLE MOUNTING PLATE, KEYED
7	A-ES12-0355	2	AXLE MOUNTING PLATE, TOP
8	A-TT10-00116	2	LEAF SPRING
9	A-ES12-0530	4	YOKE END
10	A-ES12-0533	2	5/8-18 UNF THREADED ROD (5 3/8 LONG)
11	A-ES12-0532	4	CLEVIS PIN
12	A-ES12-0534	4	JAM NUT, 5/8-18 UNF
13	NPN	4	COTTER PIN, 9/64 X 2

Rear Axle Suspension

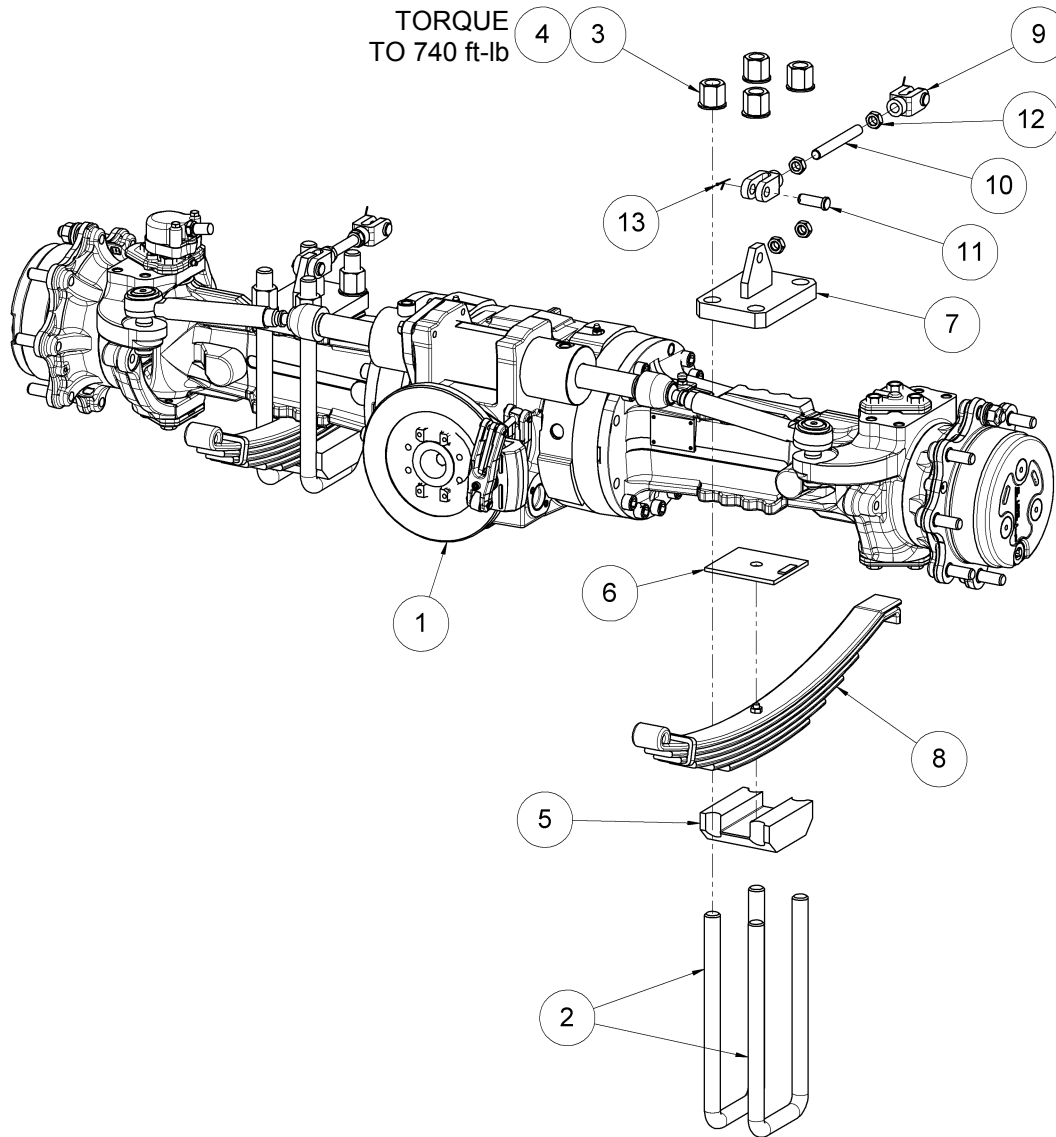

Item	Part Number	Qty.	Description
1	A-ES12-0432	1	REAR AXLE
2	A-ES12-0510	2	1-14 UNS U-BOLT KIT (2 BOLTS, 4 WASHERS, 4 NUTS)
3	NPN	4	FLAT WASHER, 1 (INCLUDED WITH ITEM 2)
4	NPN	4	HIGH NUT, 1-14 UNS (INCLUDED WITH ITEM 2)
5	A-ES12-0345	2	AXLE MOUNTING PLATE
6	A-ES12-0350	2	AXLE MOUNTING PLATE, KEYED
7	A-ES12-0355	2	AXLE MOUNTING PLATE, TOP
8	A-TT10-00116	2	LEAF SPRING
9	A-ES12-0530	4	YOKE END
10	A-ES12-0533	2	5/8-18 UNF THREADED ROD (6 5/8 LONG)
11	A-ES12-0532	4	CLEVIS PIN
12	A-ES12-0534	4	JAM NUT, 5/8-18 UNF
13	NPN	4	COTTER PIN, 9/64 X 2

Front Axle Suspension

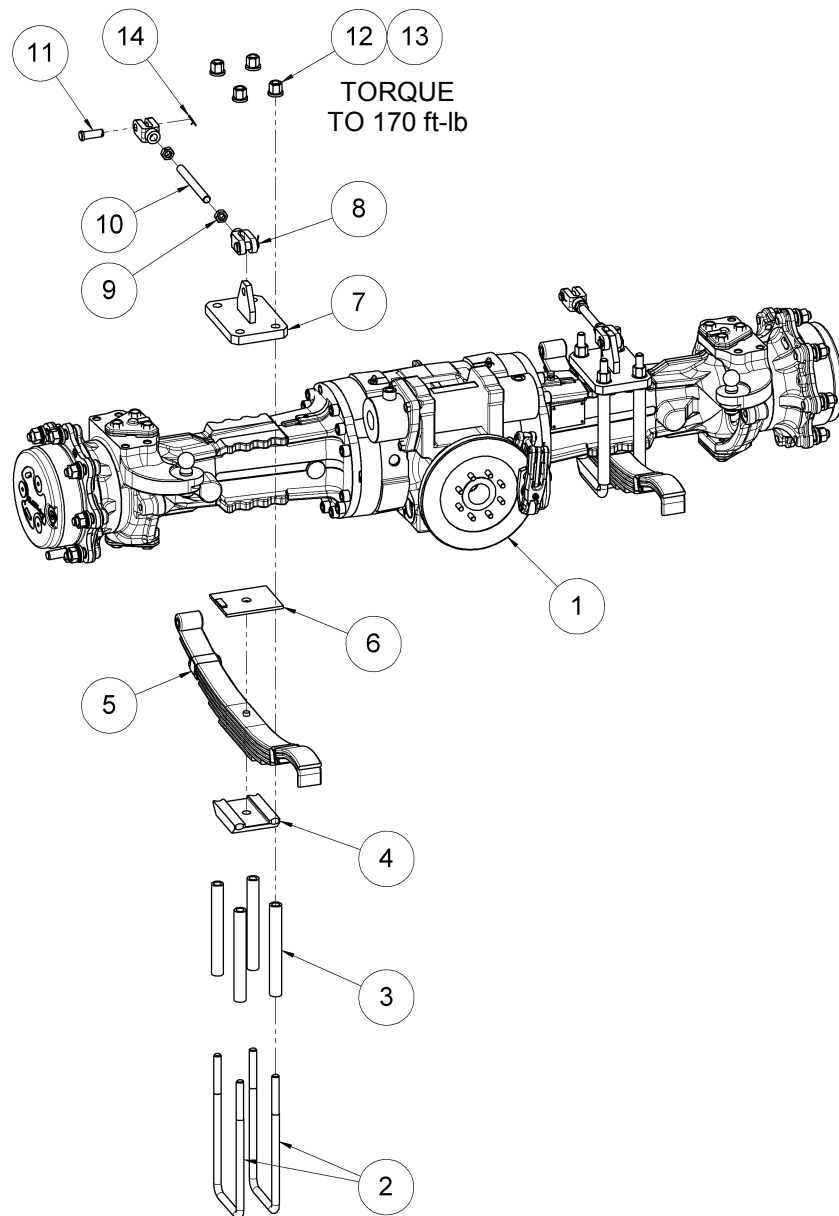

Item	Part Number	Qty.	Description
1	A-ES12-0430	1	FRONT AXLE
2	ET12-04-003-SA	2	5/8-18 UNF U-BOLT KIT (2 BOLTS, 4 WASHERS, 4 NUTS)
3	ET12-04-004-SA	4	U-BOLT SPACER
4	ET12-04-001-SA	4	AXLE MOUNTING PLATE
5	A-TT10-00116	2	LEAF SPRING
6	A-ES12-0350	2	AXLE MOUNTING PLATE, KEYED
7	ET12-04-002-SA	2	AXLE MOUNTING PLATE, TOP
8	A-ES12-0530	4	YOKE END
9	A-ES12-0534	4	JAM NUT, 5/8-18 UNF
10	A-ES12-0533	2	5/8-18 UNF THREADED ROD (5 3/8 LONG)
11	A-ES12-0532	4	CLEVIS PIN
12	NPN	4	FLAT WASHER, 5/8 (INCLUDED WITH ITEM 2)
13	NPN	4	HIGH NUT, 5/8-18 UNF (INCLUDED WITH ITEM 2)
14	NPN	4	COTTER PIN, 9/64 X 2

Rear Axle Suspension

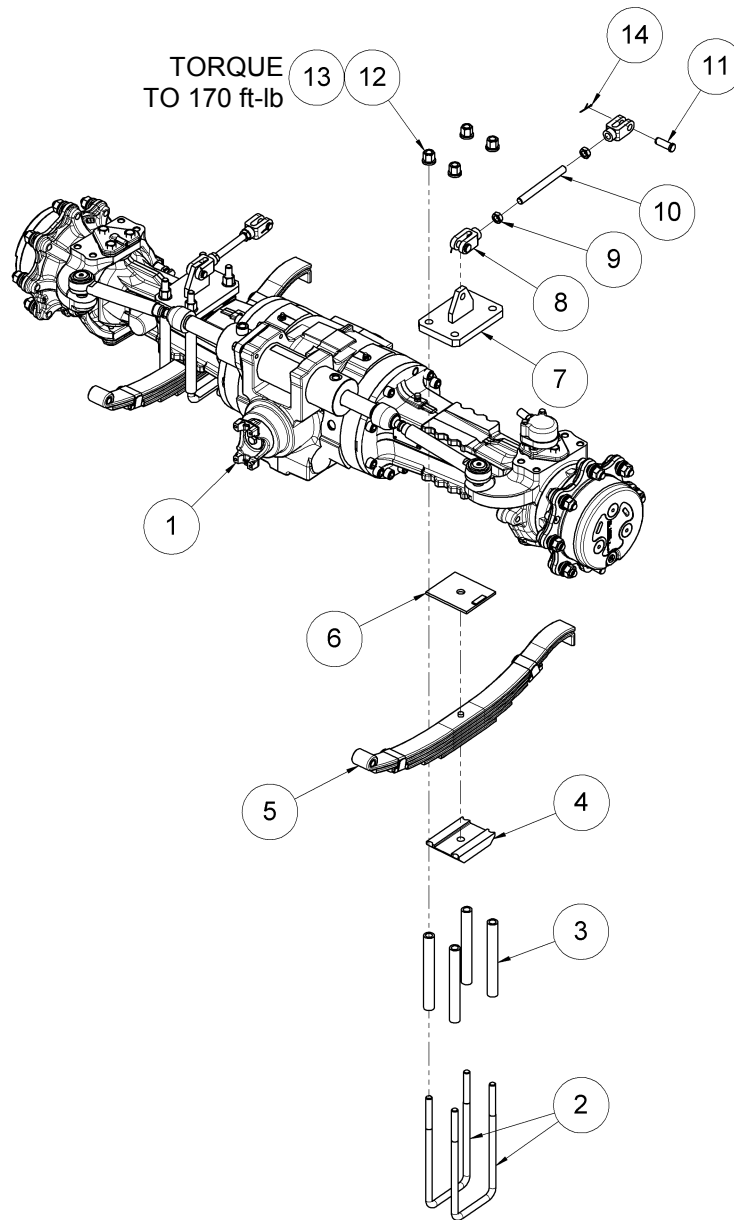

Item	Part Number	Qty.	Description
1	A-ES12-0432	1	REAR AXLE
2	ET12-04-003-SA	2	5/8-18 UNF U-BOLT KIT (2 BOLTS, 4 WASHERS, 4 NUTS)
3	ET12-04-004-SA	4	U-BOLT SPACER
4	ET12-04-001-SA	4	AXLE MOUNTING PLATE
5	A-TT10-00116	2	LEAF SPRING
6	A-ES12-0350	2	AXLE MOUNTING PLATE, KEYED
7	ET12-04-002-SA	2	AXLE MOUNTING PLATE, TOP
8	A-ES12-0530	4	YOKE END
9	A-ES12-0534	4	JAM NUT, 5/8-18 UNF
10	A-ES12-0533	2	5/8-18 UNF THREADED ROD (5 3/8 LONG)
11	A-ES12-0532	4	CLEVIS PIN
12	NPN	4	FLAT WASHER, 5/8 (INCLUDED WITH ITEM 2)
13	NPN	4	HIGH NUT, 5/8-18 UNF (INCLUDED WITH ITEM 2)
14	NPN	4	COTTER PIN, 9/64 X 2

Axle to Chassis (Front and Rear)

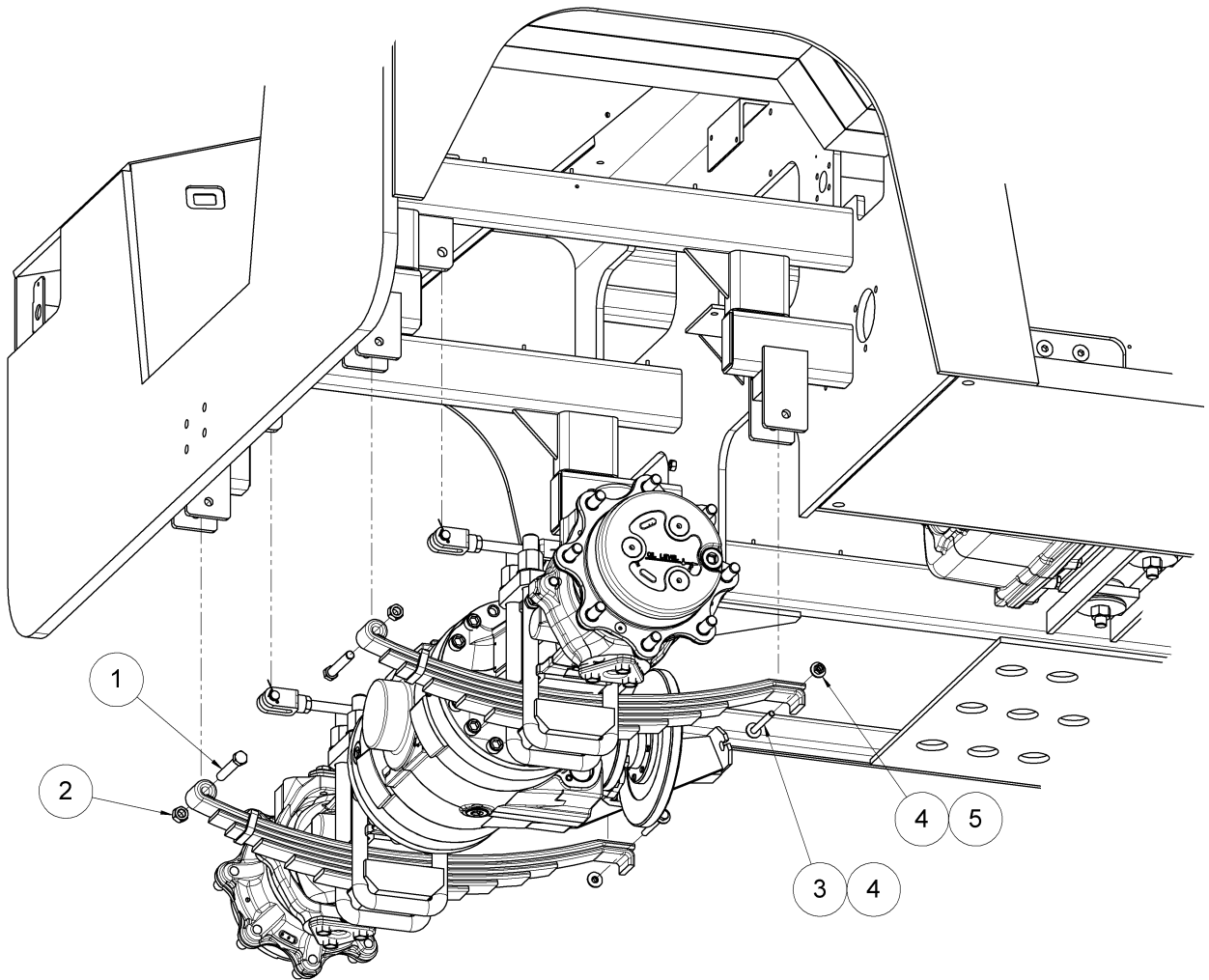

Item	Part Number	Qty.	Description
1	NPN	2	HCS, 9/16-18 UNC X 3.5, GR 8
2	NPN	2	LOCK NUT, 9/16-18 UNC
3	NPN	2	HCS, 3/8-16 UNC X 3.5, GR 8
4	NPN	4	FLAT WASHER, 3/8
5	NPN	2	LOCK NUT, 3/8-16 UNC

eTT12 chassis shown, eTT16 chassis will differ. Note that front and rear axles share the same hardware and installation type.

Anti-rotation links must be adjusted to length while the axle is in ride location (springs compressed).

Steer Sensor Connector (Front and Rear)

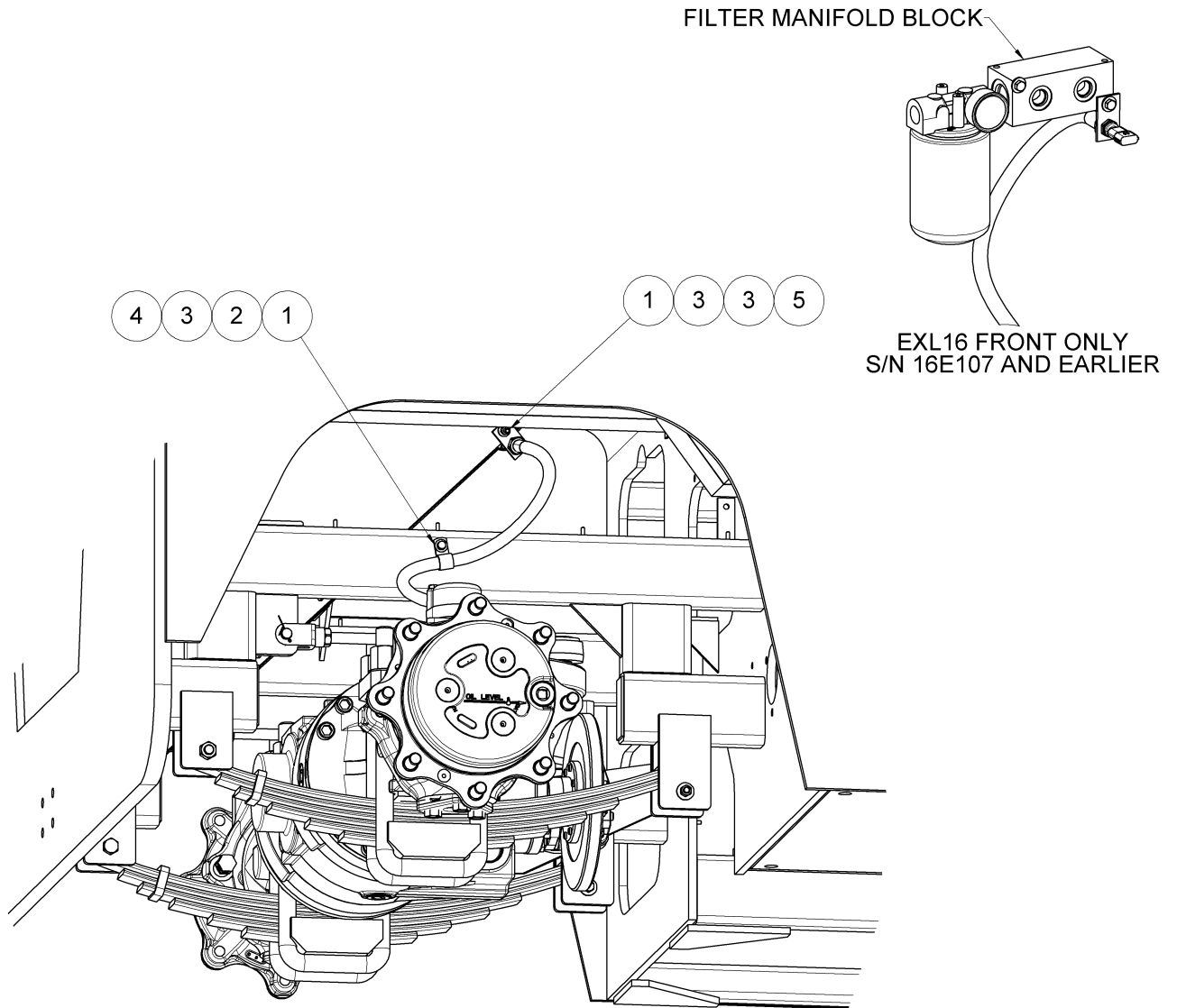

Item	Part Number	Qty.	Description
1	NPN		HCS, 1/4-20 UNC X 1
2	NPN		LOCK WASHER, 1/4
3	NPN		FLAT WASHER, 1/4
4	NPN		CUSHIONED LOOP CLAMP, 3/4
5	NPN		LOCK NUT, 1/4-20 UNC

Note that front and rear sensors share the same hardware and installation type.

Front Axle Parking Brake Bracket

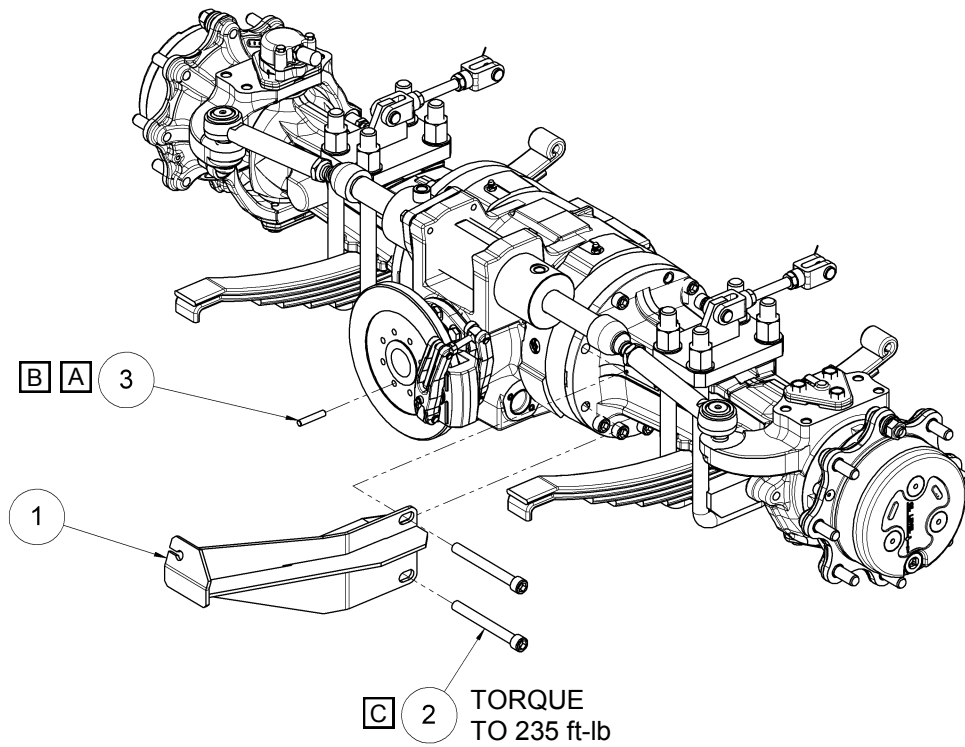

- A** Remove and discard the factory installed M10x25 HCS securing the brake disc in place.
- B** Install specified components using Loctite® Threadlocker Red 271® thread retaining compound or comparable.
- C** Remove the two M16x150 axle bolts as shown and re-install through item 1 to the axle.

Item	Part Number	Qty.	Description
1	A-ES12-0155	1	PARKING BRAKE AXLE BRACKET
2	NPN	2	SCS, M16X2.0 X 150, GR 10.9 (INCLUDED WITH AXLE)
3	A-ES12-0397	8	STUD, M10X1.5 X 52

Driveshafts

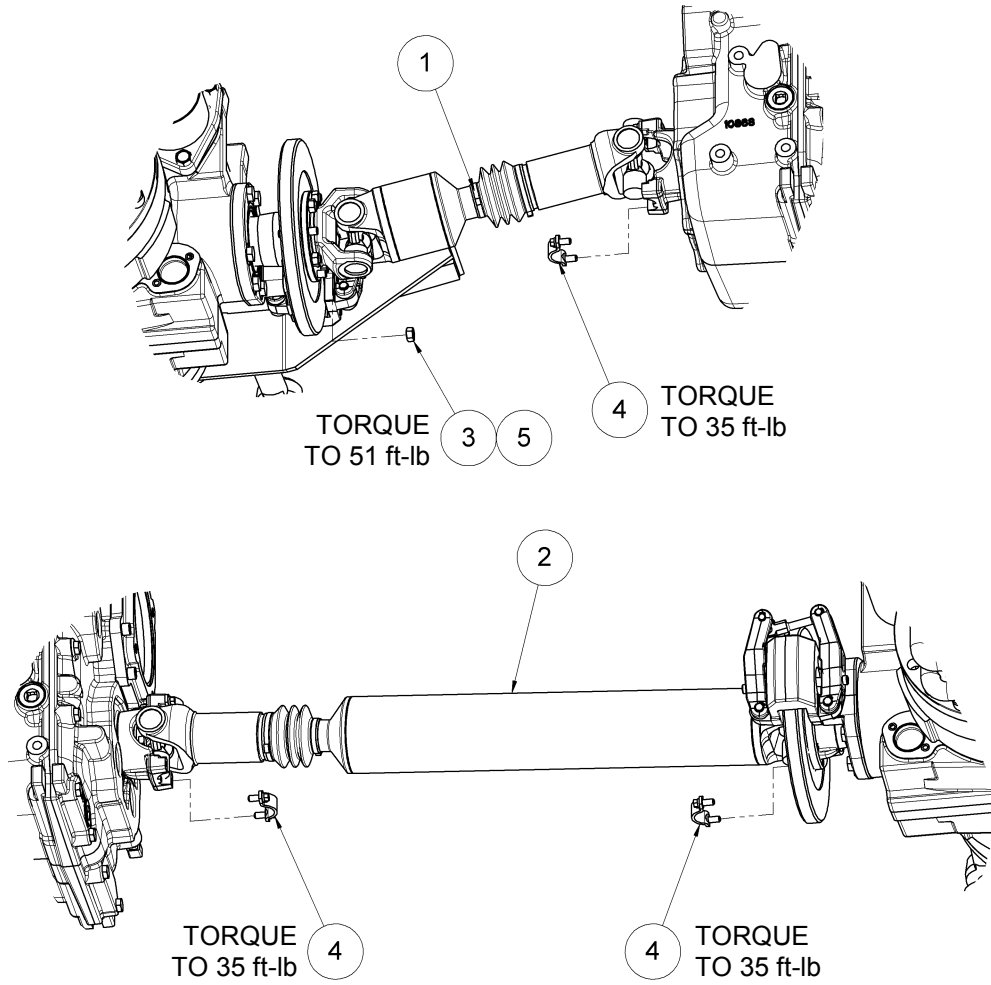

Item	Part Number	Qty.	Description
1	A-ES12-0401	1	FRONT DRIVESHAFT
2	A-ES12-0402	1	REAR DRIVESHAFT
3	A-ES12-0398	8	HEX NUT, M10X1.5, GR 10.9
4	A-TT4-00130	3	U-JOINT STRAP KIT, 1410
5	NPN	8	LOCK WASHER, M10

Front Driveshaft Subassembly

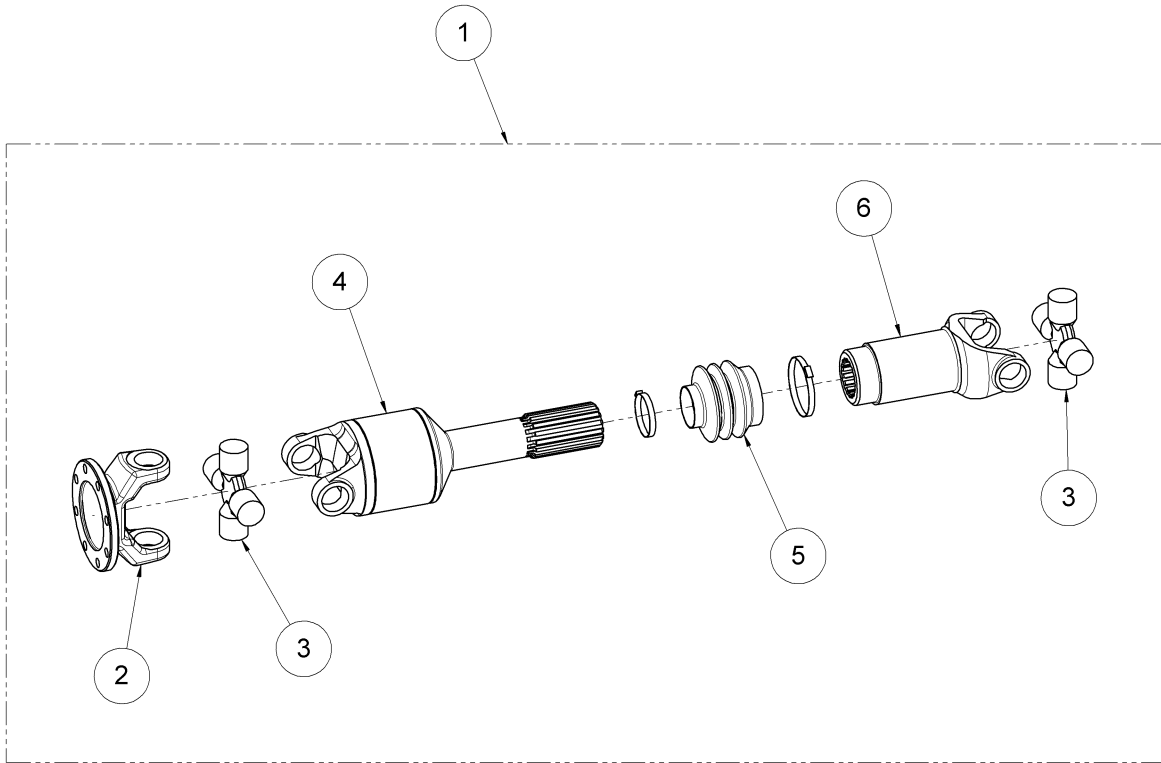

Item	Part Number	Qty.	Description
1	A-ES12-0401	1	FRONT DRIVESHAFT - COMPLETE
2	A-ES12-321159	1	FLANGE YOKE
3	A-ES12-5801X	2	U-JOINT
4	A-ES12-0401-A	1	SHAFT YOKE
5	A-ES12-211932X	1	BOOT
6	A-ES12-33118KX	1	SLIP YOKE

Rear Driveshaft Subassembly

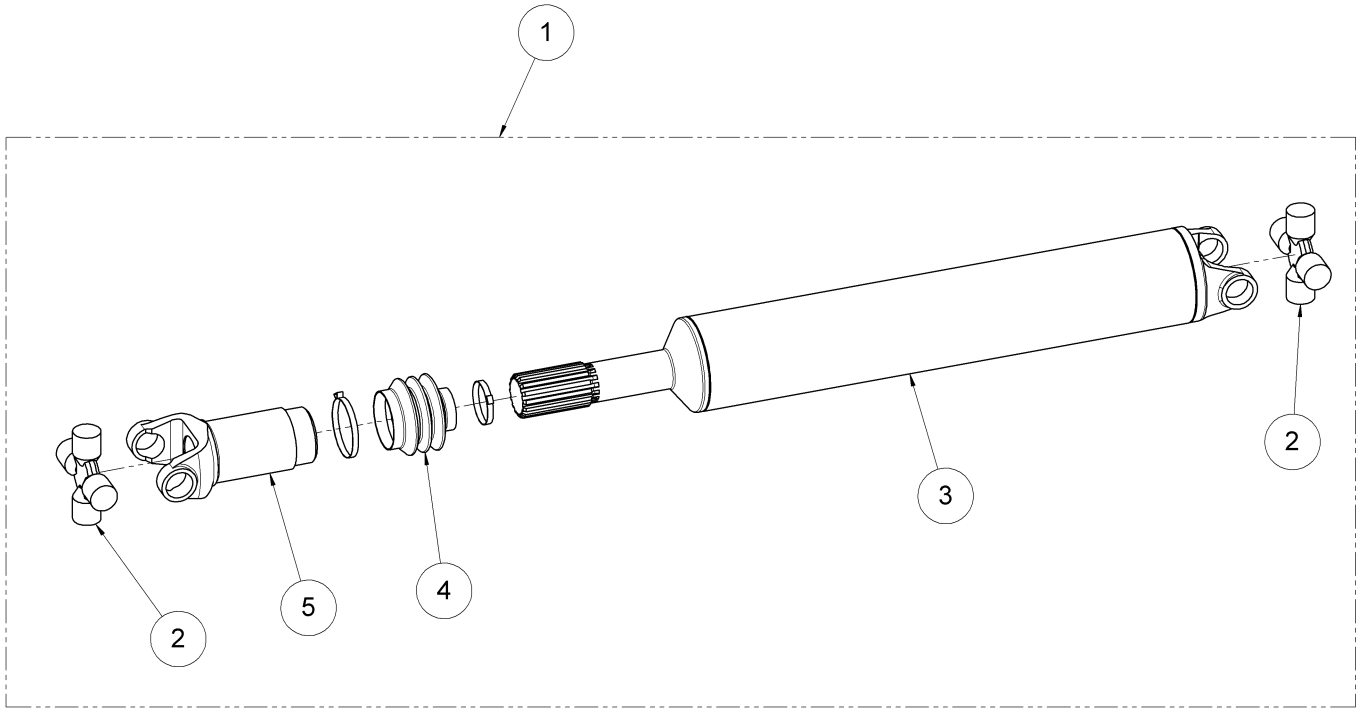

Item	Part Number	Qty.	Description
1	A-ES12-0402	1	REAR DRIVESHAFT - COMPLETE
2	A-ES12-5801X	2	U-JOINT
3	A-ES12-0402-A	1	SHAFT YOKE TUBE WELDMENT
4	A-ES12-211932X	1	BOOT
5	A-ES12-33118KX	1	SLIP YOKE

Wheels and Tires

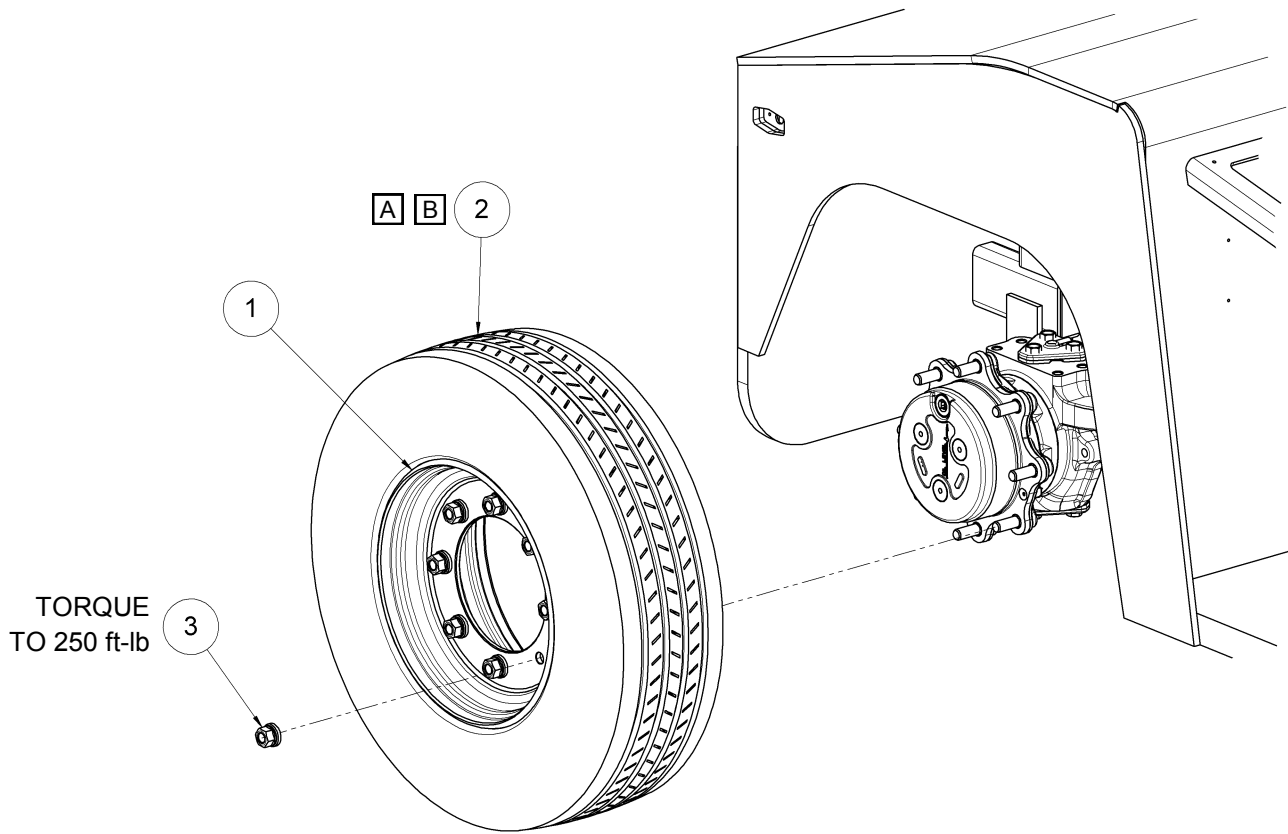

TORQUE
TO 250 ft-lb

- A** Inflate per sidewall specifications.
- B** When replacing tires with a different model, verify that capacity is sufficient for the tractor weight. Refer to the tractor data plate for gross vehicle weight.

Item	Part Number	Qty.	Description
1	A-ES12-0520	4	WHEEL, 6.75 X 16.5 (ETT12 ONLY)
1	EX16-04-001-SA	4	WHEEL, 6.75 X 17.5 (ETT16 ONLY)
2	A-TT10-00121	4	TIRE, 9.50 X 16.5, LOAD RANGE E (ETT12 ONLY)
2	EX16-04-002-CA	4	TIRE, 215/75R17.5, LOAD RANGE F (ETT16 ONLY)
3	A-ES12-121746	32	WHEEL NUT, M18X1.5 PER DIN 74 361 FORM H

eTT12 chassis shown, eTT16 chassis will differ.

Revision Log

Rev	Date	Description	Appr.
A	21-Feb-2014	Original release for production	PRB
B	17-Apr-2015	Added missing lock washers to Driveshaft Assembly.	DCM
C	22-May-2015	Updated for eTT12G / eXL16G tractors.	DCM
D	21-Oct-2015	Added wheel nut part number.	DCM
E	6-Jun-2016	Changed eXL16 model name to eTT16	TFP

This page intentionally left blank.

Section 4 - Electrical Subassemblies	
Description	Page
Traction Drive Subassembly	4-2
Contactors and Fuses	4-4
Charge Jack Assembly	4-8
Dash Panel Subassembly	4-10
Power Distribution Box	4-12
Revision Log	4-18

Traction Drive Subassembly

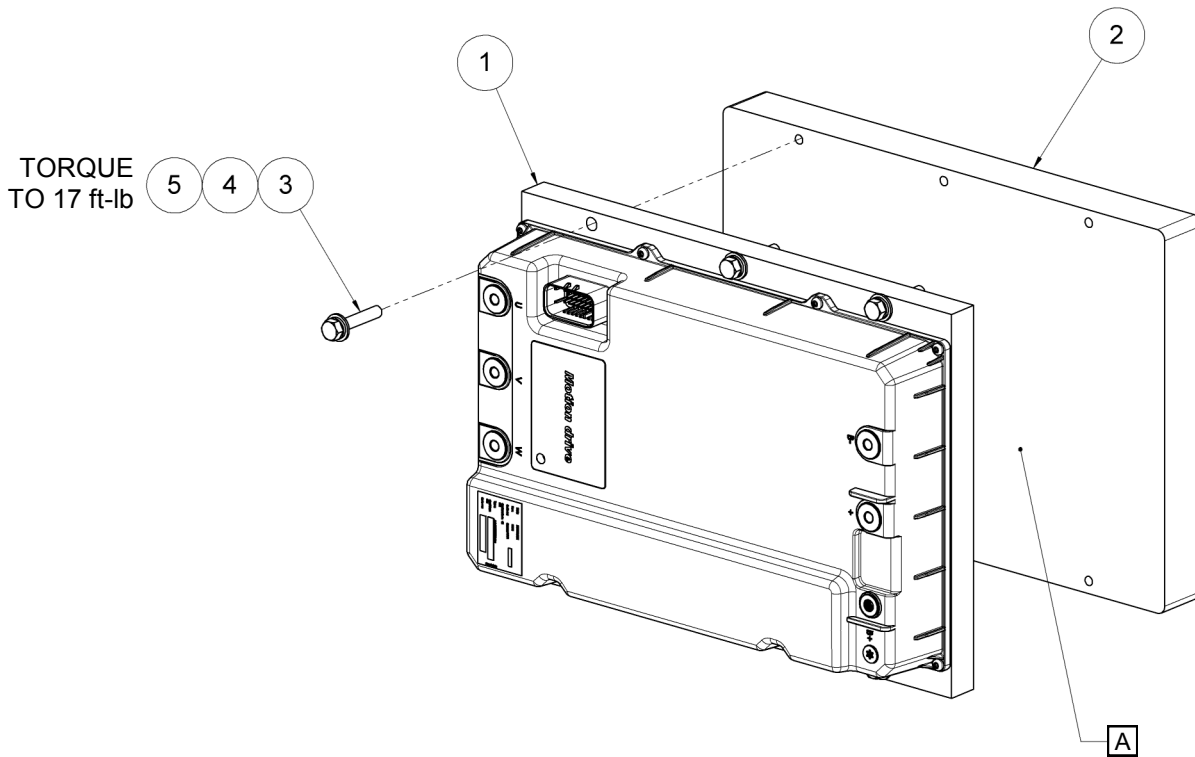

A Apply 1/2 fl oz. (30 grams) of Dow Corning® 340 Heat Sink Compound or equivalent to the interface between items 1 and 2. The thermal compound should be applied evenly over the entire mating surface.

Item	Part Number	Qty.	Description
1	NVSP-10-001-CA	1	TRACTION MOTOR DRIVE (FLAT HEATSINK)
2	A-ES12-0418	1	AUXILLIARY HEATSINK
3	NPN	6	HCS, 5/16-18 UNC X 1.75
4	NPN	6	LOCK WASHER, 5/16
5	NPN	6	FLAT WASHER, 1/4

Traction Drive Subassembly

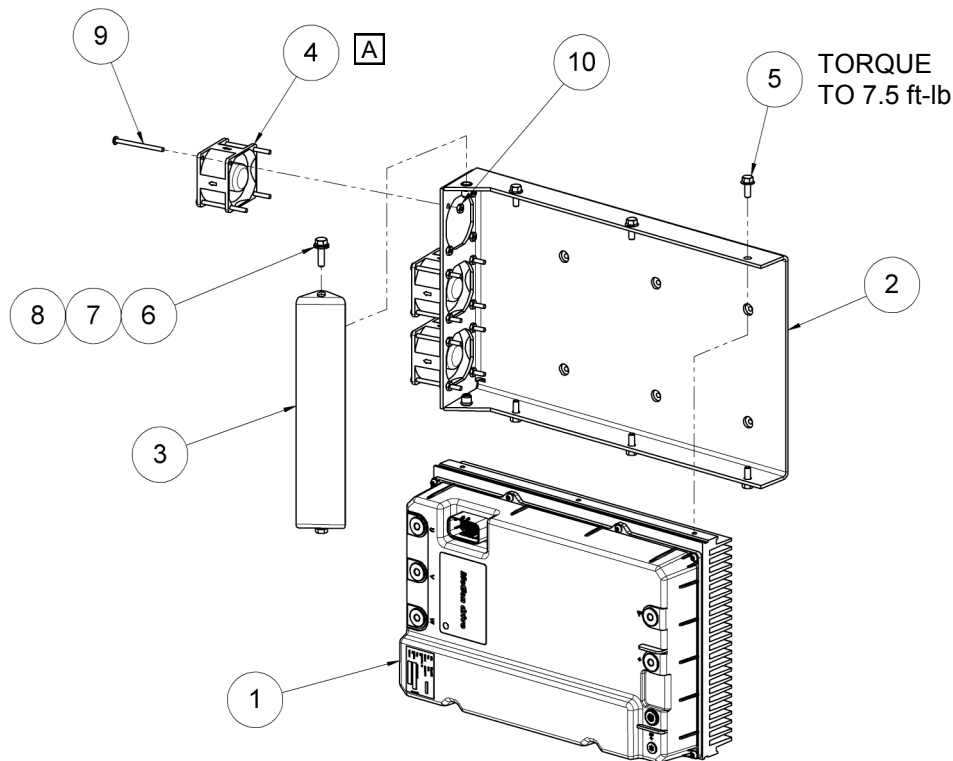

A Fans must be installed with airflow direction away from drive.

Item	Part Number	Qty.	Description
1	A-ES12-0422	1	TRACTION MOTOR DRIVE (FINNED HEATSINK)
2	ET00-10-001-SA	1	DRIVE MOUNT
3	ET00-10-003-SA	1	PLENUM COVER
4	A-ES12-0806	3	COOLING FAN
5	NPN	6	HCS, M6X1.0 X 16
6	NPN	2	HCS, 1/4-20 UNC X 1
7	NPN	2	LOCK WASHER, 1/4
8	NPN	2	FLAT WASHER, 1/4
9	NPN	12	BHS, #8-32 UNC X 2.25
10	NPN	12	LOCK NUT, #8-32 UNC
N/A	DTM04-2P	3	ELECTRICAL CONNECTOR (INSTALLED TO ITEM 4)
N/A	WM2P	3	CONNECTOR LOCK (INSTALLED TO ITEM 4)
N/A	0460-202-20141	6	CONNECTOR PIN (INSTALLED TO ITEM 4)

Item 4 to be wired as shown below:

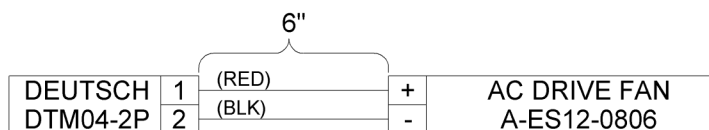

Contactors and Fuses

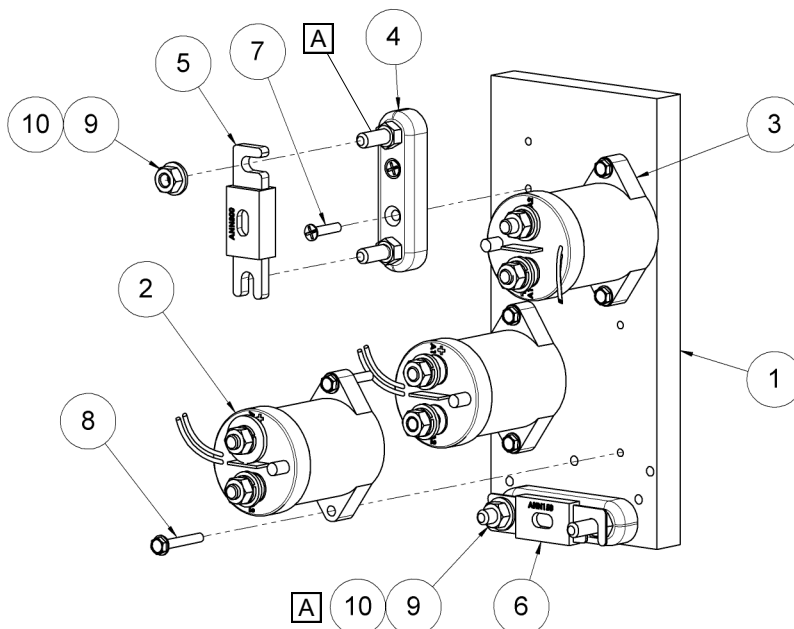

A If a dual battery option is required, this lug must be replaced with 1.5 inch long bolt.

Item	Part Number	Qty.	Description
1	A-ES12-0570	1	BUSBAR MOUNTING PLATE
2	A-ES12-0416-1	2	CONTACTOR, 24V COIL
3	A-ES12-0415-1	1	CONTACTOR, 12V COIL
4	A-MTT5-0225	2	ANN FUSE HOLDER
5	A-ES12-0423	1	800 AMP ANN FUSE
6	A-ES12-0419	1	150 AMP ANN FUSE (DC HYDRAULIC PUMP)
6	A-ES12-0419-1	1	250 AMP ANN FUSE (AC HYDRAULIC PUMP)
7	NPN	4	FHS, #10-32 UNF X .875
8	NPN	6	HCS, #10-32 UNF X .875
9	NPN	2	FLAT WASHER, 5/16 (INCLUDED WITH FUSE HOLDER)
10	NPN	2	HEX NUT, 5/16 (INCLUDED WITH FUSE HOLDER)
N/A	DT06-2S	2	ELECTRICAL CONNECTOR (INSTALLED TO ITEM 2)
N/A	W2S	2	CONNECTOR LOCK (INSTALLED TO ITEM 2)
N/A	0462-201-16141	4	CONNECTOR PINS (INSTALLED TO ITEM 2)
N/A	DT04-2P	1	ELECTRICAL CONNECTOR (INSTALLED TO ITEM 3)
N/A	W2P	1	CONNECTOR LOCK (INSTALLED TO ITEM 3)
N/A	0460-202-16141	2	CONNECTOR PINS (INSTALLED TO ITEM 3)

Item 2 to be wired as shown below.

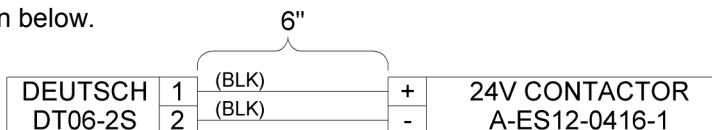

Item 3 to be wired as shown below.

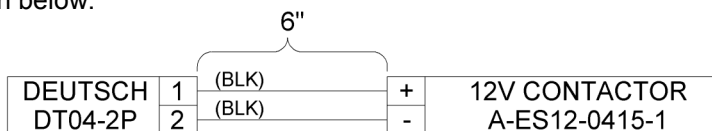

Contactors and Fuses - Rigid Bus bars

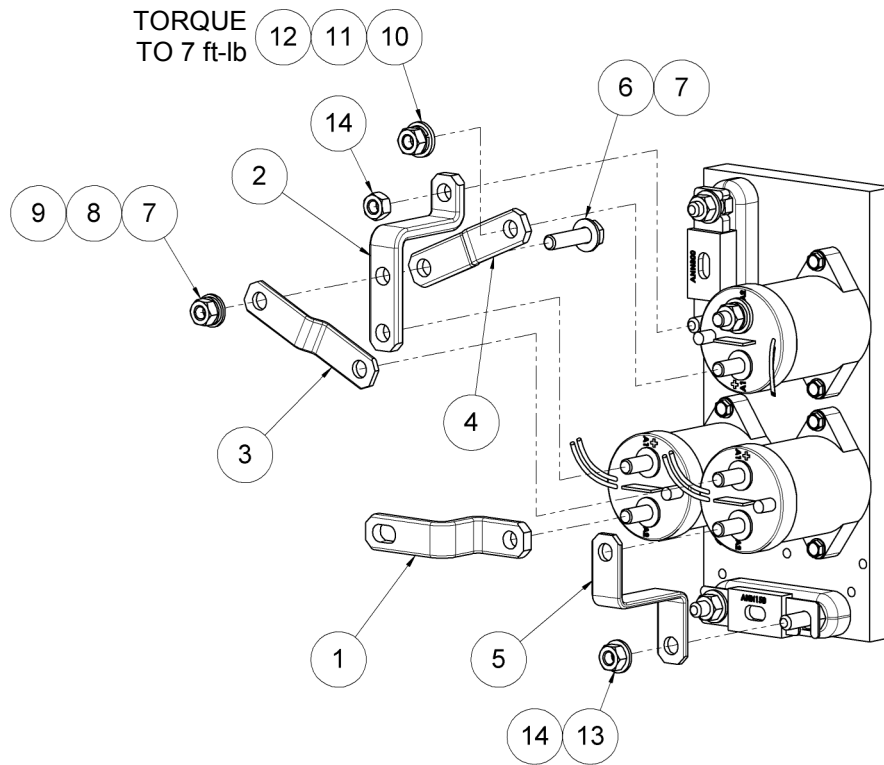

Rigid bus bars are being phased out and being replaced with flexible ones. Please see the next page for equivalent replacement parts.

Item	Part Number	Qty.	Description
1	A-ES12-0571, DET A	1	BUS BAR A
2	A-ES12-0571, DET B	1	BUS BAR B
3	A-ES12-0571, DET C	1	BUS BAR C
4	A-ES12-0571, DET D	1	BUS BAR D
5	A-ES12-0571, DET E	1	BUS BAR E
6	NPN	1	HCS, 5/16-18 UNC X 1.25
7	NPN	2	FLAT WASHER, 5/16
8	NPN	1	LOCK WASHER, 5/16
9	NPN	1	HEX NUT, 5/16-18 UNC
10	NPN	2	HEX NUT, M8X1.25 (INCLUDED WITH CONTACTOR)
11	NPN	2	LOCK WASHER, M8 (INCLUDED WITH CONTACTOR)
12	NPN	2	FLAT WASHER, M8 (INCLUDED WITH CONTACTOR)
13	NPN	1	FLAT WASHER, 5/16 (INCLUDED WITH FUSE HOLDER)
14	NPN	2	HEX NUT, 5/16 (INCLUDED WITH FUSE HOLDER)

Contactors and Fuses - Flexible Bus bars

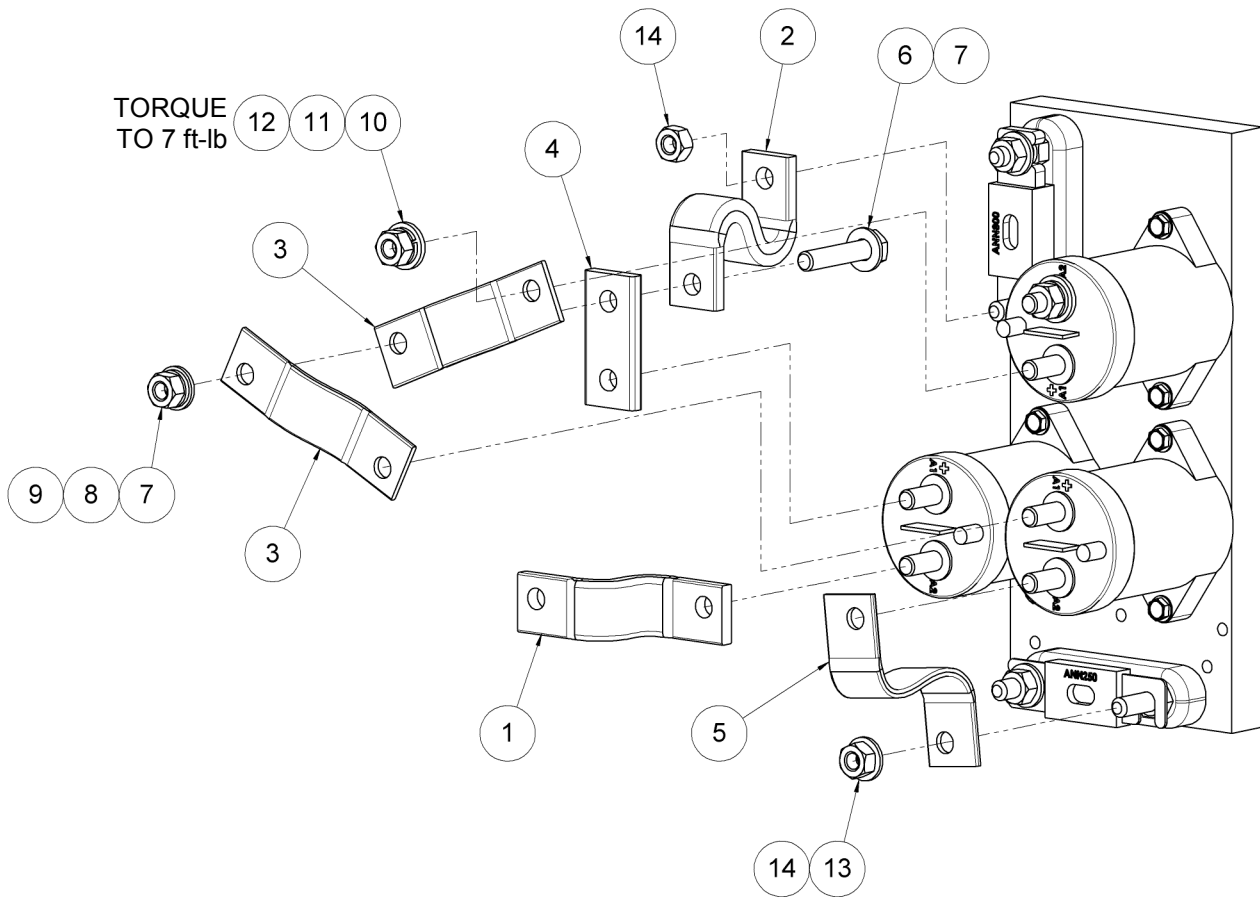

Item	Part Number	Qty.	Description
1	ET00-05-004-SA	1	FLEXIBLE POWER CABLE, TRACTION CONTACTOR TO DRIVE
2	ET00-05-006-SA	1	FLEXIBLE POWER CABLE, JUNCTION TO MAIN FUSE
3	ET00-05-005-SA	2	FLEXIBLE POWER CABLE, JUNCTION TO CONTACTOR
4	ET00-05-003-SA	1	BUS BAR, CONTACTOR TO JUNCTION
5	ET00-05-007-SA	1	FLEXIBLE POWER CABLE, PUMP CONTACTOR TO FUSE
6	NPN	1	HCS, 5/16-18 UNC X 1.5
7	NPN	2	FLAT WASHER, 5/16
8	NPN	1	LOCK WASHER, 5/16
9	NPN	1	HEX NUT, 5/16-18 UNC
10	NPN	2	HEX NUT, M8X1.25 (INCLUDED WITH CONTACTOR)
11	NPN	2	LOCK WASHER, M8 (INCLUDED WITH CONTACTOR)
12	NPN	2	FLAT WASHER, M8 (INCLUDED WITH CONTACTOR)
13	NPN	1	FLAT WASHER, 5/16 (INCLUDED WITH FUSE HOLDER)
14	NPN	2	HEX NUT, 5/16 (INCLUDED WITH FUSE HOLDER)

Contactors and Fuses

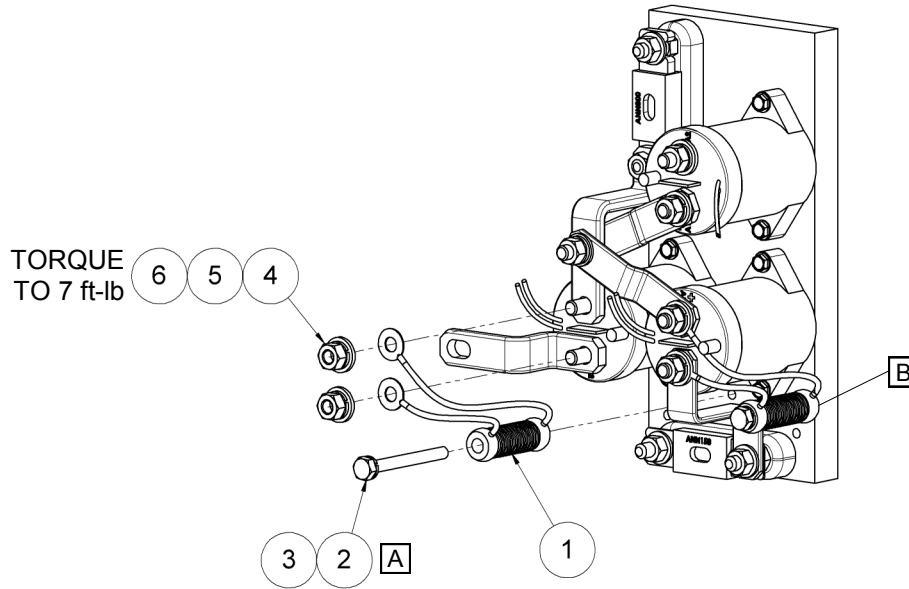

- A** Tighten item 2 only enough to fully compress the spring lock washer.
- B** This resistor only is not present on tractors with DC hydraulic pump.

Item	Part Number	Qty.	Description
1	A-RTT12-00429	2	PRE-CHARGE RESISTOR
2	NPN	2	HCS, 1/4-20 UNC X 2.50
3	NPN	2	LOCK WASHER, 1/4
4	NPN	4	HEX NUT, M8X1.25 (INCLUDED WITH CONTACTOR)
5	NPN	4	LOCK WASHER, M8 (INCLUDED WITH CONTACTOR)
6	NPN	4	FLAT WASHER, M8 (INCLUDED WITH CONTACTOR)

Item 1 to be wired as shown below.

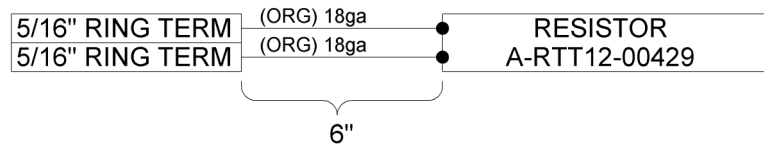

Charge Jack Assembly

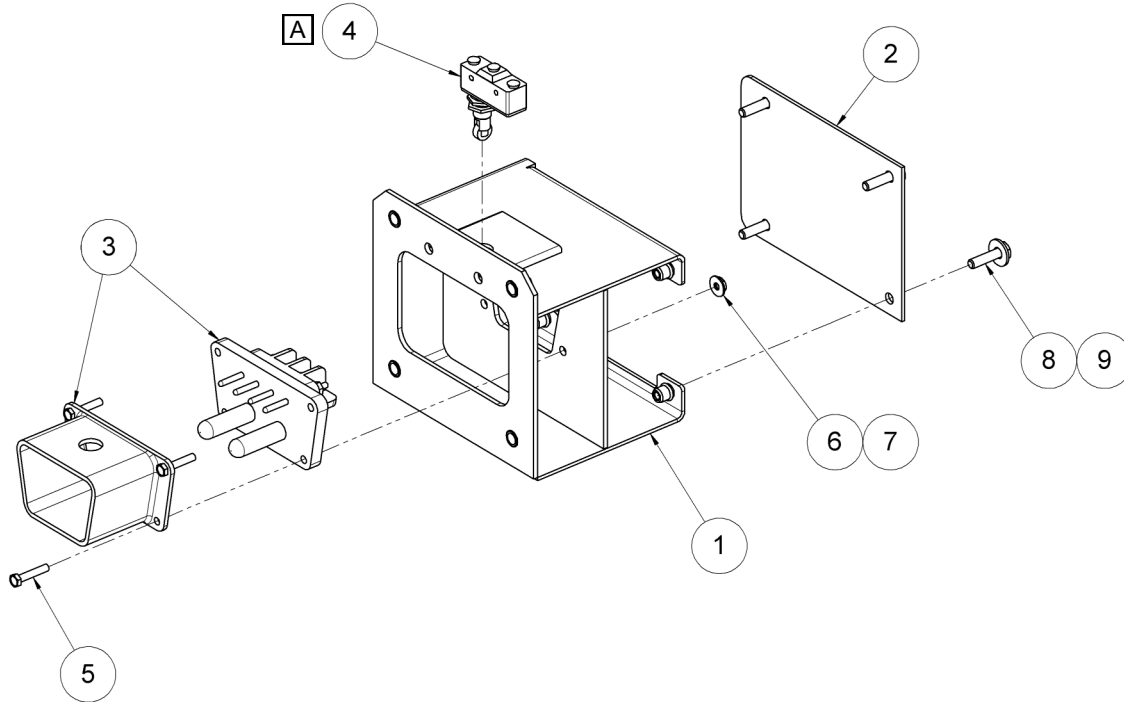

A Adjust switch position to put the roller wheel centerline just outside the Burton socket.

Item	Part Number	Qty.	Description
1	A-MTT5-0217	1	CHARGE JACK WELDMENT
2	A-MTT5-0218	1	CHARGE JACK COVER
3	A-ES12-0442	1	BURTON CONNECTOR
4	A-ES12-0445	1	LIMIT SWITCH
5	NPN	4	HCS, #10-32 UNF X 1
6	NPN	4	FLAT WASHER, #10
7	NPN	4	LOCK NUT, #10-32 UNF
8	NPN	4	HCS, 1/4-20 UNC X 1
9	NPN	4	FLAT WASHER, 1/4
N/A	DT04-2P	1	ELECTRICAL CONNECTOR (INSTALLED TO ITEM 4)
N/A	W2P	1	CONNECTOR LOCK (INSTALLED TO ITEM 4)
N/A	0460-215-16141	2	CONNECTOR PINS (INSTALLED TO ITEM 4)

Item 4 to be wired as shown below.

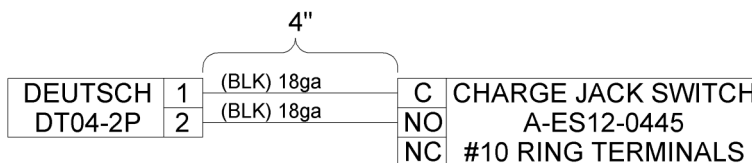

Charge Jack Assembly

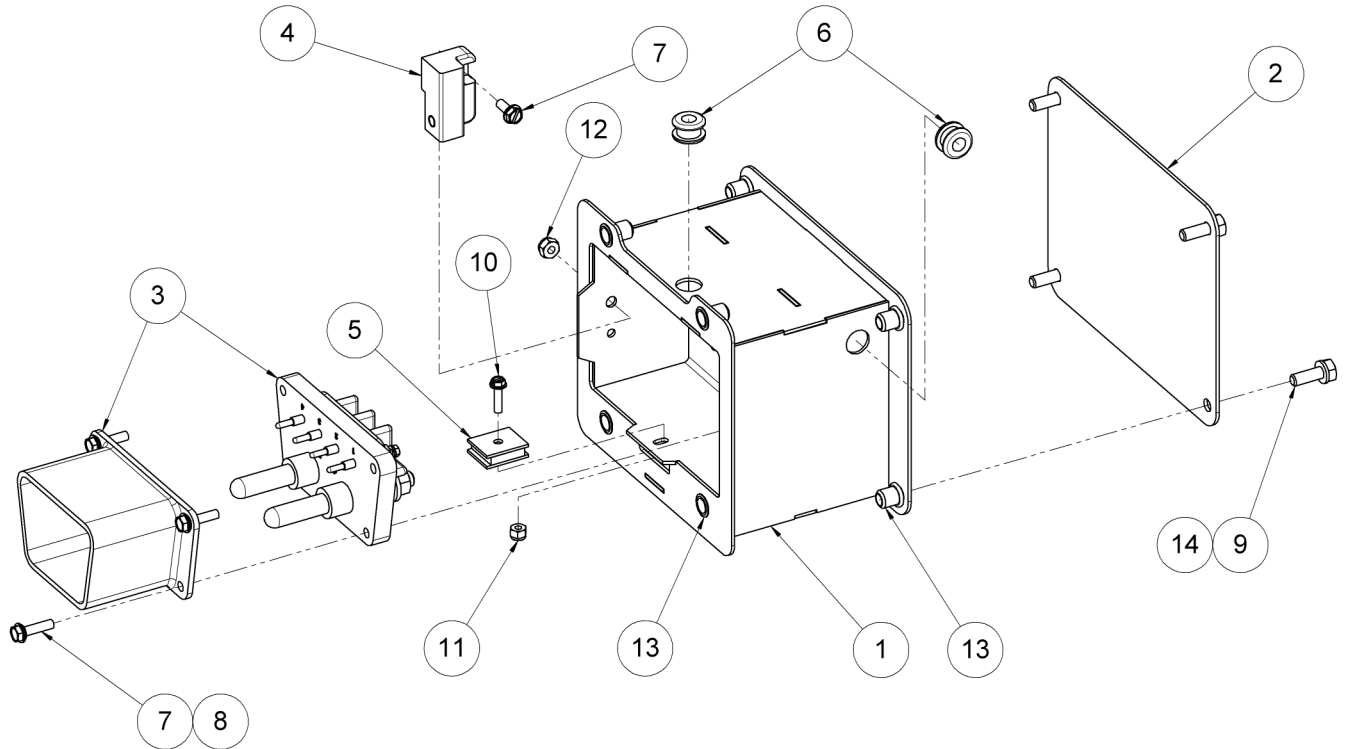

Item	Part Number	Qty.	Description
1	ET00-02-001-SA	1	CHARGE JACK WELDMENT
2	ET00-02-002-SA	1	CHARGE JACK REAR COVER
3	A-ES12-0442	1	BURTON CONNECTOR
4	82050000	1	PROXIMITY SENSOR BUZZLITE
5	ET00-24-001-CA	1	MAGNETIC LATCH
6	A-RTT12-00337	2	RUBBER GROMMET
7	NPN	5	HCS, #10-32 UNF X .75
8	NPN	4	LOCK WASHER, #10
9	NPN	4	HCS, 1/4-20 UNC X .75
10	NPN	1	HCS, #8-32 UNC X .625
11	NPN	1	LOCK NUT, #8-32 UNC
12	NPN	1	LOCK NUT, #10-32 UNF
13	NPN	8	RIVNUT, 1/4-20 UNC
14	NPN	4	LOCK WASHER, 1/4
N/A	DT04-2P	1	ELECTRICAL CONNECTOR (INSTALLED TO ITEM 4)
N/A	W2P	1	CONNECTOR LOCK (INSTALLED TO ITEM 4)
N/A	0460-215-16141	2	CONNECTOR PINS (INSTALLED TO ITEM 4)

Item 4 to be wired as shown below.

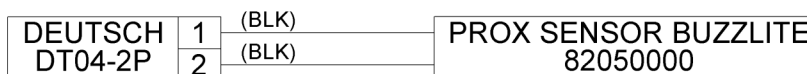

Dash Panel Subassembly

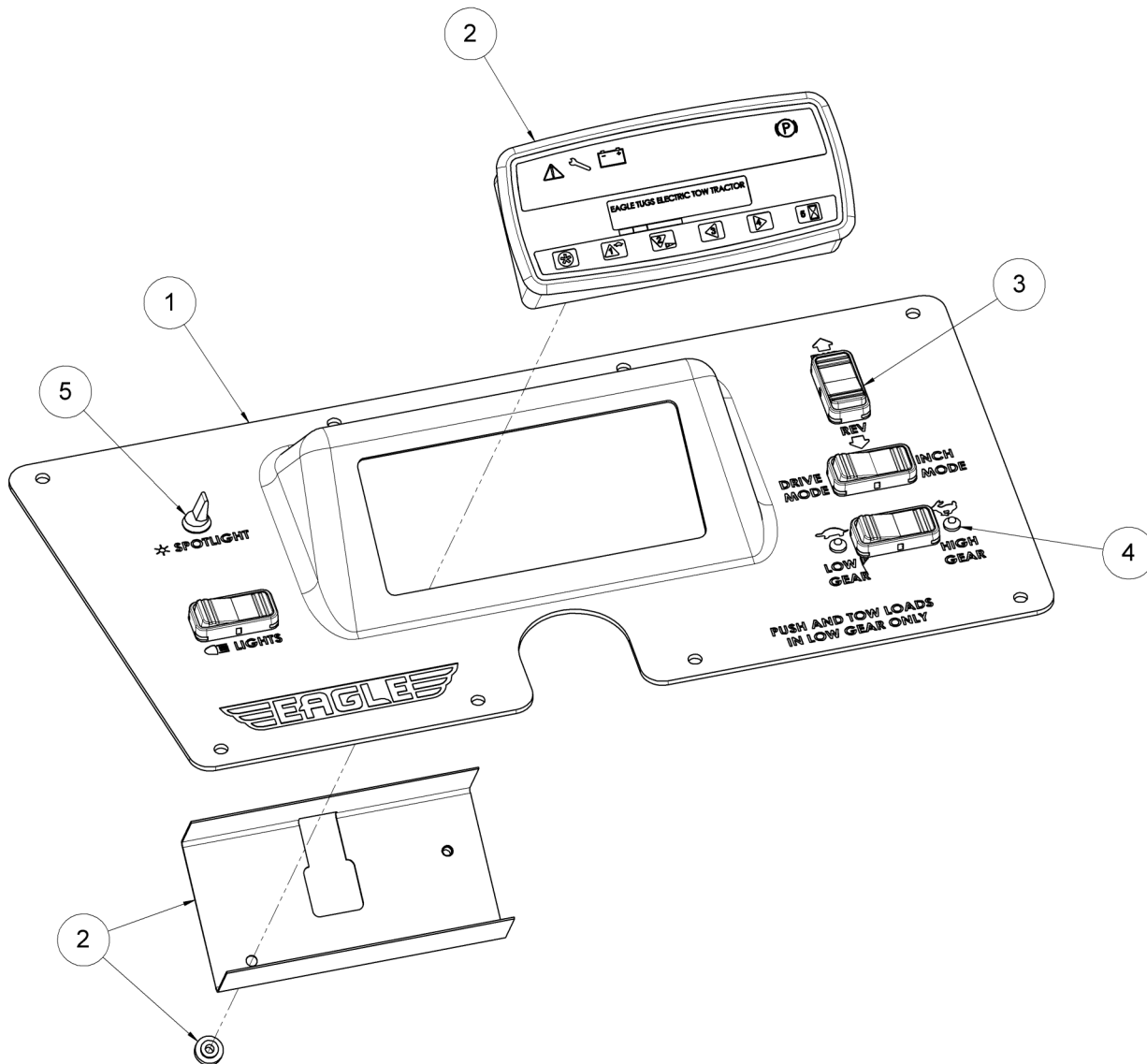

Item	Part Number	Qty.	Description
1	A-ES12-0800 REV 4	1	DASH PANEL
2	A-RTT-00415	1	DIGITAL DISPLAY PANEL (INCLUDES MOUNTING HARDWARE)
3	A-ES12-0801	4	ROCKER SWITCH
4	A-ES12-0804	2	LED INDICATOR LIGHT
5	A-TT4-00433-1	1	TOGGLE SWITCH

Dash Panel Subassembly

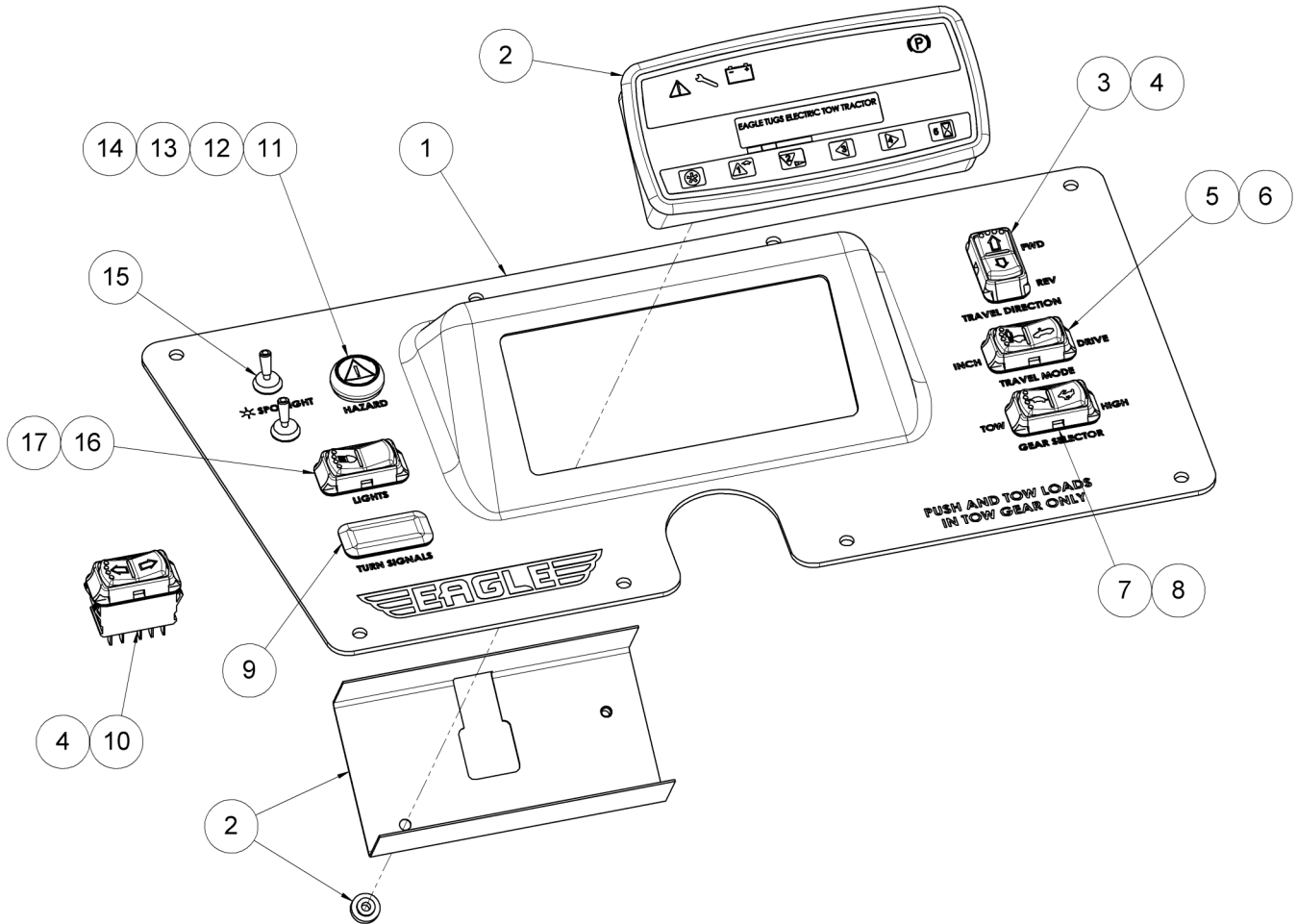

Item	Part Number	Qty.	Description
1	A-ES12-0800 REV 5	1	DASH PANEL
2	A-RTT-00415	1	DIGITAL DISPLAY PANEL (INCLUDES MOUNTING HARDWARE)
3	NVSP-14-001-CA	1	FWD/REV SWITCH BASE
4	NVSP-14-002-CA	2	FWD/REV AND TURN SIGNAL ACTUATOR (T/S OPTIONAL)
5	NVSP-14-001-CB	1	DRIVE/INCH SWITCH BASE
6	NVSP-14-002-CB	1	DRIVE/INCH SWITCH ACTUATOR
7	NVSP-14-001-CC	1	HIGH/LOW SWITCH BASE
8	NVSP-14-002-CC	1	HIGH/LOW SWITCH ACTUATOR
9	NVSP-14-003-CA	1	EMPTY SWITCH PLUG
10	NVSP-14-001-CE	1	TURN SIGNAL SWITCH BASE (OPTIONAL)
11	NVSP-14-004-CA	1	HAZARD PUSHBUTTON
12	NVSP-14-005-CA	1	HAZARD PUSHBUTTON LENS
13	NVSP-14-006-CA	1	HAZARD BACKLIGHT
14	NVSP-14-007-CA	1	HAZARD CONTACT BLOCK
15	NVSP-14-008-CA	1-2	LIT TIP TOGGLE SWITCH (OPTIONAL)
16	NVSP-14-001-CD	1	HEADLIGHT SWITCH BASE
17	NVSP-14-002-CD	1	HEADLIGHT SWITCH ACTUATOR
N/A	ET00-05-002-SA	1	DASH HARNESS

Power Distribution Box

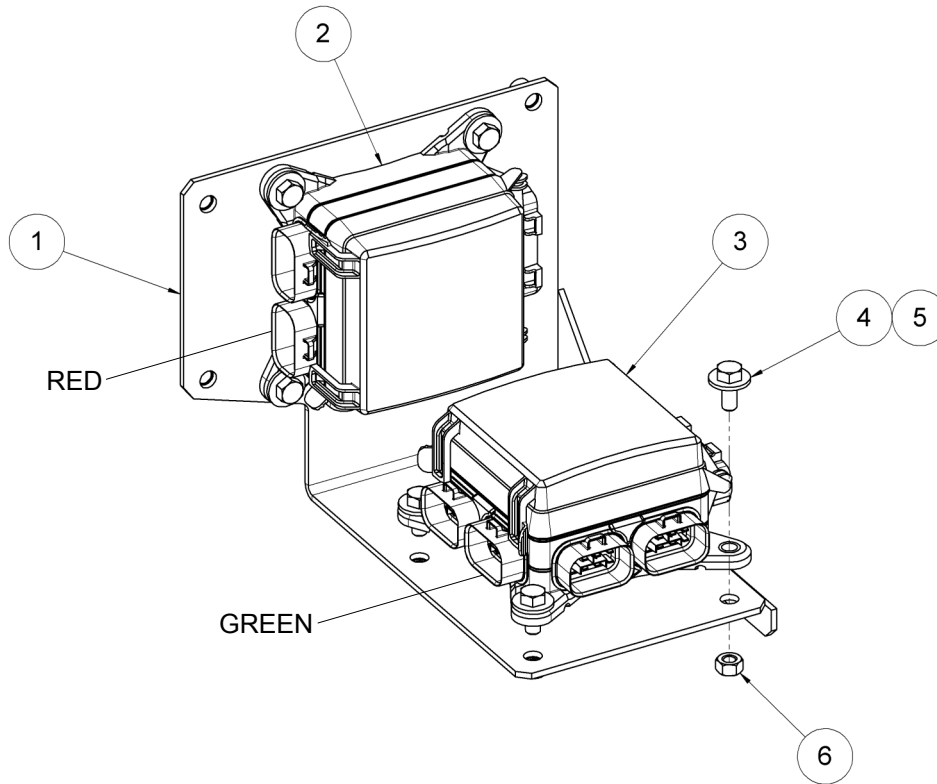

Item	Part Number	Qty.	Description
1	A-ES12-0101	1	POWER DISTRIBUTION MOUNTING BRACKET
2	A-ES12-0412-1R	1	POWER DISTRIBUTION BOX A
3	A-ES12-0412-1L	1	POWER DISTRIBUTION BOX B
4	NPN	8	HCS, 5/16-18 UNC X .75
5	NPN	8	FLAT WASHER, 5/16
6	NPN	8	LOCK NUT, 5/16-18 UNC

Power Distribution Box Layout

Item	Part Number	Description
F1	NPN	MINI FUSE, 30 AMP
F2	NPN	MINI FUSE, 30 AMP
F3	NPN	MINI FUSE, 10 AMP
F4	NPN	MINI FUSE, 5 AMP
F5	NPN	MINI FUSE, 5 AMP
F6	NPN	MINI FUSE, 25 AMP
F7	NPN	MINI FUSE, 5 AMP
F8	NPN	MINI FUSE, 5 AMP
F9	NPN	MINI FUSE, 5 AMP
R1	ET00-81-001-CA	12V, 35A MICRO RELAY
R2	ET00-81-001-CA	12V, 35A MICRO RELAY
R3	ET00-81-002-CA	FLASHER

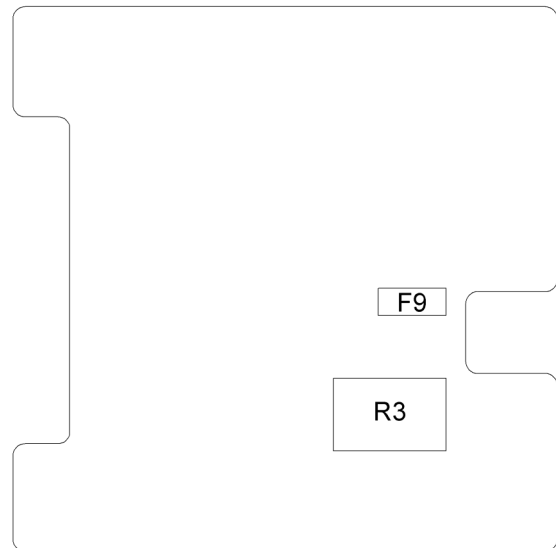
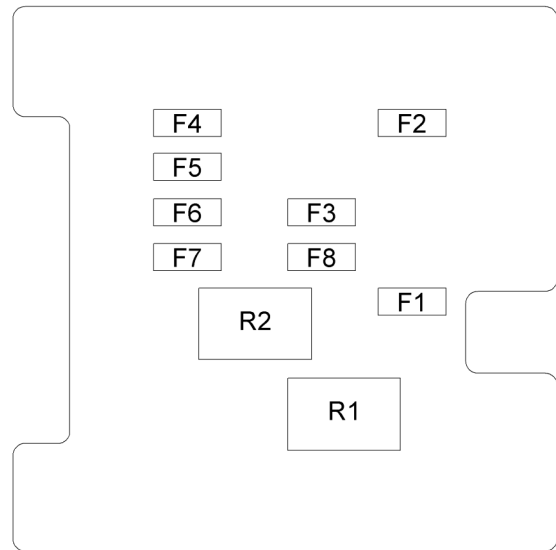

Power Distribution Box

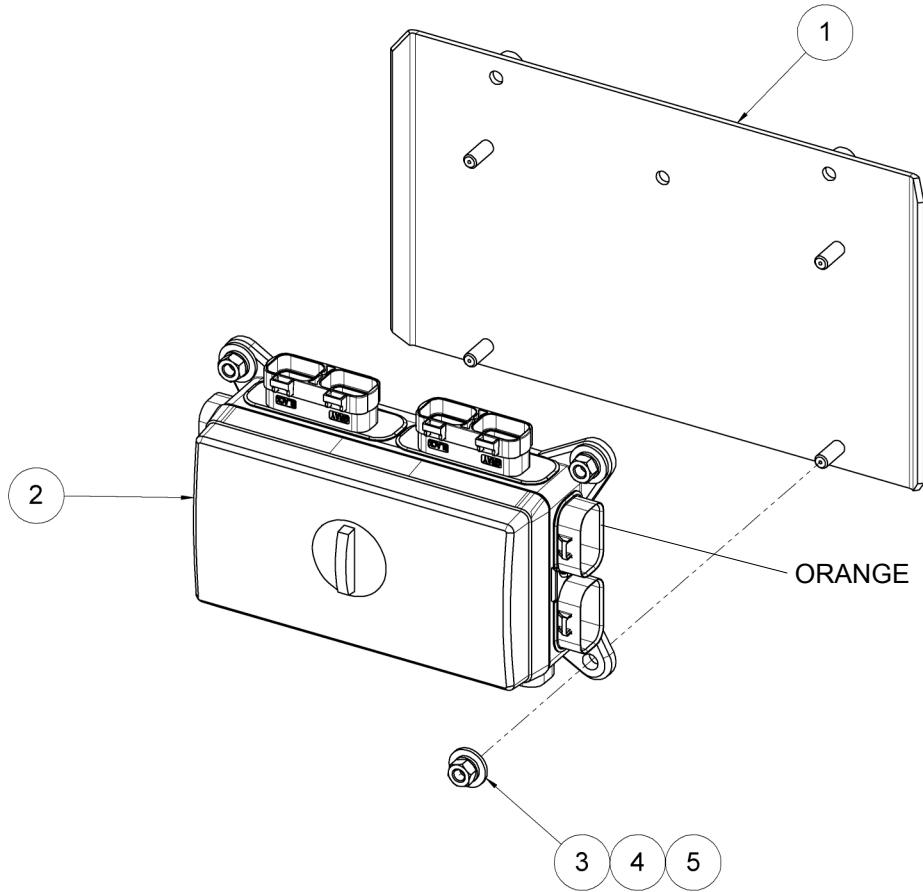

Item	Part Number	Qty.	Description
1	A-ES12-0202	1	POWER DISTRIBUTION MOUNTING BRACKET
2	ET00-05-001-SA	1	POWER DISTRIBUTION BOX
3	NPN	4	FLAT WASHER, 5/16
4	NPN	4	LOCK WASHER, 5/16
5	NPN	4	HEX NUT, 5/16-18 UNC

Power Distribution Box

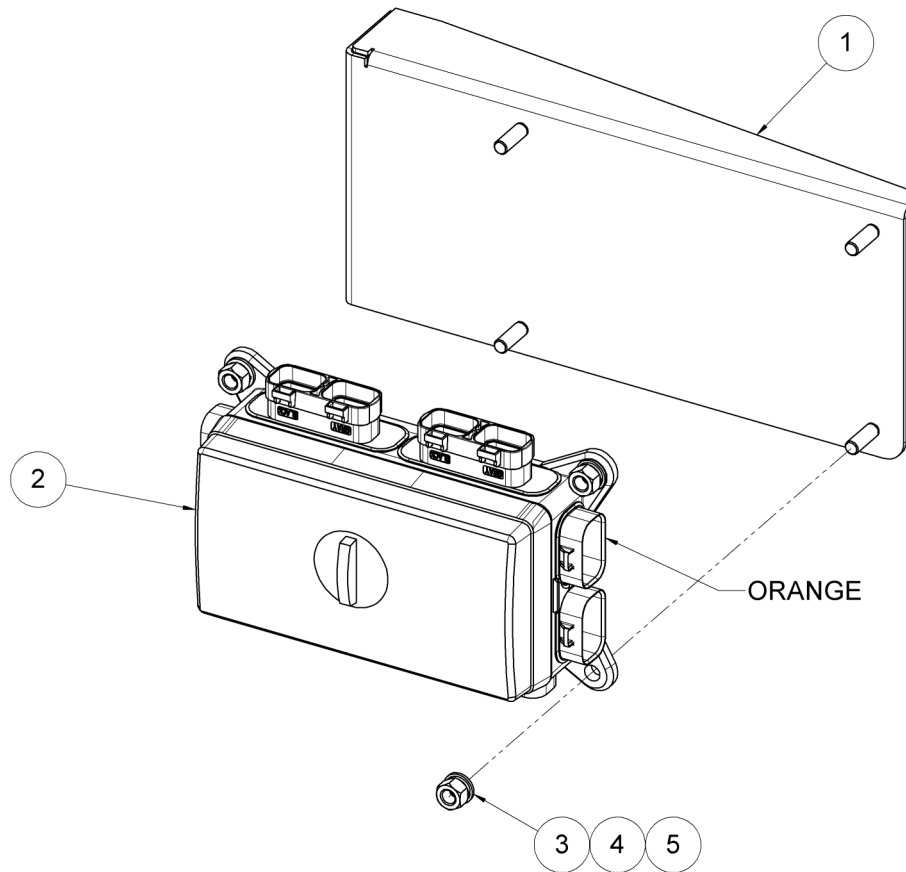

Item	Part Number	Qty.	Description
1	ET12-02-005-SA	1	POWER DISTRIBUTION MOUNTING BRACKET
2	ET00-05-001-SA	1	POWER DISTRIBUTION BOX
3	NPN	4	FLAT WASHER, 5/16
4	NPN	4	LOCK WASHER, 5/16
5	NPN	4	HEX NUT, 5/16-18 UNC

Power Distribution Box Layout

Item	Part Number	Description
F1	NPN	MINI FUSE, 5 AMP
F2	NPN	MINI FUSE, 10 AMP
F3	NPN	MINI FUSE, 2 AMP
F4	NPN	MINI FUSE, 2 AMP
F5	NPN	MINI FUSE, 5 AMP
F6	NPN	MINI FUSE, 5 AMP
F7	NPN	MINI FUSE, 30 AMP
F8	NPN	MINI FUSE, 2 AMP
F9	NPN	MINI FUSE, 2 AMP
F10	NPN	MINI FUSE, 7.5 AMP
F11	NPN	MINI FUSE, 2 AMP
F12	NPN	MINI FUSE, 5 AMP
F13	NPN	MINI FUSE, 2 AMP
F14	NPN	MINI FUSE, 5 AMP
F15	NPN	MINI FUSE, 5 AMP
F16	N/A	EMPTY
R1	ET00-81-001-CA	12V, 35A MICRO RELAY
R2	ET00-81-001-CA	12V, 35A MICRO RELAY
R3	ET00-81-001-CA	12V, 35A MICRO RELAY
R4	ET00-81-001-CA	12V, 35A MICRO RELAY
RS1	ET00-81-003-CA	2KΩ RESISTOR

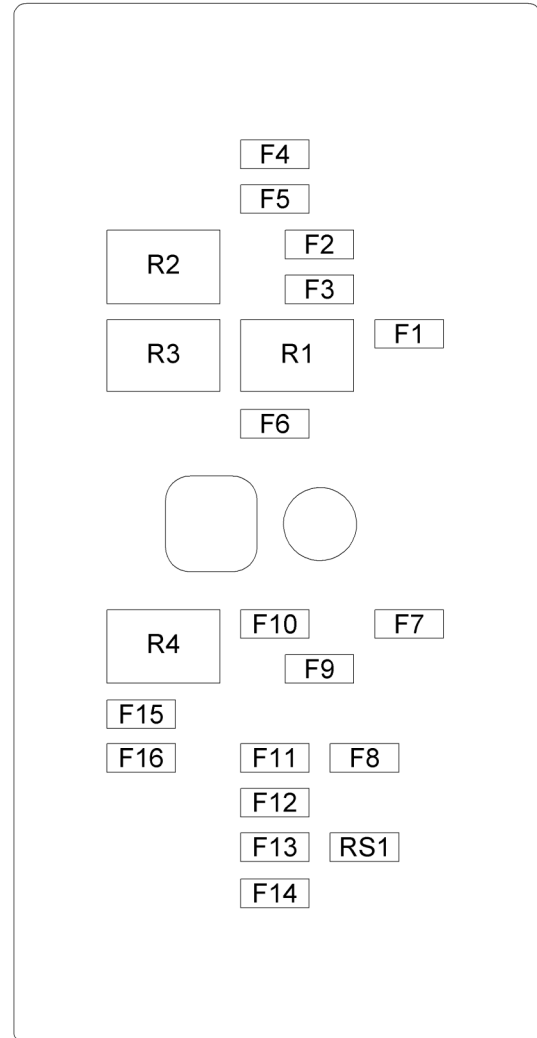

This page intentionally left blank.

Revision Log

Rev	Date	Description	Appr.
A	20-Feb-2014	Original release for production	PRB
B	27-Mar-2014	Changed F15 fuse size in power distribution box	SEB
C	04-Sep-2014	Added part numbers for headlight switch	SEB
D	20-Jan-2015	Added RevG power distribution bracket	PRB
E	29-Apr-2015	Application serial number range updated to reflect production sequencing	SEB
F	18-Feb-2016	Added flexible bus bars	PRB
G	6-Jun-2016	Changed eXL16 model name to eTT16	TFP
H	28-Jul-2016	Added new charge jack assembly	TFP

Table of Contents

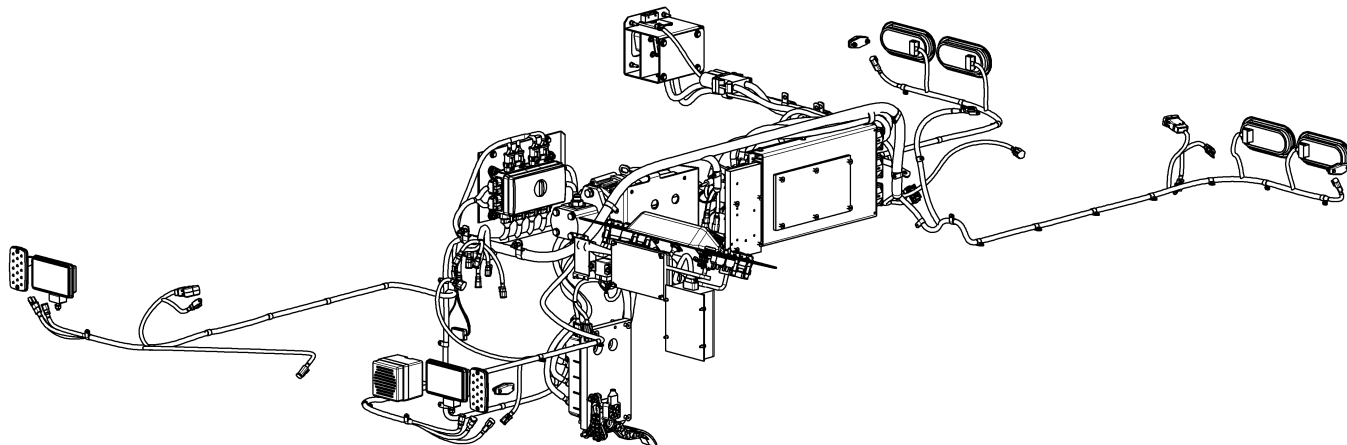

Section 5 - Electrical System

Description	Page
Front Lighting	5-2
Rear Lighting	5-6
Power Distribution Box	5-8
Throttle Pedal, Key Switch	5-11
Center Bulkhead Drive Components	5-12
DC-DC Converters, Vehicle Controller, Relay	5-14
Horn	5-15
Charge Jack	5-16
Inching Switches	5-18
Battery Cable Schematic	5-19
Battery Cables - Hydraulic Pump Drive	5-25
Battery Cables - Traction Drive	5-28
Battery Cables - Battery Connector	5-30
Battery Cables - Charge Jack	5-32
Vehicle Harness - Front	5-34
Vehicle Harness - Manifold Block Connections	5-36
Vehicle Harness - Power Distribution	5-38
Vehicle Harness - Traction and Pump Drives	5-41
Vehicle Harness - Rear	5-42
Vehicle Harness - Under Dash	5-44
Battery Installation	5-45
Revision Log	5-46

Front Lighting

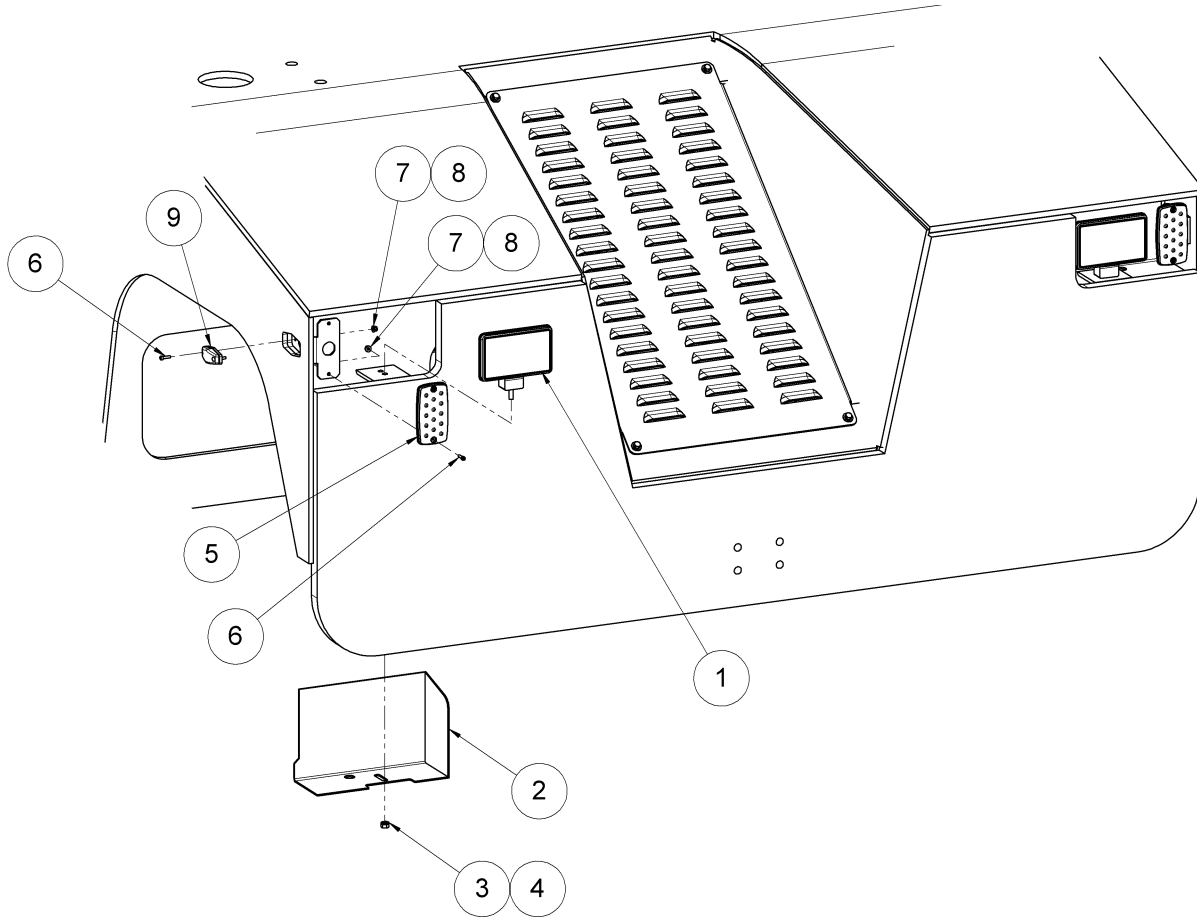

Front Lighting

Item	Part Number	Qty.	Description
1	A-ES12-0492	2	HEADLIGHT
2	A-ES12-0111-A	1	HEADLIGHT BAFFLE WELDMENT, RH
N/A	A-ES12-0111-B	1	HEADLIGHT BAFFLE WELDMENT, LH
3	NPN	2	LOCK WASHER, 5/16 (PART OF ITEM 2)
4	NPN	2	NUT, 5/16-18 UNC (PART OF ITEM 2)
5	NVSP-34-006-CA	2	TURN INDICATOR, AMBER
6	NPN	8	SHCS, #8-32 UNC X .625, SS
7	NPN	8	FLAT WASHER, #8
8	NPN	8	LOCK NUT, NYLON INSERT, #8-32 UNC, SS
9	A-EXL16-0490-1	2	SIDE INDICATOR LIGHT, AMBER
N/A	DT04-2P	2	ELECTRICAL CONNECTOR (INSTALLED TO ITEM 1)
N/A	W2P	2	CONNECTOR LOCK (INSTALLED TO ITEM 1)
N/A	0460-215-16141	4	CONNECTOR PINS (INSTALLED TO ITEM 1)
N/A	DT04-3P	2	ELECTRICAL CONNECTOR (INSTALLED TO ITEM 5)
N/A	W3P	2	CONNECTOR LOCK (INSTALLED TO ITEM 5)
N/A	0460-215-16141	6	CONNECTOR PINS (INSTALLED TO ITEM 5)
N/A	DT06-2S	4	ELECTRICAL CONNECTOR (INSTALLED TO ITEM 9)
N/A	W2S	4	CONNECTOR LOCK (INSTALLED TO ITEM 9)
N/A	0462-209-16141	8	CONNECTOR SOCKETS (INSTALLED TO ITEM 9)

Item 1 to be wired as shown below.



Item 5 to be wired as shown below.



Item 9 to be wired as shown below.

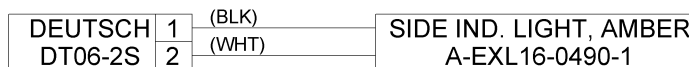

Front Lighting

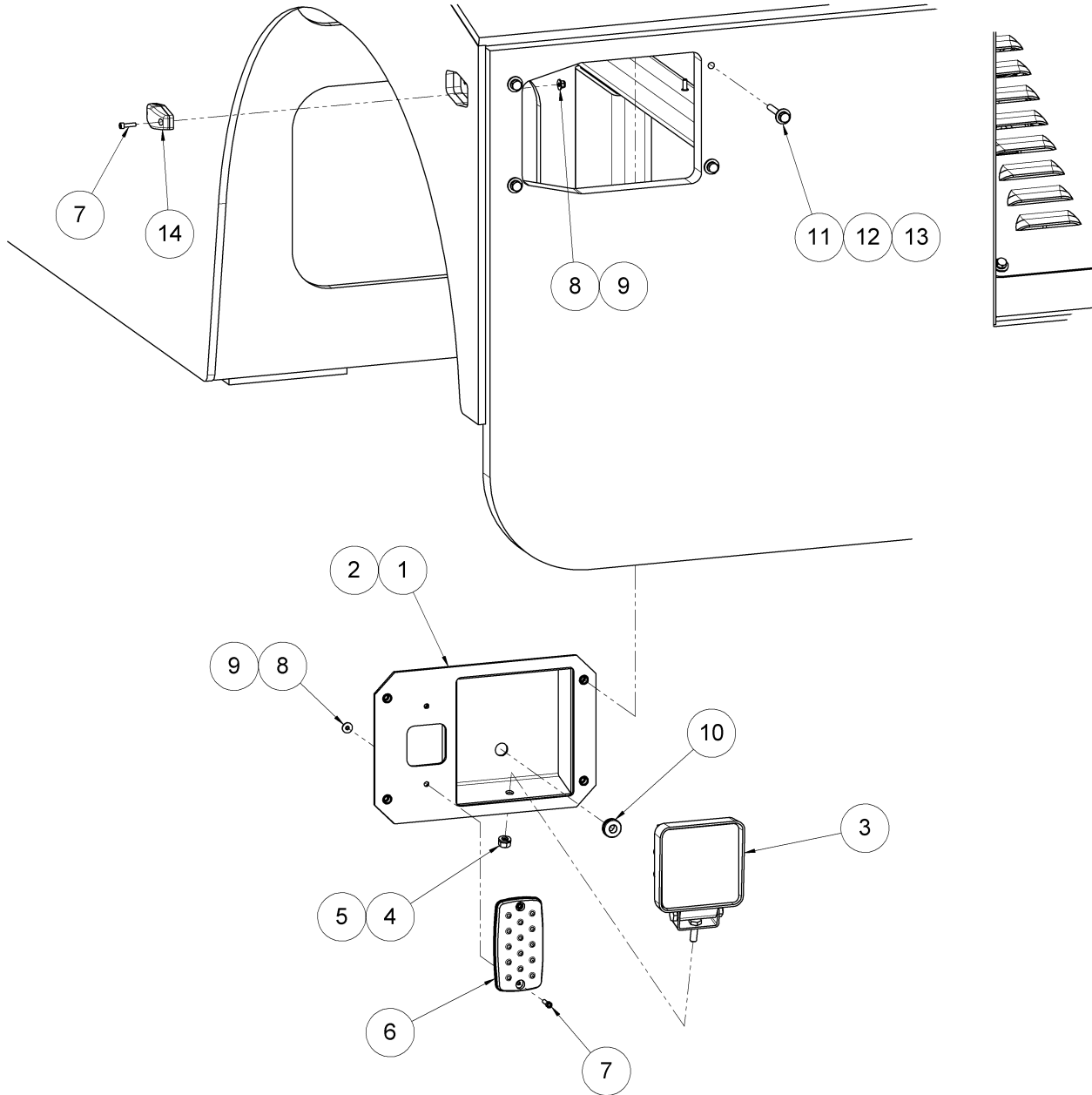

Front Lighting

Item	Part Number	Qty.	Description
1	ET12-02-001-SB	1	HEADLIGHT POCKET WELDMENT, RH
N/A	ET12-02-001-SA	1	HEADLIGHT POCKET WELDMENT, LH
2	NPN	8	RIVET NUTS, 1/4-20 UNC, OPEN ENDED, .135 GRIP
3	NVSP-34-007-CA	2	HEADLIGHT, LED, SQUARE 500 LUMEN
4	NPN	2	LOCK WASHER (PART OF ITEM 3)
5	NPN	2	NUT (PART OF ITEM 3)
6	NVSP-34-006-CA	2	TURN INDICATOR, AMBER
7	NPN	8	SHCS, #8-32 UNC X .625, SS
8	NPN	8	FLAT WASHER, #8
9	NPN	8	LOCK NUT, NYLON INSERT, #8-32 UNC, SS
10	AE-OPT-0320-E	2	SILICONE GROMMET, 3/8"
11	NPN	8	HCS, 1/4-20 UNC X 2.0
12	NPN	8	LOCK WASHER, 1/4
13	NPN	8	FLAT WASHER, 1/4
14	A-EXL16-0490-1	2	SIDE INDICATOR LIGHT, AMBER
N/A	DT04-2P	2	ELECTRICAL CONNECTOR (INSTALLED TO ITEM 3)
N/A	W2P	2	CONNECTOR LOCK (INSTALLED TO ITEM 3)
N/A	0460-215-16141	4	CONNECTOR PINS (INSTALLED TO ITEM 3)
N/A	DT04-3P	2	ELECTRICAL CONNECTOR (INSTALLED TO ITEM 6)
N/A	W3P	2	CONNECTOR LOCK (INSTALLED TO ITEM 6)
N/A	0460-215-16141	6	CONNECTOR PINS (INSTALLED TO ITEM 6)
N/A	DT06-2S	4	ELECTRICAL CONNECTOR (INSTALLED TO ITEM 14)
N/A	W2S	4	CONNECTOR LOCK (INSTALLED TO ITEM 14)
N/A	0462-209-16141	8	CONNECTOR SOCKETS (INSTALLED TO ITEM 14)

Item 3 to be wired as shown below.



Item 6 to be wired as shown below.



Item 14 to be wired as shown below.

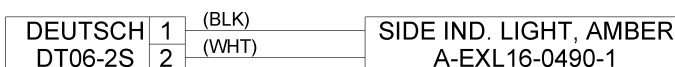

Rear Lighting

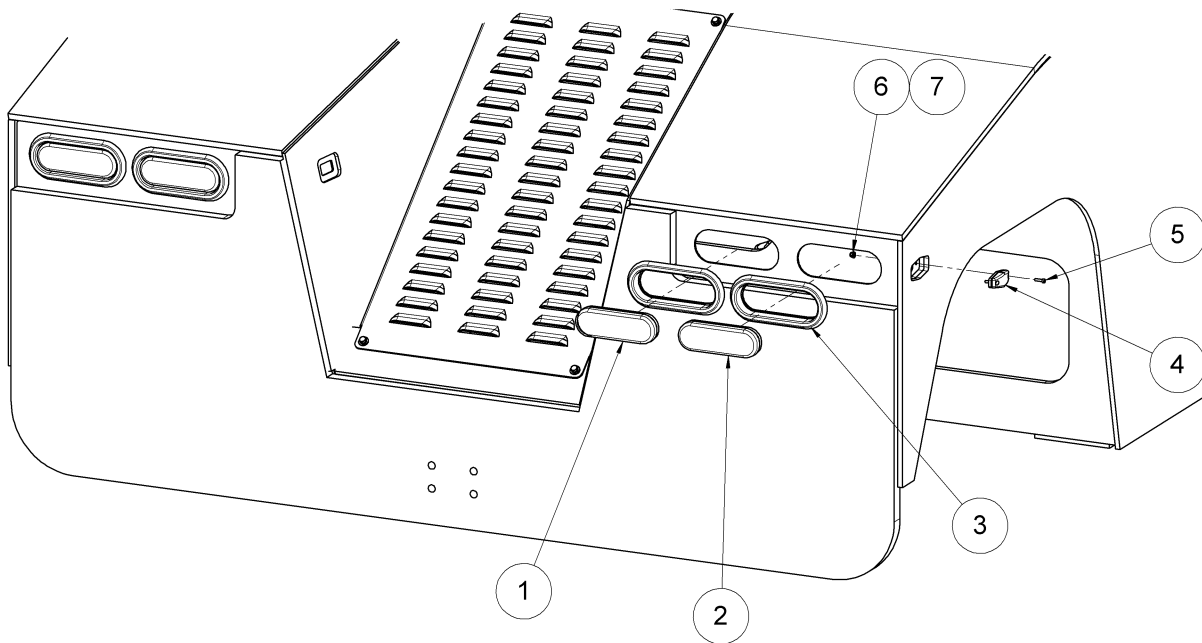

Item	Part Number	Qty.	Description
1	A-ES12-0494	2	REVERSE LAMP
2	A-RTT12E-00292	2	STOP LAMP
3	A-RTT12E-00287	4	LIGHT GROMMET
4	NVSP-34-001-CA	2	SIDE INDICATOR LIGHT, RED
5	NPN	4	SHCS, #8-32 UNC X .625, SS
6	NPN	4	FLAT WASHER, #8
7	NPN	4	LOCK NUT, NYLON INSERT, #8-32 UNC, SS
N/A	DT06-2S	2	ELECTRICAL CONNECTOR (INSTALLED TO ITEM 4)
N/A	W2S	2	CONNECTOR LOCK (INSTALLED TO ITEM 4)
N/A	0462-209-16141	4	CONNECTOR SOCKETS (INSTALLED TO ITEM 4)

Item 4 to be wired as shown below.



Rear Lighting

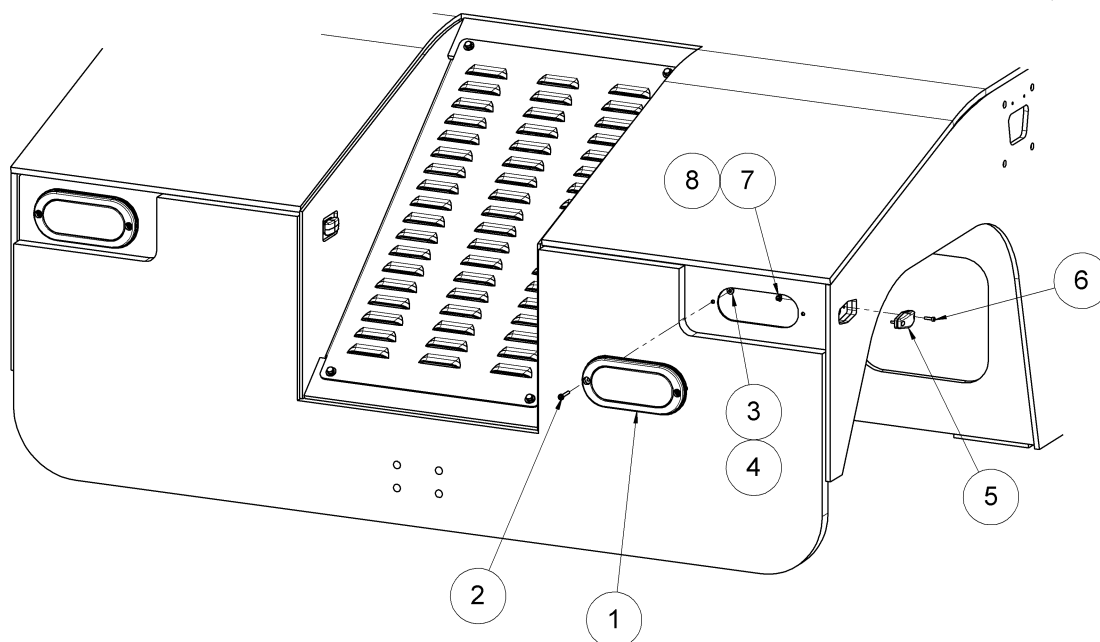

Item	Part Number	Qty.	Description
1	A-MTT5-0491	2	TAIL LIGHT
2	NPN	4	HCS, #10-32 UNF X 1.25
3	A-EXL16-0490-1	4	FLAT WASHER, #10
4	A-RTT12E-00292	4	LOCK NUT, #10-32
5	NVSP-34-001-CA	2	SIDE INDICATOR LIGHT, RED
6	NPN	4	SHCS, #8-32 UNC X .625, SS
7	NPN	4	FLAT WASHER, #8
8	NPN	4	LOCK NUT, NYLON INSERT, #8-32 UNC, SS
N/A	DT06-2S	2	ELECTRICAL CONNECTOR (INSTALLED TO ITEM 5)
N/A	W2S	2	CONNECTOR LOCK (INSTALLED TO ITEM 5)
N/A	0462-209-16141	4	CONNECTOR SOCKETS (INSTALLED TO ITEM 5)

Item 5 to be wired as shown below.



Power Distribution Box

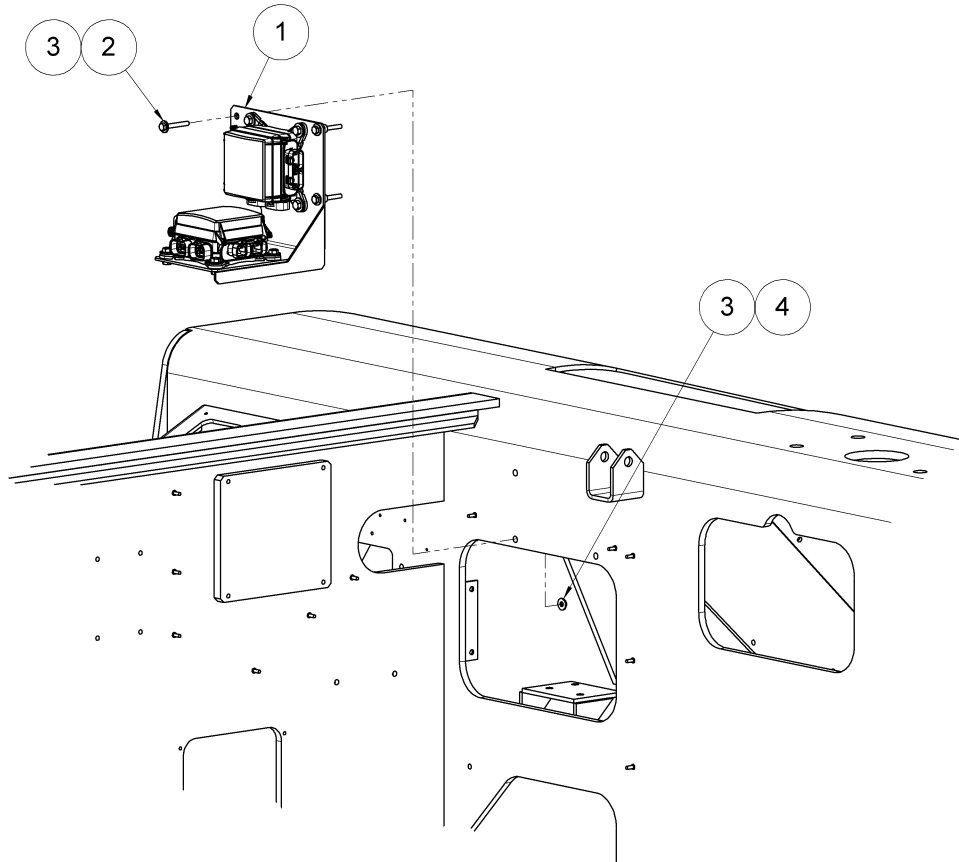

Item	Part Number	Qty.	Description
1	NPN	1	POWER DISTRIBUTION SUBASSEMBLY (SEE SECTION 4)
2	NPN	4	HCS, 1/4-20 UNC X 2.00
3	NPN	8	FLAT WASHER, 1/4
4	NPN	4	LOCK NUT, 1/4-20 UNC

Power Distribution Box

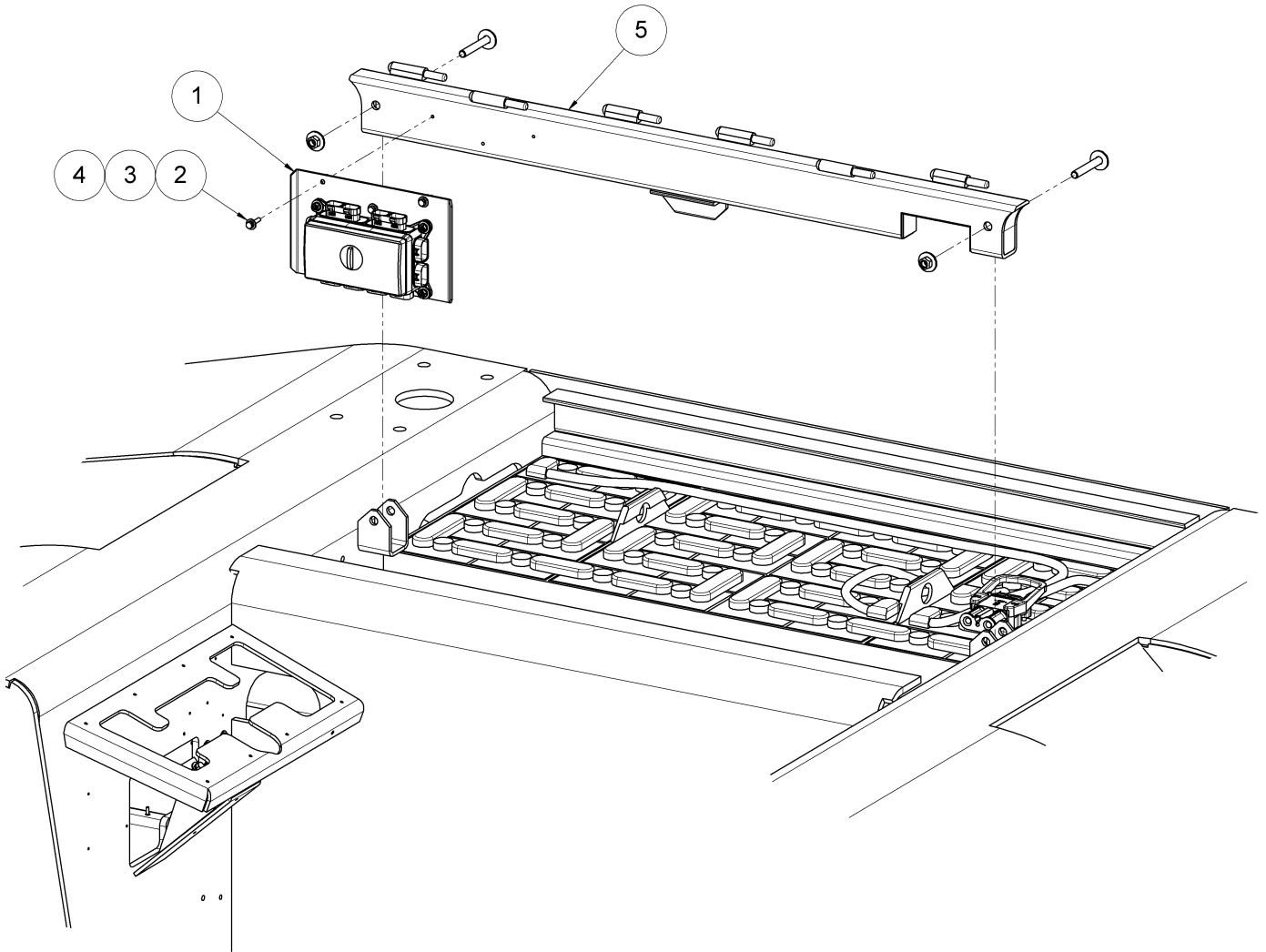

Item	Part Number	Qty.	Description
1	NPN	1	POWER DISTRIBUTION SUBASSEMBLY (SEE SECTION 4)
2	NPN	3	HCS, 1/4-20 UNC X 1.25
3	NPN	3	LOCK WASHER, 1/4
4	NPN	3	FLAT WASHER, 1/4
5	N/A	1	PANEL SUPPORT WELDMENT (SEE SECTION 8)

Power Distribution Box

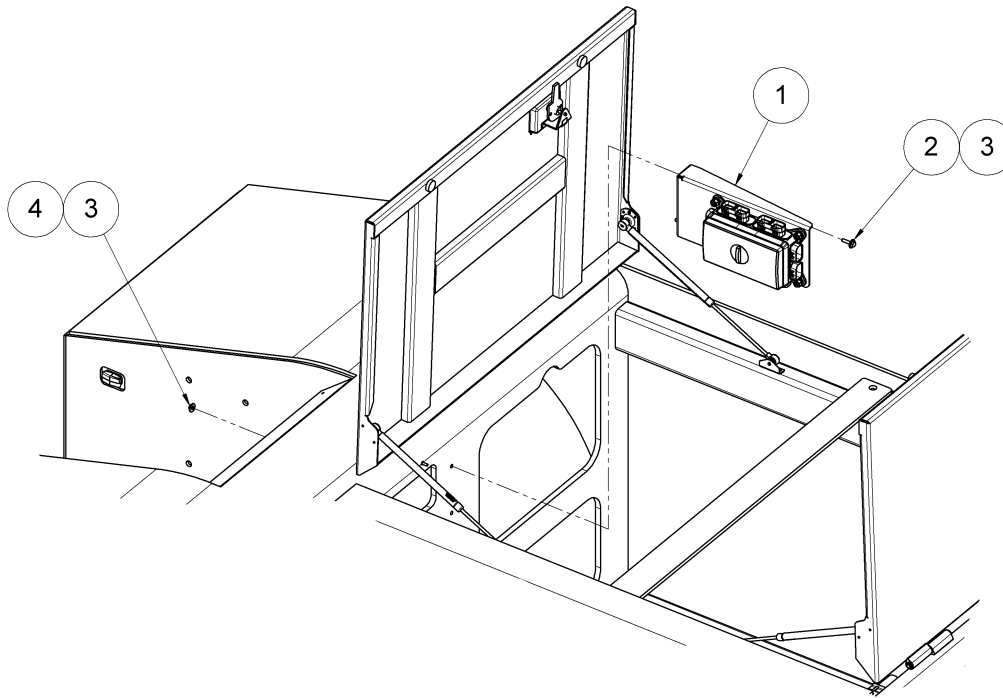

Item	Part Number	Qty.	Description
1	NPN	1	POWER DISTRIBUTION/FUSE BOX ASSEMBLY (SEE SECTION 4)
2	NPN	2	HCS, 1/4-20 UNC X 1.0
3	NPN	4	FLAT WASHER, 1/4
4	NPN	2	LOCK NUT, 1/4-20 UNC

Throttle Pedal and Key Switch

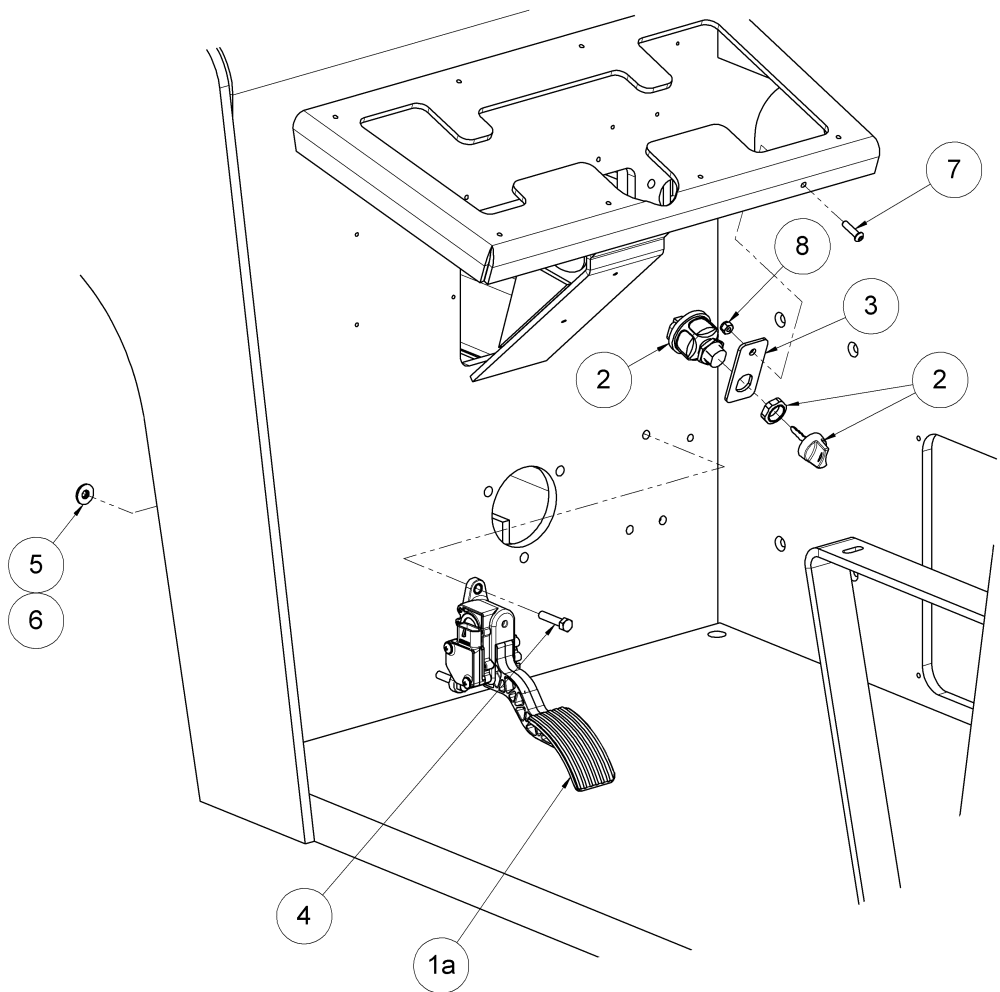
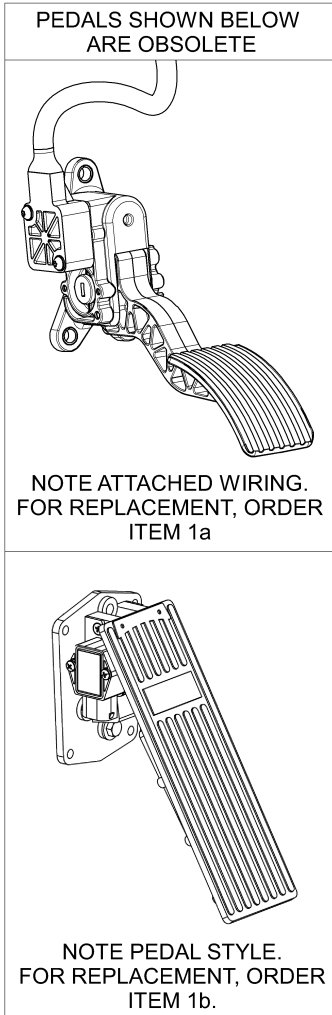

Item	Part Number	Qty.	Description
1a	NVSP-14-028-KA	1	THROTTLE PEDAL, DUAL ANALOG (INCLUDES ADAPTOR HARNESS)
1b	NVSP-14-032-KA	-	THROTTLE PEDAL, DUAL ANALOG (INCLUDES ADAPTOR HARNESS)
	NVSP-05-005-CA	1	IGNITION SWITCH
N/A	NVSP-05-005-CB	1	IGNITION SWITCH (KEYLESS OPTION)
	NVSP-14-025-SA	1	KEY SWITCH BRACKET
	NPN	3	HCS, 5/16-18 UNC X 1.25
	NPN	3	FLAT WASHER, 5/16
	NPN	3	LOCK NUT, 5/16-18 UNC
	NPN	1	BHS, 1/4-20 UNC X 1, SS
	NPN	1	LOCK NUT, NYLON INSERT, 1/4-20 UNC, SS

Center Bulkhead Drive Components

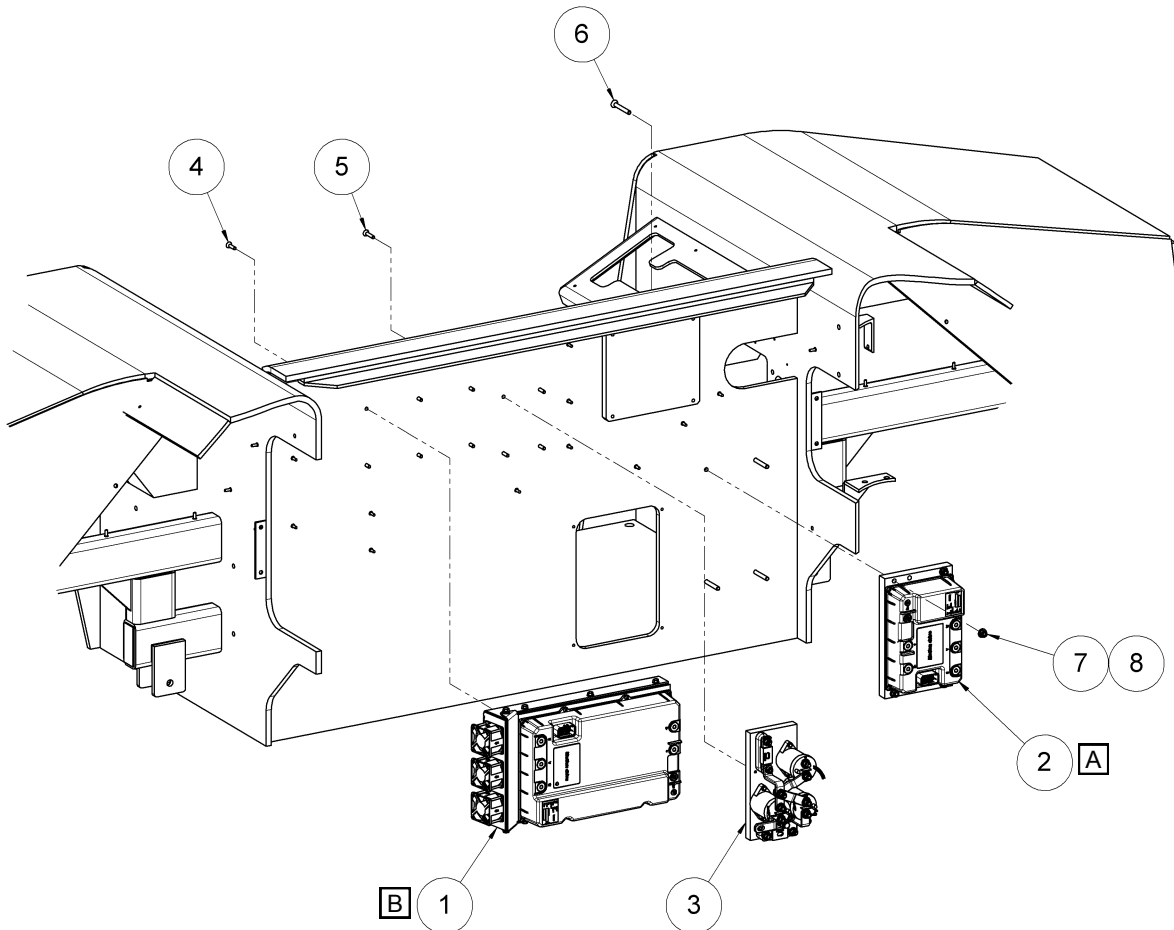

A Apply 1/4 fl oz. (15 grams) of Dow Corning® 340 Heat Sink Compound or equivalent to the surface of item 2. The thermal compound should be applied evenly over the entire mating surface.

B If flat traction drive assembly (without finned heatsink) is installed, apply 1/2 fl oz. (30 grams) of Dow Corning® 340 Heat Sink Compound or equivalent to the surface of item 1. The thermal compound should be applied evenly over the entire mating surface.

Item	Part Number	Qty.	Description
1	NPN	1	TRACTION DRIVE ASSEMBLY (SEE SECTION 4)
2	A-EXL16-0560	1	PUMP MOTOR DRIVE
3	NPN	1	CONTACTOR ASSEMBLY (SEE SECTION 4)
4	NPN	6	FHS, 1/4-20 UNC X 1, SS
5	NPN	4	FHS, 1/4-20 UNC X 1.25, SS
6	NPN	4	FHS, 5/16-18 UNC X 2.5, SS
7	NPN	4	FLAT WASHER, 5/16, SS
8	NPN	4	LOCK NUT, NYLON INSERT, 5/16-18 UNC, SS

Center Bulkhead Drive Components

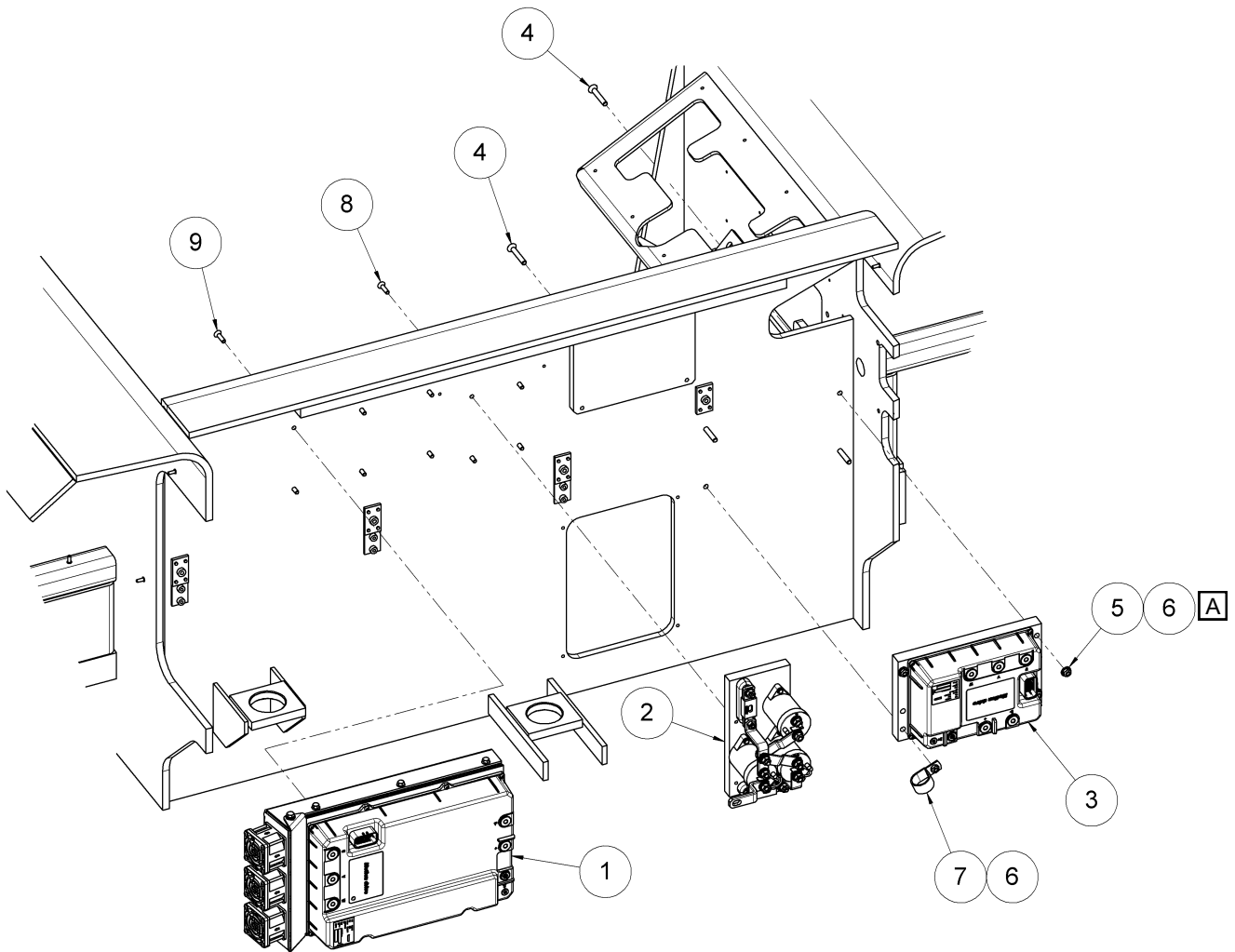

A Apply 1/4 fl oz. (15 grams) of Dow Corning® 340 Heat Sink Compound or equivalent to the surface of item 2. The thermal compound should be applied evenly over the entire mating surface.

Item	Part Number	Qty.	Description
1	NPN	1	TRACTION DRIVE ASSEMBLY (SEE SECTION 4)
2	NPN	1	CONTACTOR ASSEMBLY (SEE SECTION 4)
3	A-EXL16-0560	1	PUMP MOTOR DRIVE
4	NPN	4	FHS, 5/16-18 UNC X 2.5, SS
5	NPN	3	FLAT WASHER, 5/16, SS
6	NPN	1	LOCK NUT, NYLON INSERT, 5/16-18 UNC, SS
7	NPN	1	CUSHIONED BAND CLAMP
8	NPN	6	FHS, 1/4-20 UNC X 1.25, SS
9	NPN	4	FHS, 1/4-20 UNC X 1.0, SS

DC-DC Converters, Vehicle Controller, Relay

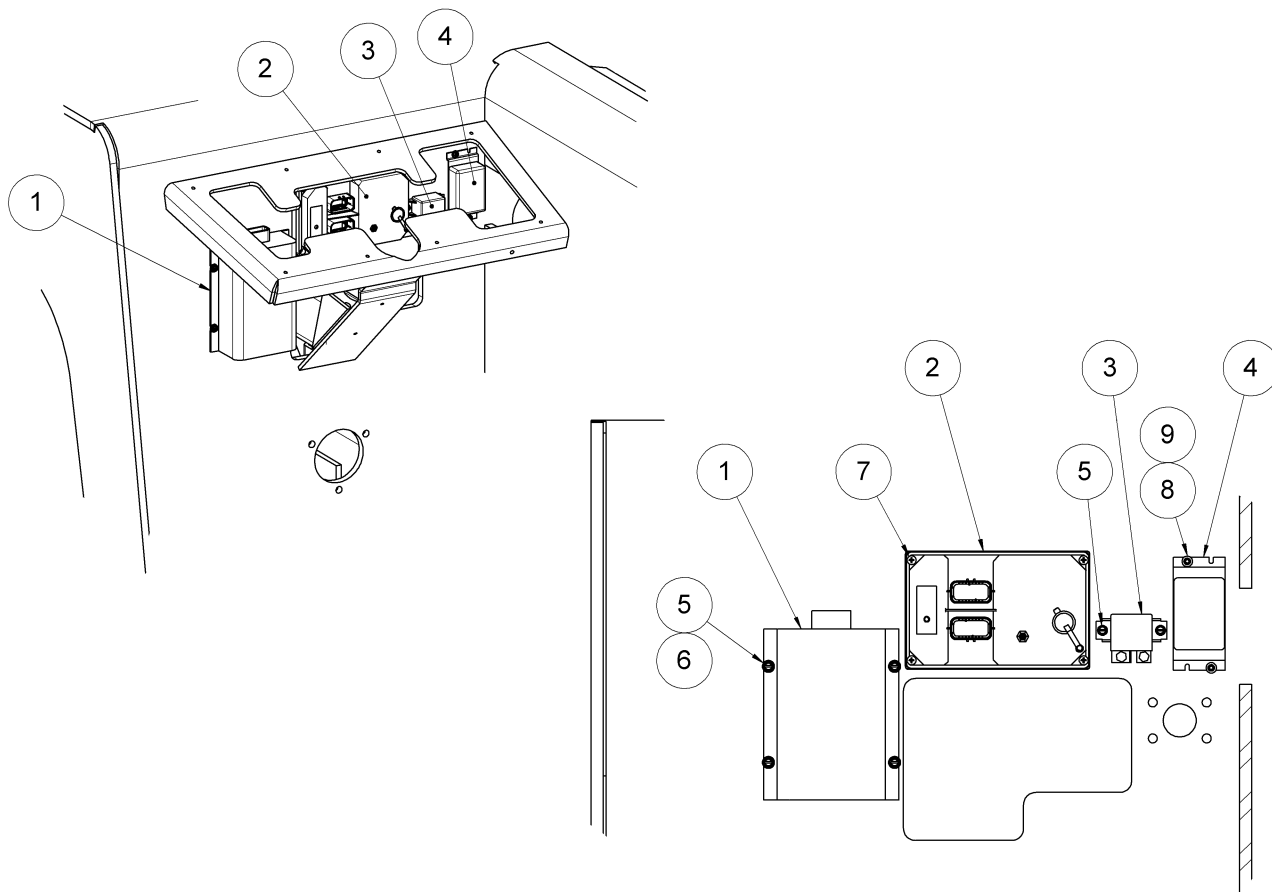

Item	Part Number	Qty.	Description
1	A-ES12-0414	1	12V DC-DC CONVERTER
2	A-ES12-0424	1	VEHICLE MASTER CONTROLLER
3	7A5012	1	ACS RELAY
4	A-ES12-0413	1	5V DC-DC CONVERTER
5	NPN	6	HCS, #10-32 UNF X .5
6	NPN	4	FLAT WASHER, #10
7	NPN	4	PHS, #10-32 UNF X .75
8	NPN	2	SHCS, #8-32 UNC X .625
9	NPN	2	FLAT WASHER, #8
N/A	DT04-4P	1	ELECTRICAL CONNECTOR (INSTALLED TO ITEM 4)
N/A	W4P	1	CONNECTOR LOCK (INSTALLED TO ITEM 4)
N/A	0460-215-16141	4	CONNECTOR PINS (INSTALLED TO ITEM 4)

Item 4 to be wired as shown below.

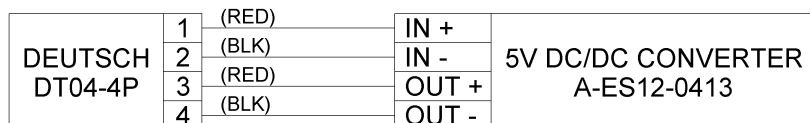

Horn

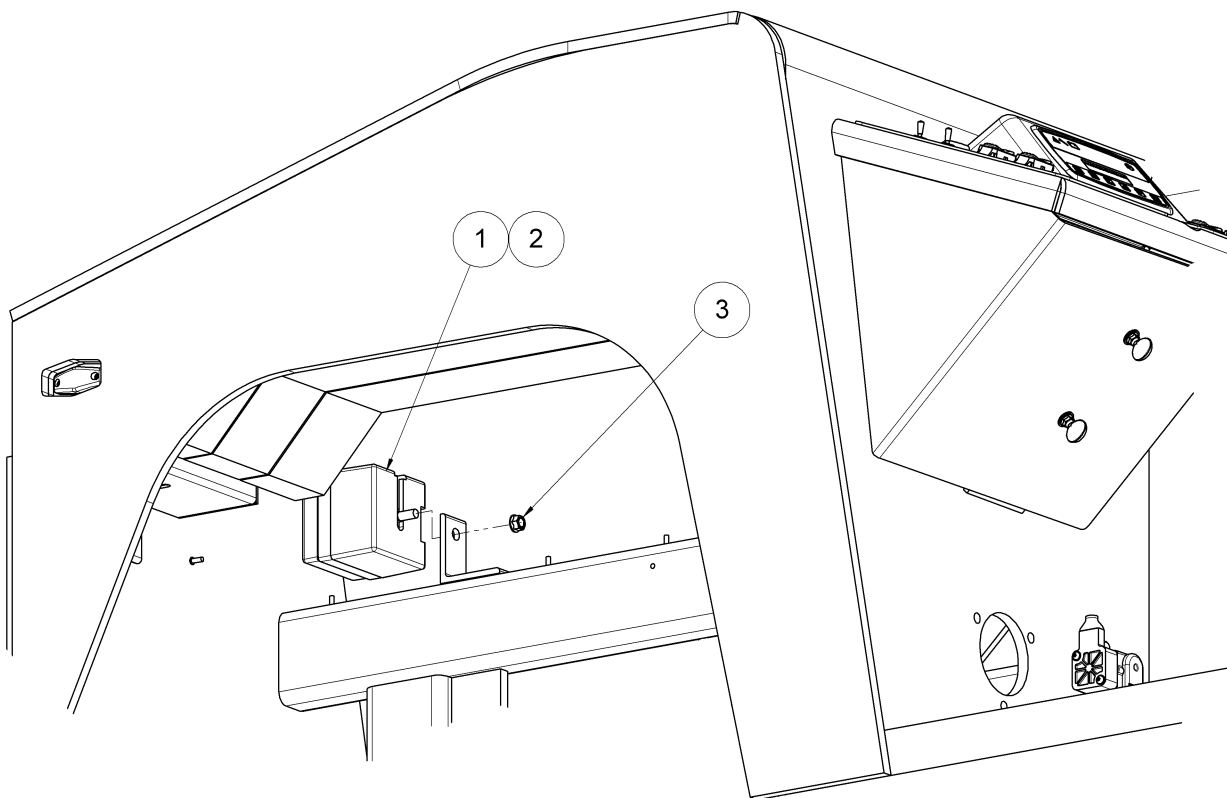

Item	Part Number	Qty.	Description
1	A-RTT12-00052	1	HORN
2	NPN	1	CARRIAGE BOLT, 3/8-16 UNC X 1 (INCLUDED WITH ITEM 1)
3	NPN	1	FLANGE NUT, 3/8-16 UNC (INCLUDED WITH ITEM 1)

Charge Jack

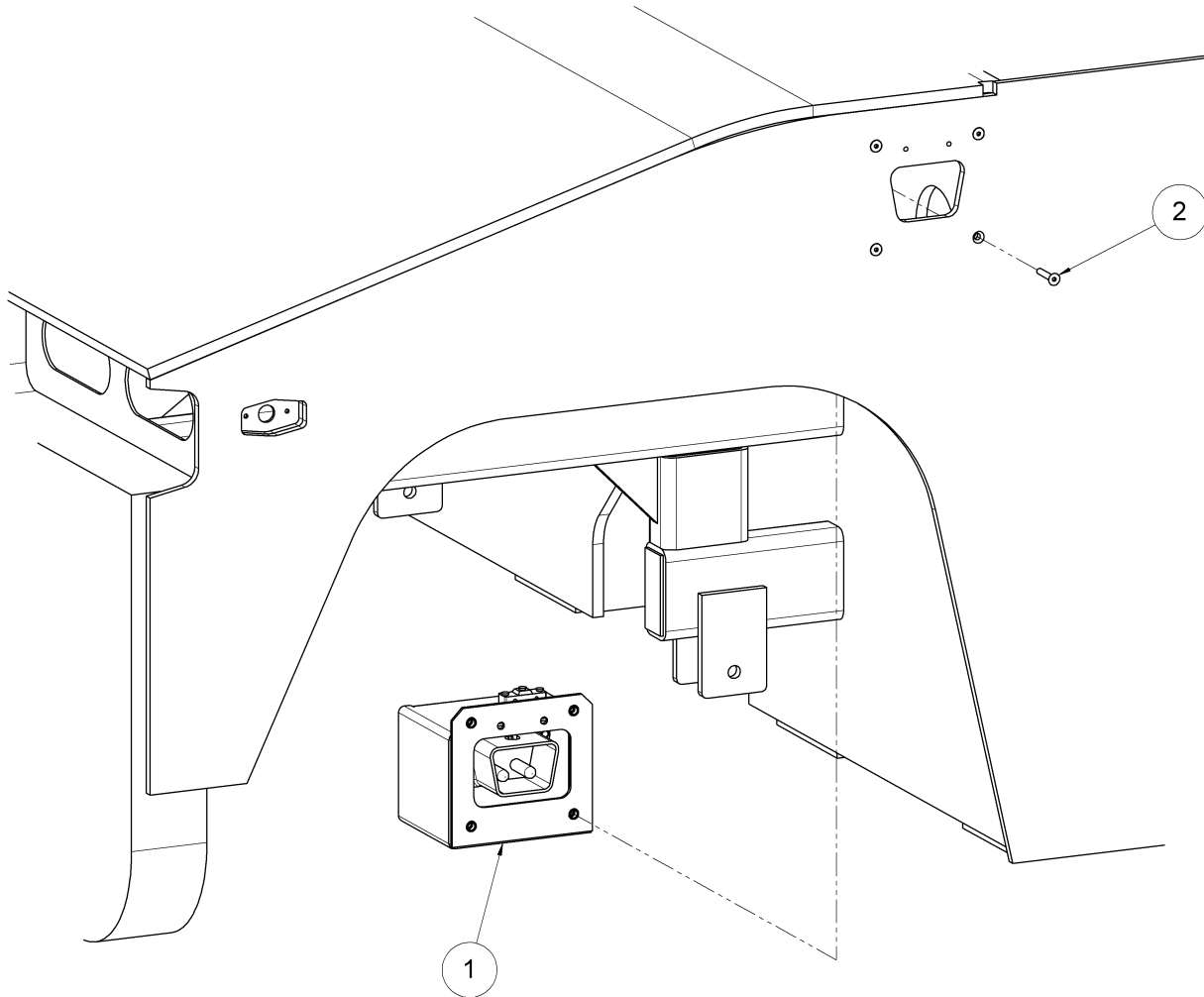

Item	Part Number	Qty.	Description
1	NPN	1	CHARGE JACK ASSEMBLY (SEE SECTION 4)
2	NPN	4	FHS, 1/4-20 UNC X 1.5, SS

Charge Jack

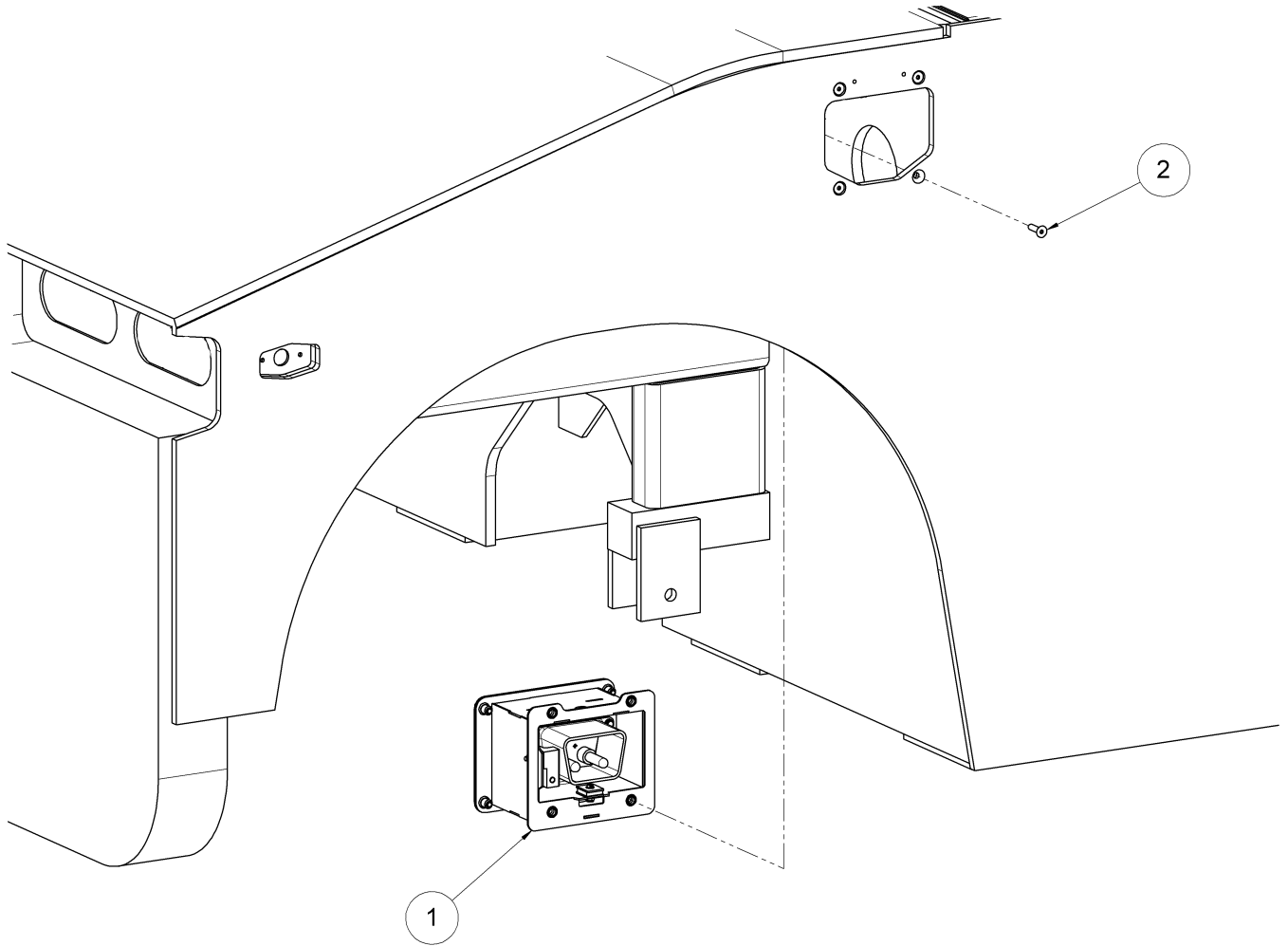

Item	Part Number	Qty.	Description
1	NPN	1	CHARGE JACK ASSEMBLY (SEE SECTION 4)
2	NPN	4	FHS, 1/4-20 UNC X 1, SS

Inching Switches

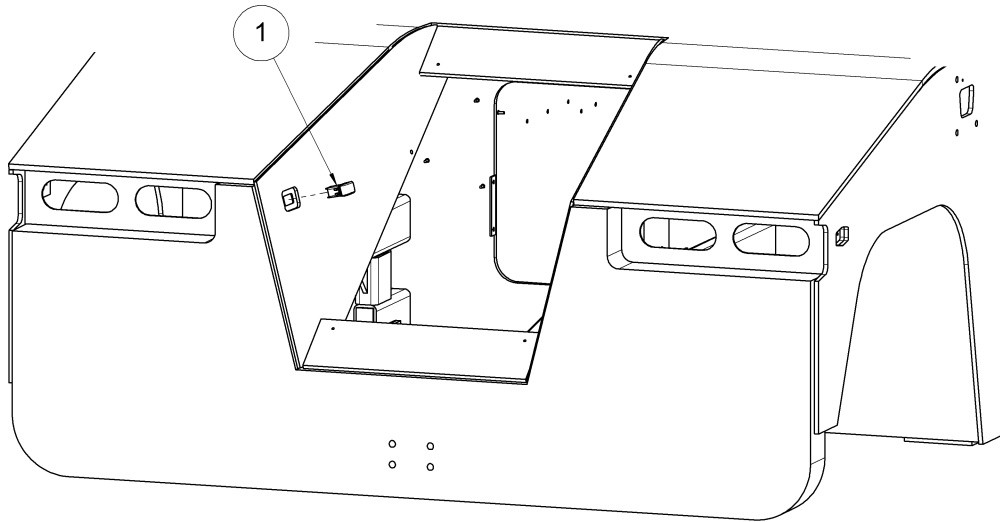

Item	Part Number	Qty.	Description
1	ET00-14-001-CA	2	INCHING SWITCH (WITH ETCHED ARROWS)
1	A-ES12-0803	2	INCHING SWITCH (SOLID BLACK)

Note: Inching switches must be replaced with like kind. For solid black switch only, replace dielectric grease in electrical connections on inching switch every 6 months to prevent moisture from getting inside switch.

Battery Cable Schematic

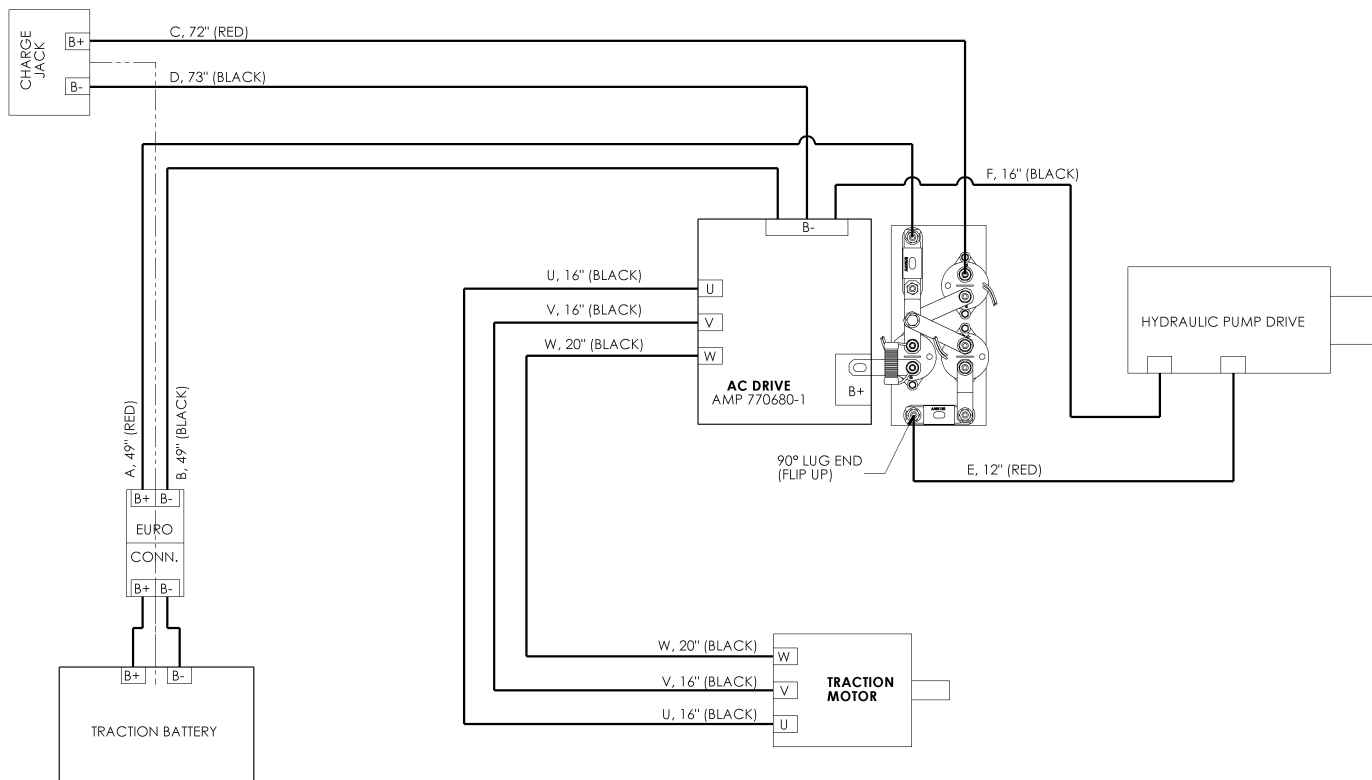

ITEM	WIRE				END A		END B	
	GAGE	COLOR	P/N	LENGTH	P/N	TYPE	P/N	TYPE
A	2/0	RED	A-ES12-0498	49"	A-ES12-0447	EURO	A-ES12-0497	STRAIGHT
B	2/0	BLACK	A-ES12-0499	49"			A-ES12-0497	STRAIGHT
C	2/0	RED	A-ES12-0498	72"	A-ES12-0497	STRAIGHT	A-ES12-0497	STRAIGHT
D	2/0	BLACK	A-ES12-0499	73"	A-ES12-0497	STRAIGHT	A-ES12-0497	STRAIGHT
E	2/0	RED	A-ES12-0498	12"	A-ES12-0497	STRAIGHT	A-ES12-0501	90°
F	2/0	BLACK	A-ES12-0499	16"	A-ES12-0497	STRAIGHT	A-ES12-0497	STRAIGHT
U	2/0	BLACK	A-ES12-0499	16"	A-ES12-0497	STRAIGHT	A-ES12-0497	STRAIGHT
V	2/0	BLACK	A-ES12-0499	16"	A-ES12-0497	STRAIGHT	A-ES12-0497	STRAIGHT
W	2/0	BLACK	A-ES12-0499	20"	A-ES12-0497	STRAIGHT	A-ES12-0497	STRAIGHT

Battery Cable Schematic

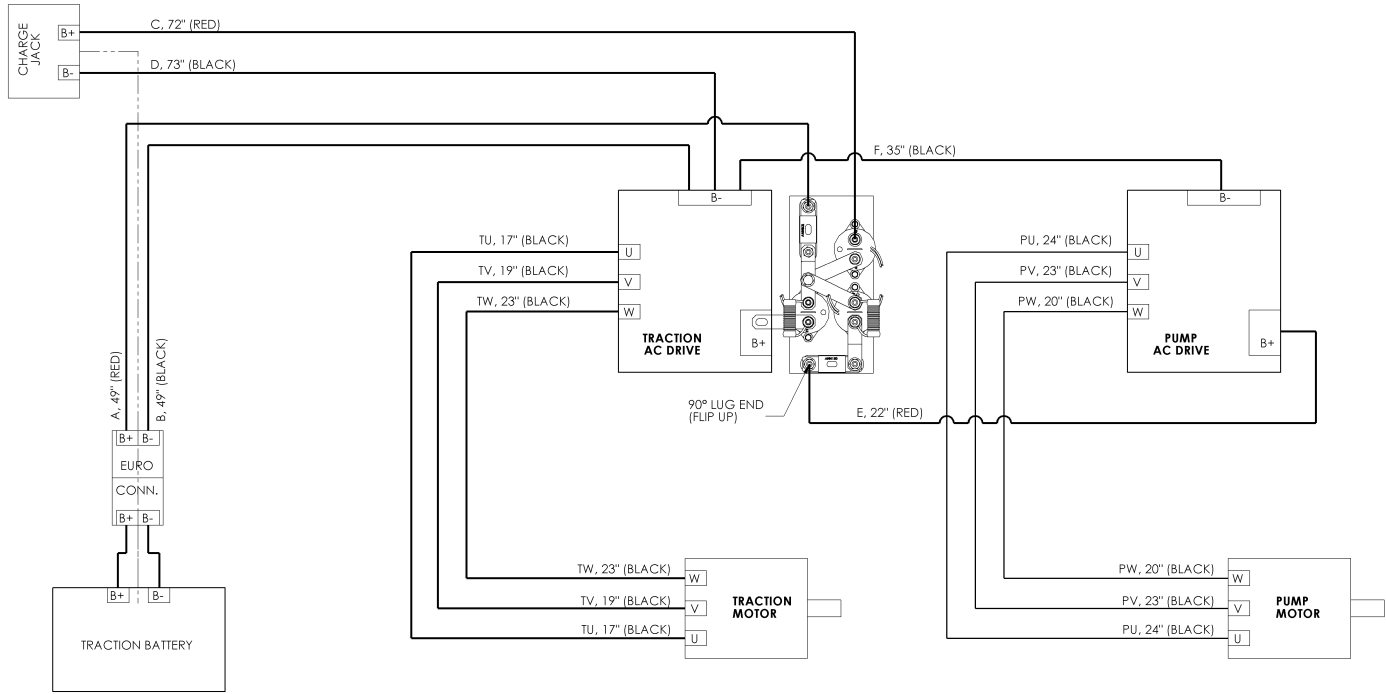

ITEM	WIRE				END A		END B	
	GAGE	COLOR	P/N	LENGTH	P/N	TYPE	P/N	TYPE
A	2/0	RED	A-ES12-0498	49"	A-ES12-0447	EURO	A-ES12-0497	STRAIGHT
B	2/0	BLACK	A-ES12-0499	49"	A-ES12-0497	STRAIGHT	A-ES12-0497	STRAIGHT
C	2/0	RED	A-ES12-0498	72"	A-ES12-0497	STRAIGHT	A-ES12-0497	STRAIGHT
D	2/0	BLACK	A-ES12-0499	73"	A-ES12-0497	STRAIGHT	A-ES12-0497	STRAIGHT
E	2/0	RED	A-ES12-0498	22"	A-ES12-0497	STRAIGHT	A-ES12-0501	90°
F	2/0	BLACK	A-ES12-0499	35"	A-ES12-0497	STRAIGHT	A-ES12-0497	STRAIGHT
PU	1/0	BLACK	A-ES12-0502	24"	A-ES12-0503	STRAIGHT	A-ES12-0503	STRAIGHT
PV	1/0	BLACK	A-ES12-0502	23"	A-ES12-0503	STRAIGHT	A-ES12-0503	STRAIGHT
PW	1/0	BLACK	A-ES12-0502	20"	A-ES12-0503	STRAIGHT	A-ES12-0503	STRAIGHT
TU	2/0	BLACK	A-ES12-0499	17"	A-ES12-0497	STRAIGHT	A-ES12-0497	STRAIGHT
TV	2/0	BLACK	A-ES12-0499	19"	A-ES12-0497	STRAIGHT	A-ES12-0497	STRAIGHT
TW	2/0	BLACK	A-ES12-0499	23"	A-ES12-0497	STRAIGHT	A-ES12-0497	STRAIGHT

Battery Cable Schematic

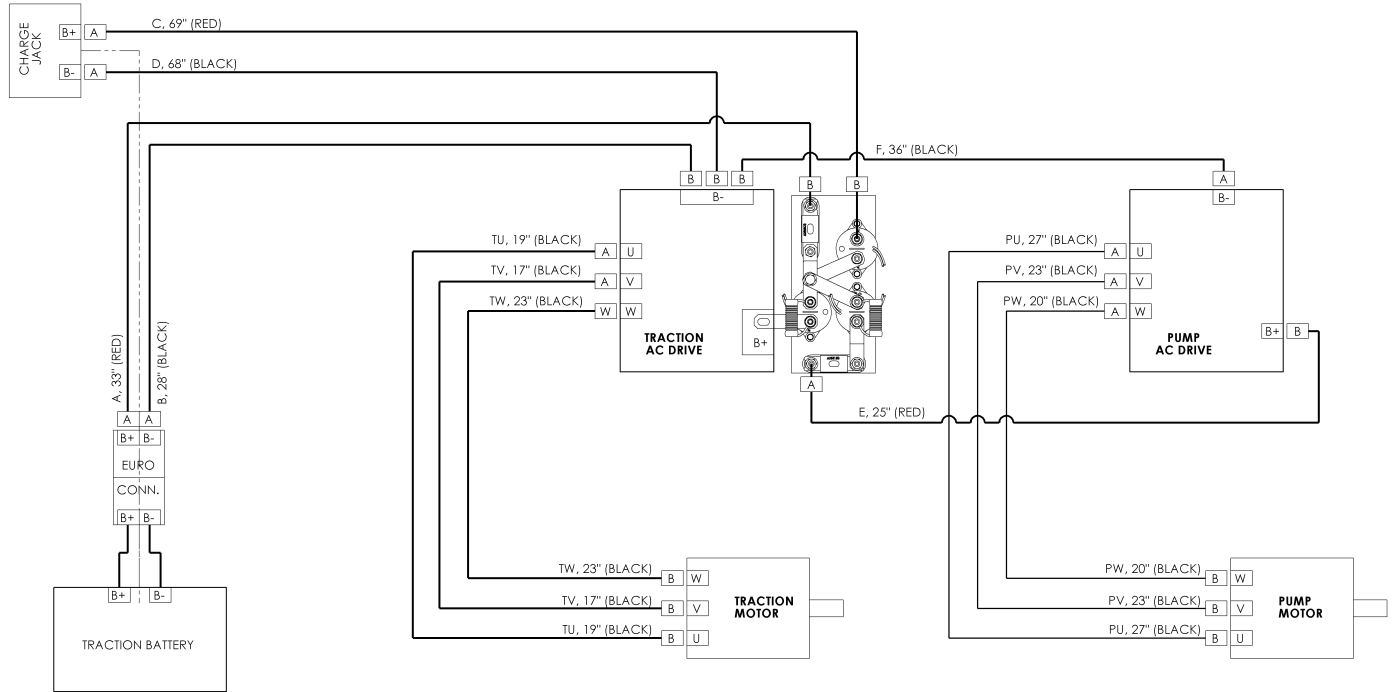

ITEM	WIRE				END A		END B	
	GAGE	COLOR	P/N	LENGTH	P/N	TYPE	P/N	TYPE
A	2/0	RED	A-ES12-0498	33"	A-ES12-0447	EURO	A-ES12-0497	STRAIGHT
B	2/0	BLACK	A-ES12-0499	28"	A-ES12-0497	STRAIGHT	A-ES12-0497	STRAIGHT
C	2/0	RED	A-ES12-0498	69"	A-ES12-0497	STRAIGHT	A-ES12-0497	STRAIGHT
D	2/0	BLACK	A-ES12-0499	68"	A-ES12-0497	STRAIGHT	A-ES12-0497	STRAIGHT
E	1/0	RED	NVSP-33-010-CA	25"	NVSP-33-011-CA	90°	A-ES12-0503	STRAIGHT
F	1/0	BLACK	A-ES12-0502	36"	A-ES12-0503	STRAIGHT	A-ES12-0503	STRAIGHT
PU	1/0	BLACK	A-ES12-0502	27"	A-ES12-0503	STRAIGHT	A-ES12-0503	STRAIGHT
PV	1/0	BLACK	A-ES12-0502	23"	A-ES12-0503	STRAIGHT	A-ES12-0503	STRAIGHT
PW	1/0	BLACK	A-ES12-0502	20"	A-ES12-0503	STRAIGHT	A-ES12-0503	STRAIGHT
TU	2/0	BLACK	A-ES12-0499	19"	A-ES12-0497	STRAIGHT	A-ES12-0497	STRAIGHT
TV	2/0	BLACK	A-ES12-0499	17"	A-ES12-0497	STRAIGHT	A-ES12-0497	STRAIGHT
TW	2/0	BLACK	A-ES12-0499	23"	A-ES12-0497	STRAIGHT	A-ES12-0497	STRAIGHT

Battery Cable Schematic

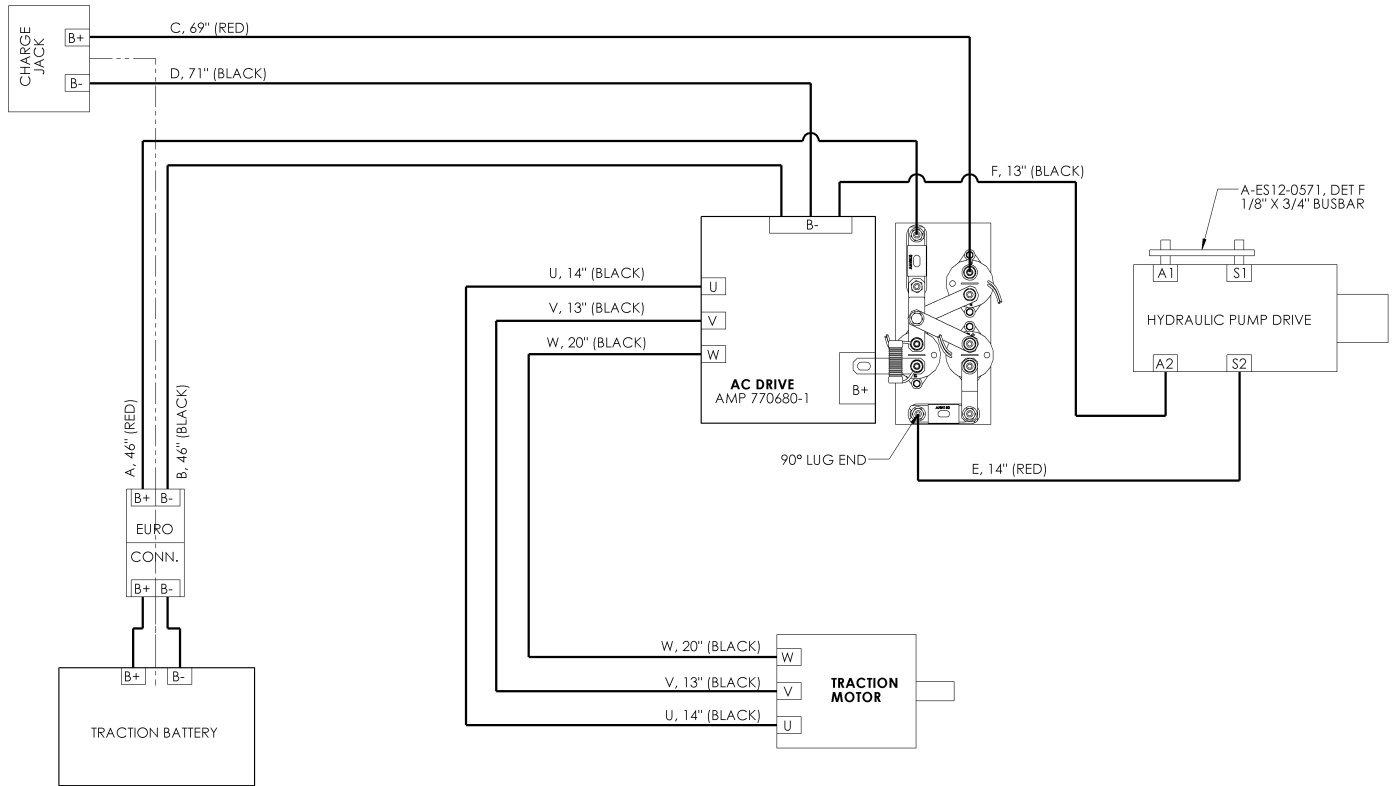

ITEM	WIRE				END A		END B	
	GAGE	COLOR	P/N	LENGTH	P/N	TYPE	P/N	TYPE
A	2/0	RED	A-ES12-0498	46"	A-ES12-0447	EURO	A-ES12-0497	STRAIGHT
B	2/0	BLACK	A-ES12-0499	46"			A-ES12-0497	STRAIGHT
C	2/0	RED	A-ES12-0498	69"	A-ES12-0497	STRAIGHT	A-ES12-0497	STRAIGHT
D	2/0	BLACK	A-ES12-0499	71"	A-ES12-0497	STRAIGHT	A-ES12-0497	STRAIGHT
E	2/0	RED	A-ES12-0498	14"	A-ES12-0497	STRAIGHT	A-ES12-0501	90°
F	2/0	BLACK	A-ES12-0499	13"	A-ES12-0497	STRAIGHT	A-ES12-0497	STRAIGHT
U	2/0	BLACK	A-ES12-0499	14"	A-ES12-0497	STRAIGHT	A-ES12-0497	STRAIGHT
V	2/0	BLACK	A-ES12-0499	13"	A-ES12-0497	STRAIGHT	A-ES12-0497	STRAIGHT
W	2/0	BLACK	A-ES12-0499	20"	A-ES12-0497	STRAIGHT	A-ES12-0497	STRAIGHT

Battery Cable Schematic

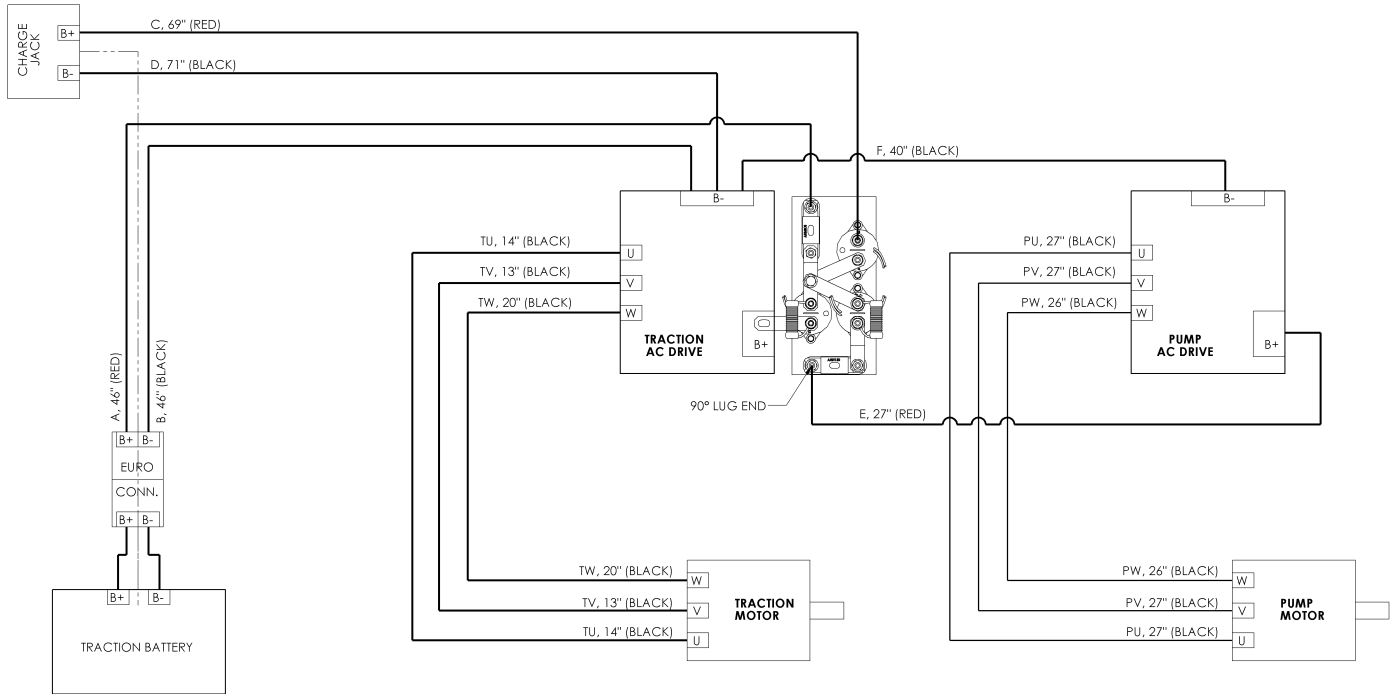

ITEM	WIRE				END A		END B	
	GAGE	COLOR	P/N	LENGTH	P/N	TYPE	P/N	TYPE
A	2/0	RED	A-ES12-0498	46"	A-ES12-0447	EURO	A-ES12-0497	STRAIGHT
B	2/0	BLACK	A-ES12-0499	46"	A-ES12-0497	STRAIGHT	A-ES12-0497	STRAIGHT
C	2/0	RED	A-ES12-0498	69"	A-ES12-0497	STRAIGHT	A-ES12-0497	STRAIGHT
D	2/0	BLACK	A-ES12-0499	71"	A-ES12-0497	STRAIGHT	A-ES12-0497	STRAIGHT
E	2/0	RED	A-ES12-0498	27"	A-ES12-0497	STRAIGHT	A-ES12-0501	90°
F	2/0	BLACK	A-ES12-0499	40"	A-ES12-0497	STRAIGHT	A-ES12-0497	STRAIGHT
PU	1/0	BLACK	A-ES12-0502	27"	A-ES12-0503	STRAIGHT	A-ES12-0503	STRAIGHT
PV	1/0	BLACK	A-ES12-0502	27"	A-ES12-0503	STRAIGHT	A-ES12-0503	STRAIGHT
PW	1/0	BLACK	A-ES12-0502	26"	A-ES12-0503	STRAIGHT	A-ES12-0503	STRAIGHT
TU	2/0	BLACK	A-ES12-0499	14"	A-ES12-0497	STRAIGHT	A-ES12-0497	STRAIGHT
TV	2/0	BLACK	A-ES12-0499	13"	A-ES12-0497	STRAIGHT	A-ES12-0497	STRAIGHT
TW	2/0	BLACK	A-ES12-0499	20"	A-ES12-0497	STRAIGHT	A-ES12-0497	STRAIGHT

Battery Cable Schematic

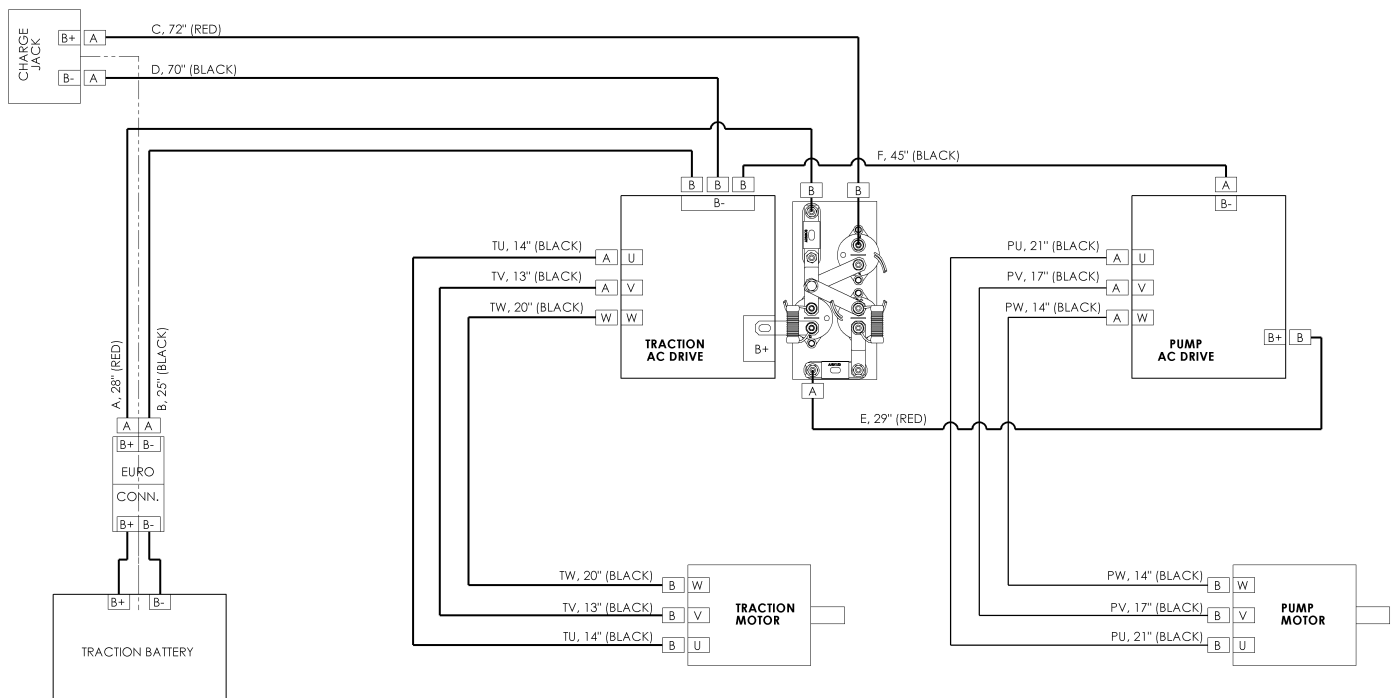

ITEM	WIRE				END A		END B	
	GAGE	COLOR	P/N	LENGTH	P/N	TYPE	P/N	TYPE
A	2/0	RED	A-ES12-0498	27"	A-ES12-0447	EURO	A-ES12-0497	STRAIGHT
B	2/0	BLACK	A-ES12-0499	28"	A-ES12-0497	EURO	A-ES12-0497	STRAIGHT
C	2/0	RED	A-ES12-0498	72"	A-ES12-0497	STRAIGHT	A-ES12-0497	STRAIGHT
D	2/0	BLACK	A-ES12-0499	70"	A-ES12-0497	STRAIGHT	A-ES12-0497	STRAIGHT
E	1/0	RED	NVSP-33-010-CA	29"	A-ES12-0503	STRAIGHT	A-ES12-0503	STRAIGHT
F	1/0	BLACK	A-ES12-0502	45"	A-ES12-0503	STRAIGHT	A-ES12-0503	STRAIGHT
PU	1/0	BLACK	A-ES12-0502	21"	A-ES12-0503	STRAIGHT	A-ES12-0503	STRAIGHT
PV	1/0	BLACK	A-ES12-0502	17"	A-ES12-0503	STRAIGHT	A-ES12-0503	STRAIGHT
PW	1/0	BLACK	A-ES12-0502	14"	A-ES12-0503	STRAIGHT	A-ES12-0503	STRAIGHT
TU	2/0	BLACK	A-ES12-0499	14"	A-ES12-0497	STRAIGHT	A-ES12-0497	STRAIGHT
TV	2/0	BLACK	A-ES12-0499	13"	A-ES12-0497	STRAIGHT	A-ES12-0497	STRAIGHT
TW	2/0	BLACK	A-ES12-0499	20"	A-ES12-0497	STRAIGHT	A-ES12-0497	STRAIGHT

Battery Cables - Hydraulic Pump Drive

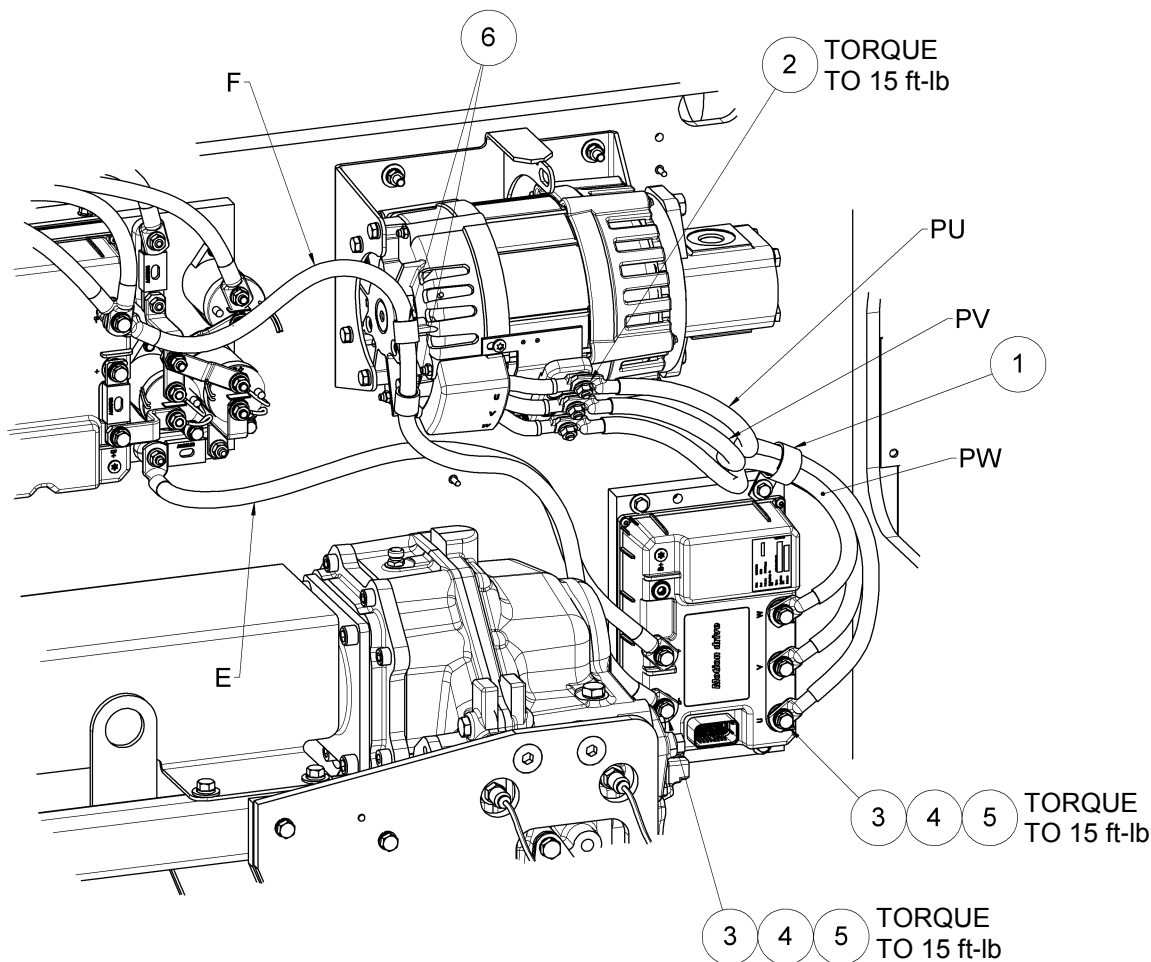

Item	Part Number	Qty.	Description
1	NPN	1	CUSHIONED LOOP CLAMP, 1.25
2	NPN	3	FLANGE NUT, M8 (INCLUDED WITH MOTOR)
3	NPN	5	HCS, M8X1.25 X 25
4	NPN	5	LOCK WASHER, M8
5	NPN	5	FLAT WASHER, M8
6	NPN	2	CUSHIONED LOOP CLAMP, .75

Battery Cables - Hydraulic Pump Drive

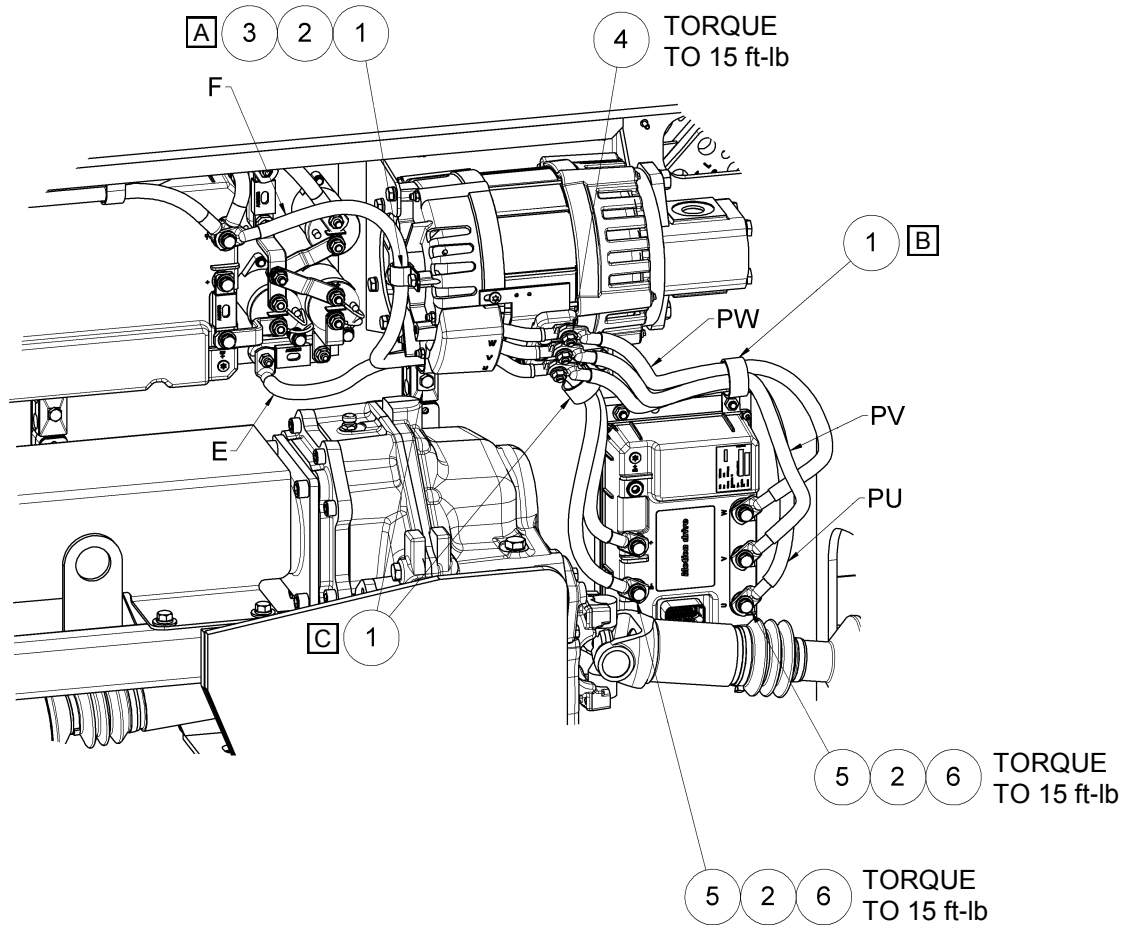

- A** Cushioned loop clamp mounted to rear of AC pump motor.
- B** Cushioned loop clamp mounted using AC pump controller mounting hardware.
- C** Cushioned loop clamp mounted to top of hydraulic hose clamps using hose clamp hardware.

Item	Part Number	Qty.	Description
1	NPN	4	CUSHIONED LOOP CLAMP
2	NPN	6	LOCK WASHER, M8
3	NPN	1	HCS, M8X1.25 X 16
4	NPN	3	FLANGE NUT, M8 (INCLUDED WITH MOTOR)
5	NPN	5	HCS, M8X1.25 X 25
6	NPN	5	FLAT WASHER, M8

Battery Cables - Hydraulic Pump Drive

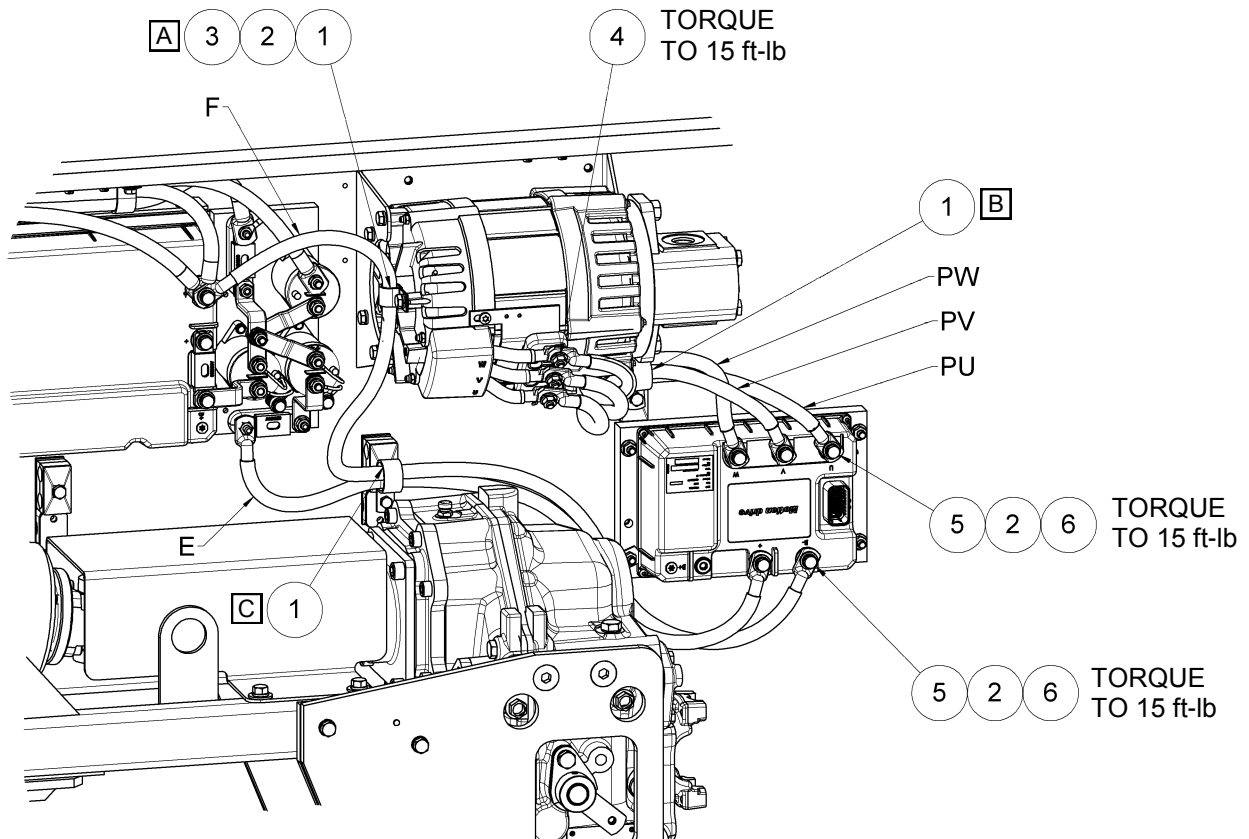

- A** Cushioned loop clamp mounted to rear of AC pump motor.
- B** Cushioned loop clamp mounted using AC pump controller mounting hardware.
- C** Cushioned loop clamp mounted to top of hydraulic hose clamps using hose clamp hardware.

Item	Part Number	Qty.	Description
1	NPN	3	CUSHIONED LOOP CLAMP
2	NPN	6	LOCK WASHER, M8
3	NPN	1	HCS, M8X1.25 X 16
4	NPN	3	FLANGE NUT, M8 (INCLUDED WITH MOTOR)
5	NPN	5	HCS, M8X1.25 X 25
6	NPN	5	FLAT WASHER, M8

Battery Cables - Traction Drive

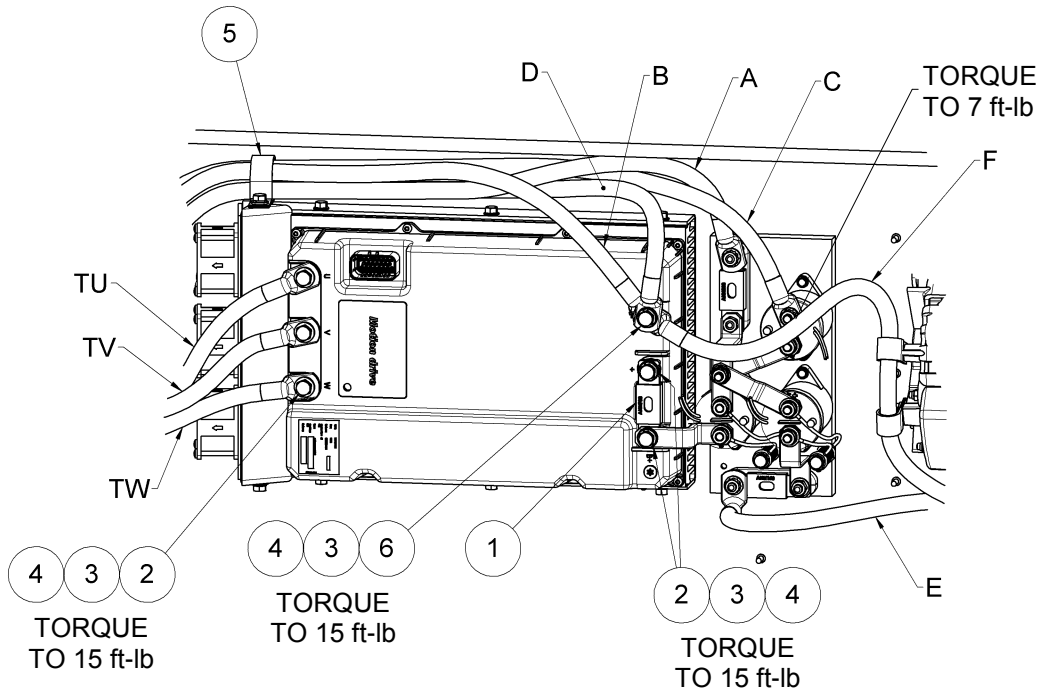

Item	Part Number	Qty.	Description
1	A-ES12-0417	1	TRACTION DRIVE FUSE, 700A
2	NPN	5	HCS, M8X1.25 X 25
3	NPN	6	LOCK WASHER, M8
4	NPN	6	FLAT WASHER, M8
5	NPN	1	CUSHIONED LOOP CLAMP, 1.5
6	NPN	1	HCS, M8X1.25 X 35

Battery Cables - Traction Drive

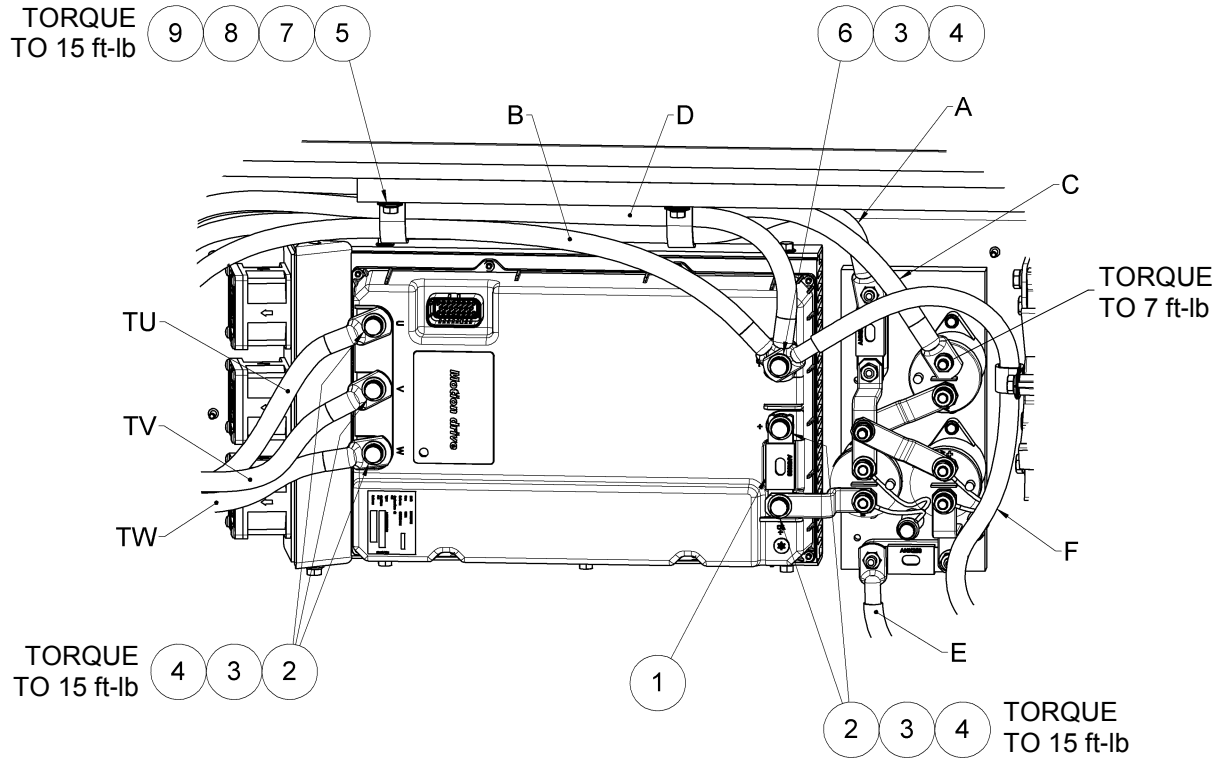

Item	Part Number	Qty.	Description
1	A-ES12-0417	1	TRACTION DRIVE FUSE, 700A
2	NPN	5	HCS, M8X1.25 X 25
3	NPN	6	LOCK WASHER, M8
4	NPN	6	FLAT WASHER, M8
5	NPN	2	CUSHIONED LOOP CLAMP
6	NPN	1	HCS, M8X1.25 X 35
7	NPN	2	HCS, 1/4-20 UNC X .75
8	NPN	2	FLAT WASHER, 1/4
9	NPN	2	LOCK WASHER, 1/4

Battery Cables - Battery Connector

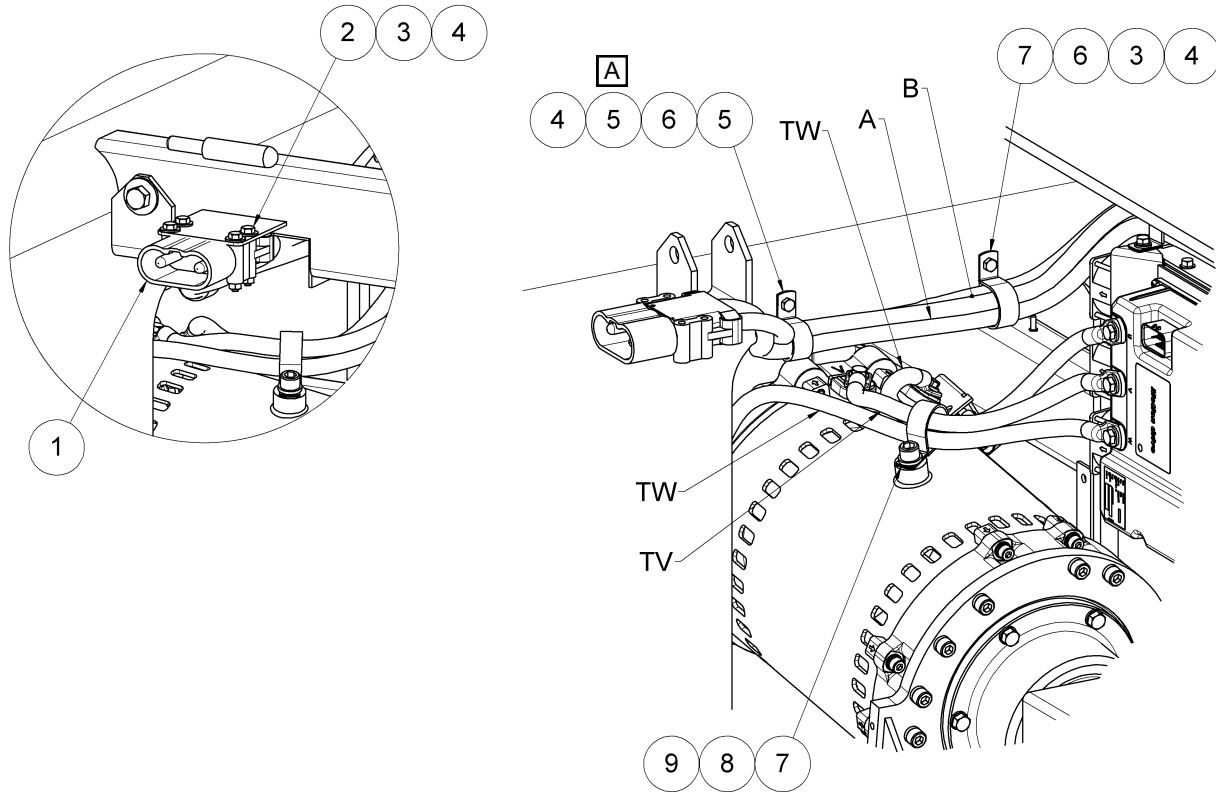

A Second loop clamp is behind the panel. See following pages for details.

Item	Part Number	Qty.	Description
1	A-ES12-0447	1	EURO/DIN BATTERY CONNECTOR KIT
2	NPN	4	HCS, 1/4-20 UNC X 2
3	NPN	5	FLAT WASHER, 1/4
4	NPN	6	LOCK NUT, 1/4-20 UNC
5	NPN	2	CUSHIONED LOOP CLAMP, 1.25
6	NPN	2	HCS, 1/4-20 UNC X 1
7	NPN	2	CUSHIONED LOOP CLAMP, 1.5
8	NPN	1	SHCS, M12X1.75 X 20
9	NPN	1	FLAT WASHER, M12

Battery Cables - Battery Connector

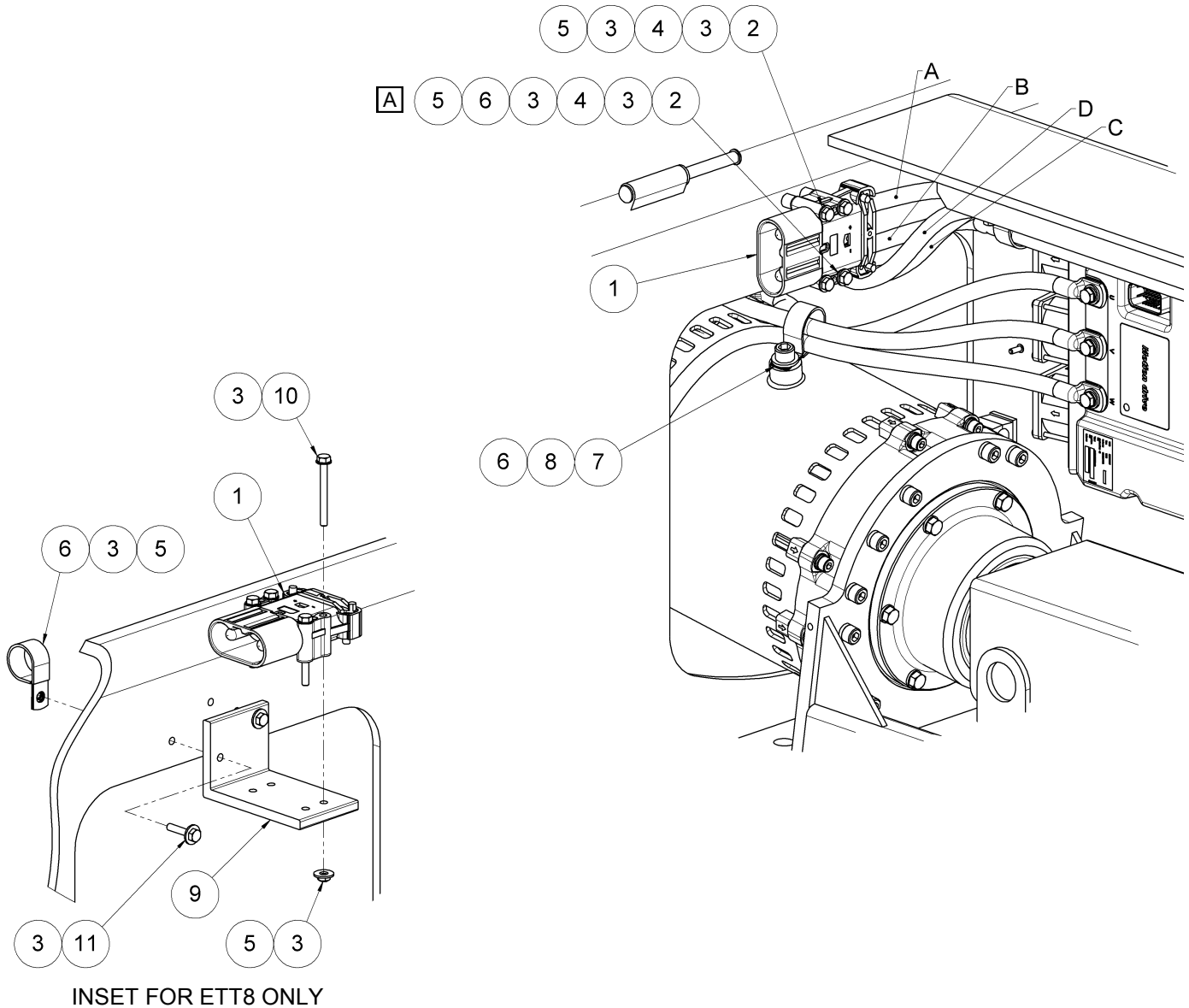

A Loop clamp is behind the panel. See following pages for details.

Item	Part Number	Qty.	Description
1	A-ES12-0447	1	EURO/DIN BATTERY CONNECTOR KIT
2	NPN	AR	HCS, 1/4-20 UNC X 3
3	NPN	AR	FLAT WASHER, .25
4	NPN	AR	SPACER, Ø.5 OD x .5 TALL
5	NPN	AR	LOCK NUT, 1/4-20 UNC
6	NPN	2	CUSHIONED LOOP CLAMP
7	NPN	1	SHCS, M12X1.75 X 20
8	NPN	1	FLAT WASHER, M12
9	Et08-02-005-SA	1	EURO CONNECTOR BRACKET
10	NPN	AR	HCS, 1/4-20 UNC X 1.25
11	NPN	AR	HCS, 1/4-20 UNC X 2.50

Battery Cables - Charge Jack and Traction Motor

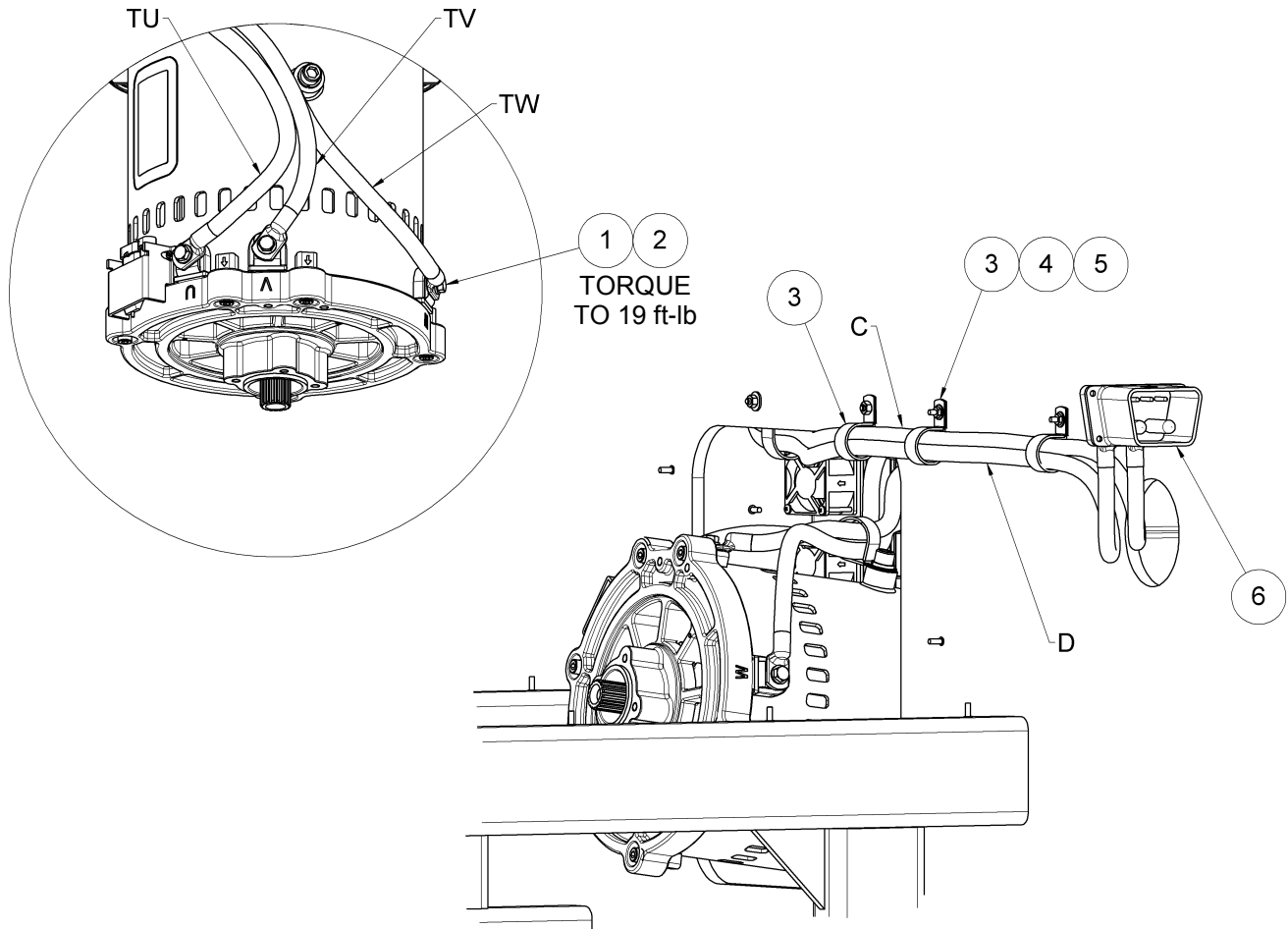

Item	Part Number	Qty.	Description
1	NPN	3	HCS, M8X1.25 X 20
2	NPN	3	FLAT WASHER, M8
3	NPN	3	CUSHIONED LOOP CLAMP, 1.25
4	NPN	2	LOCK NUT, #10-32 UNF
5	NPN	2	FLAT WASHER, #10
6	A-ES12-0422	1	CHARGER CONNECTOR

Battery Cables - Charge Jack and Traction Motor

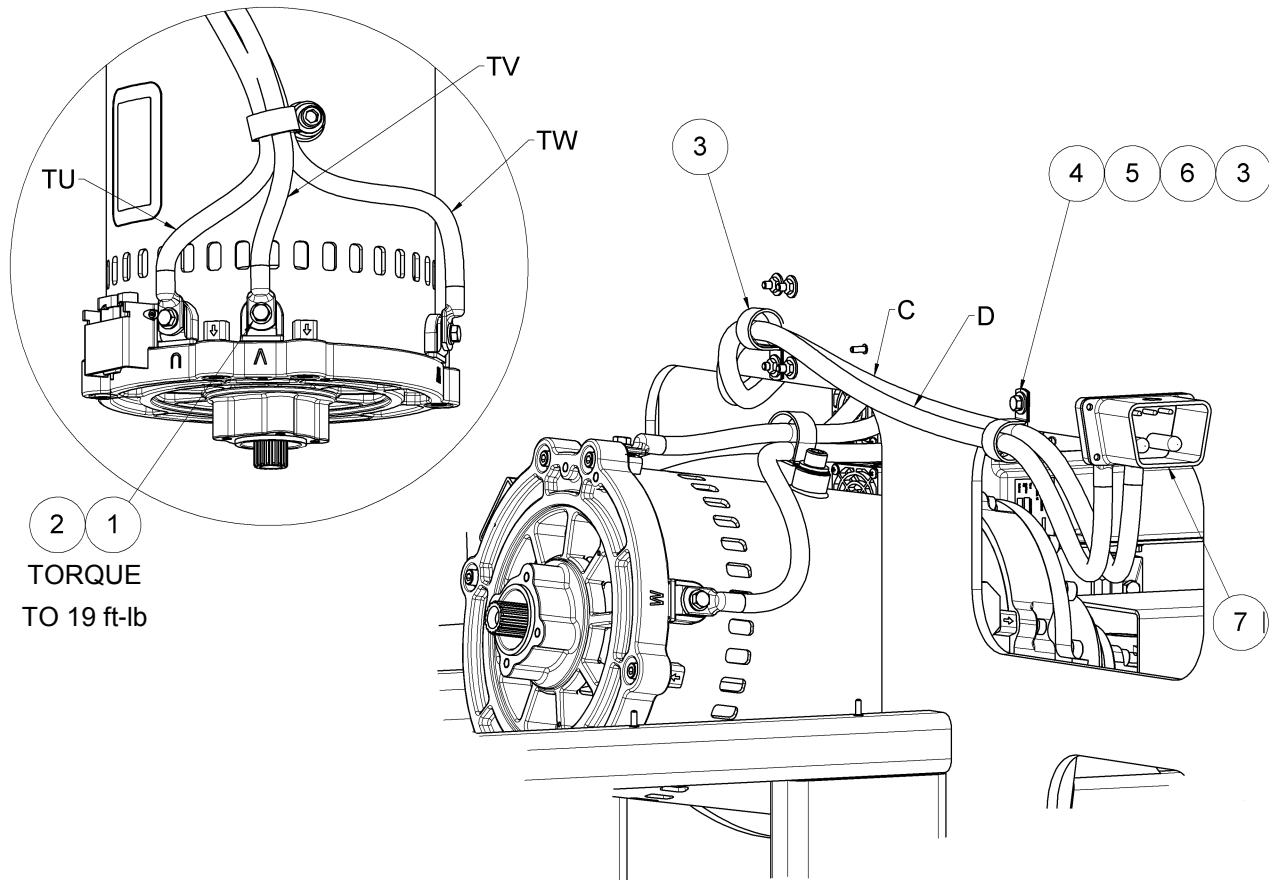

2 1
TORQUE
TO 19 ft-lb

Item	Part Number	Qty.	Description
1	NPN	3	HCS, M8X1.25 X 20
2	NPN	3	FLAT WASHER, M8
3	NPN	3	CUSHIONED LOOP CLAMP, 1.25
4	NPN	1	HCS, 1/4-20 UNC X .50
5	NPN	1	LOCK WASHER, .25
6	NPN	1	FLAT WASHER, .25
7	A-ES12-0422	1	CHARGER CONNECTOR

Vehicle Harness - Front

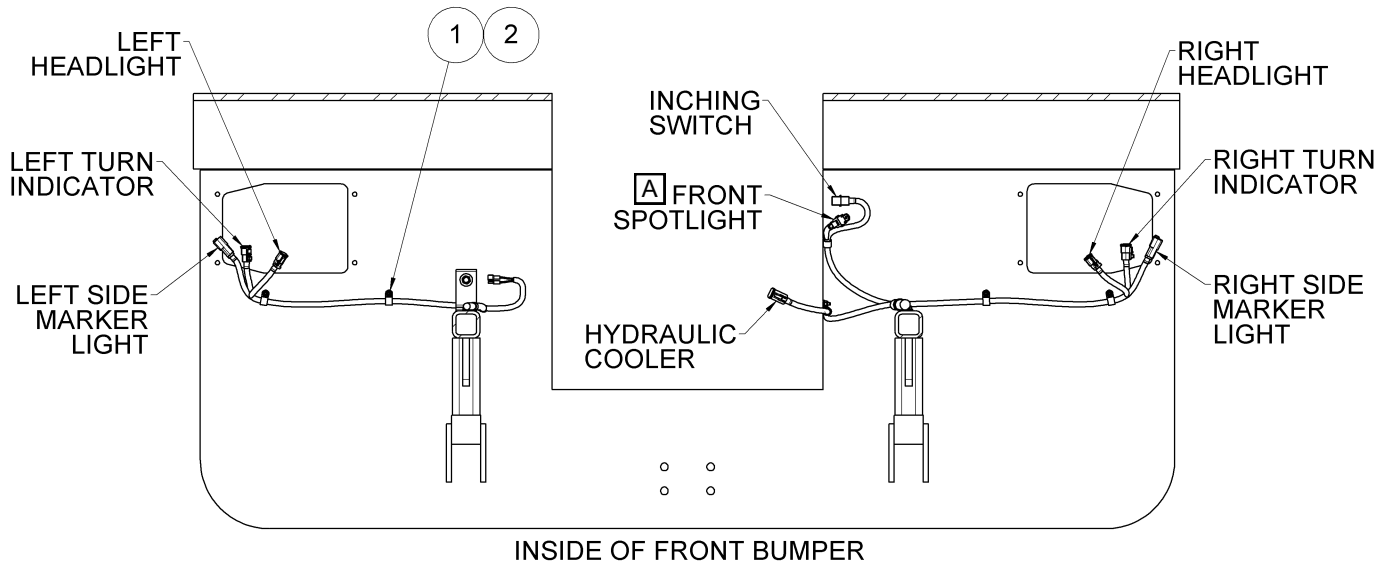

A Connector is tied to harness if optional equipment is not present.

Item	Part Number	Qty.	Description
1	NPN	AS REQ.	PLASTIC LOOP CLAMP
2	NPN	AS REQ.	LOCK NUT, #10-32 UNF

Vehicle Harness - Front

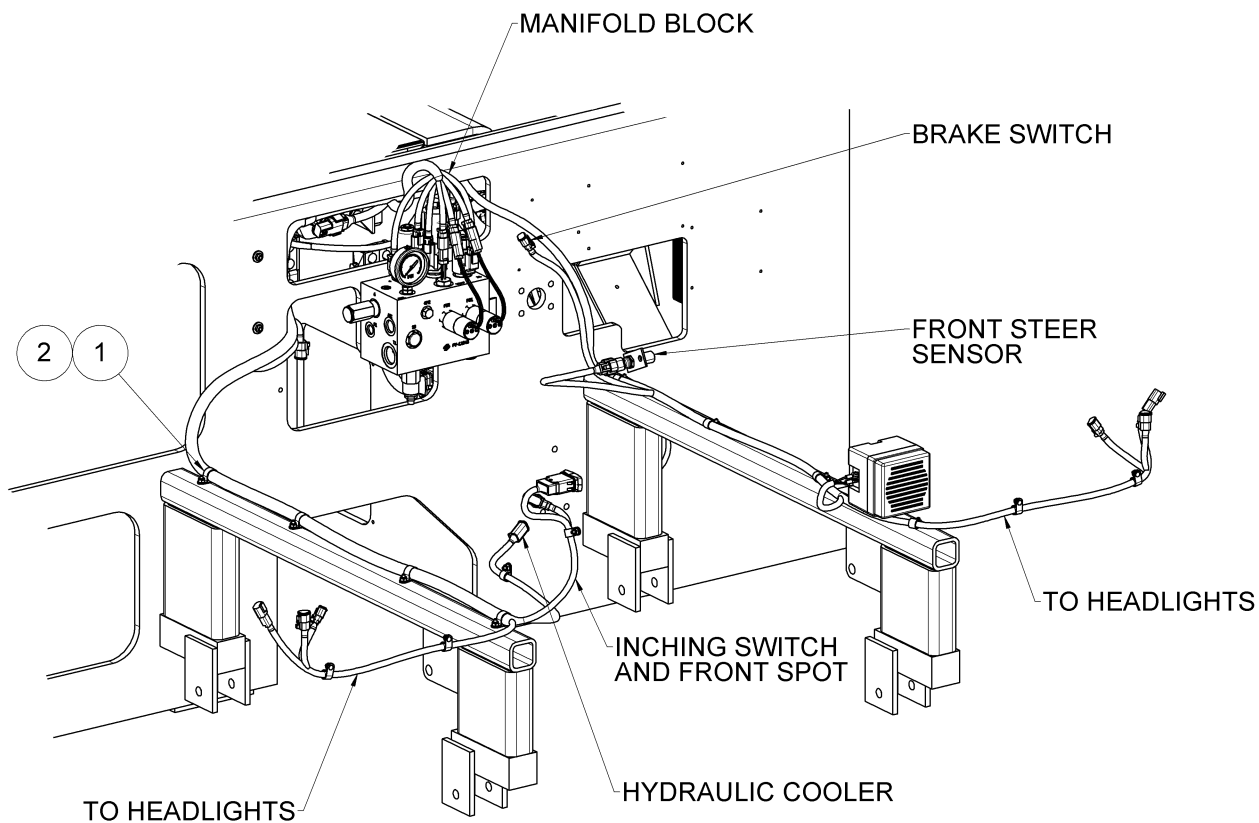

Item	Part Number	Qty.	Description
1	NPN	AS REQ.	PLASTIC LOOP CLAMP
2	NPN	AS REQ.	LOCK NUT, #10-32 UNF

Vehicle Harness - Manifold Block Connections

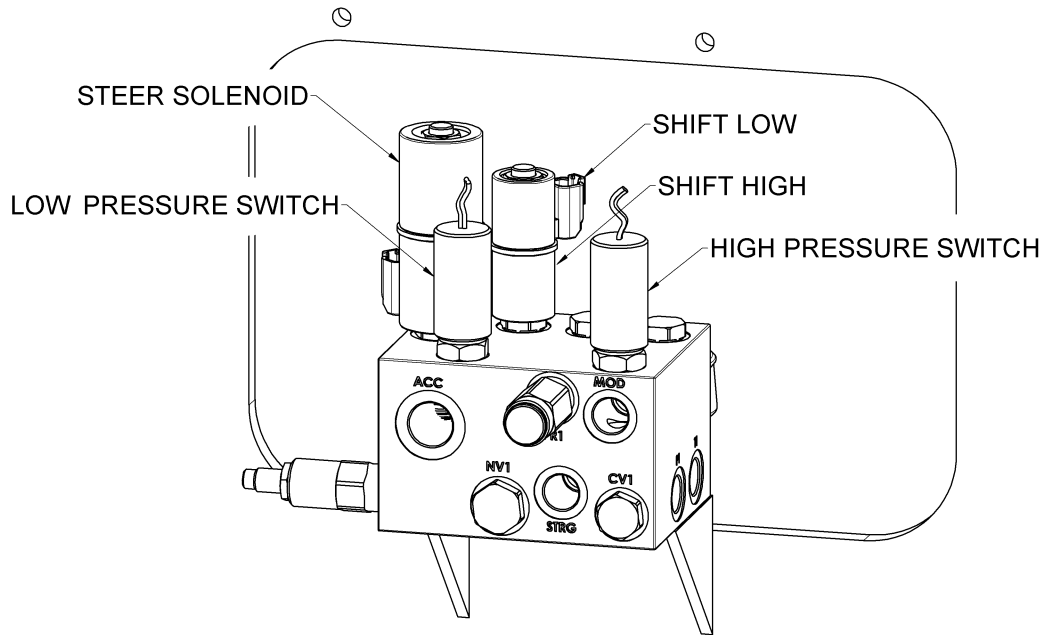

Description/Function	Wire Colors in Vehicle Harness	
	8E112 and earlier 12E117 and earlier, and 12E124	8E113 - 8E119 12E118 - 12E140, excluding 12E124
STEER SOLENOID (TOP)	PINK / BROWN	BLUE / BROWN
STEER SOLENOID (BOTTOM)	PINK / WHITE	GREEN / WHITE
SHIFT LOW	PINK / TAN	GREY / TAN
SHIFT HIGH	PINK / BLUE	ORANGE / BLUE
HIGH PRESSURE SWITCH	RED / YELLOW	BLUE / YELLOW
LOW PRESSURE SWITCH	RED / PURPLE	GREEN/ PURPLE

Vehicle Harness - Manifold Block Connections

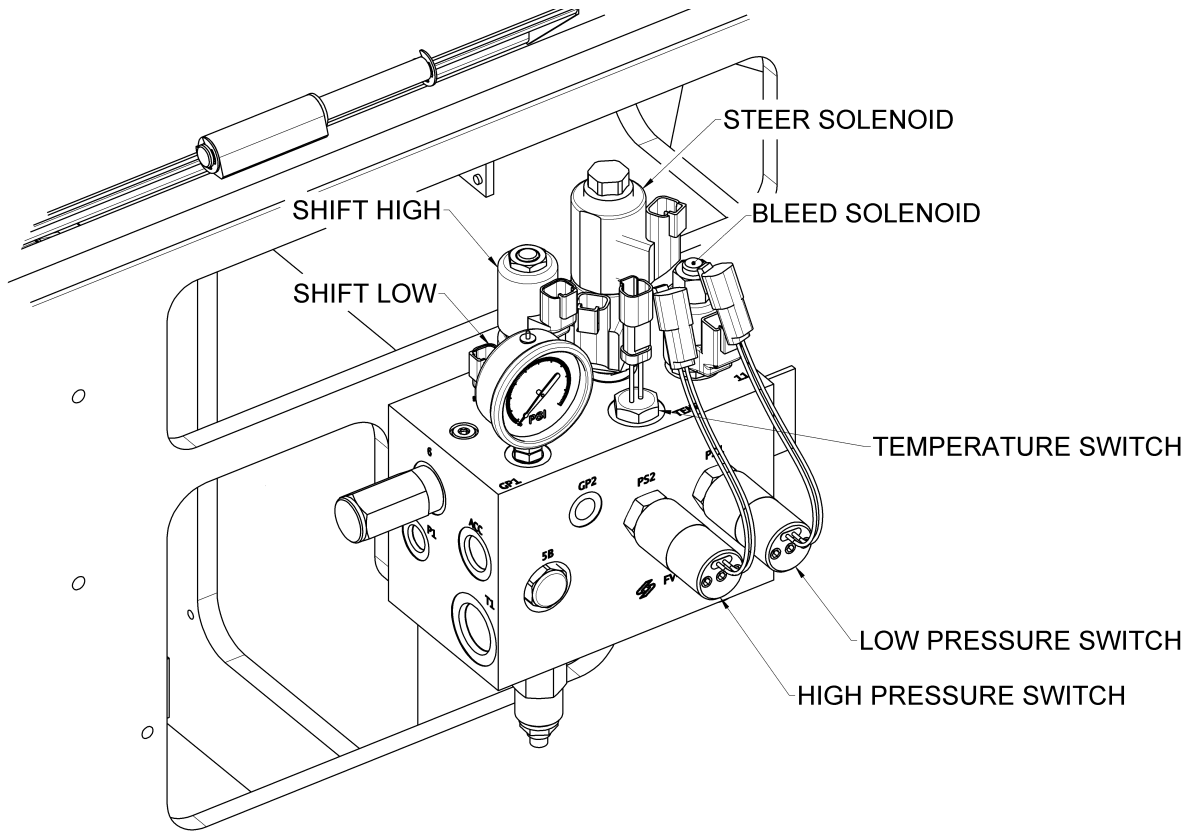

Description/Function	Wire Colors in Vehicle Harness
STEER SOLENOID (TOP)	BLUE / BROWN
STEER SOLENOID (BOTTOM)	GREEN / WHITE
SHIFT LOW	GREY / TAN
SHIFT HIGH	ORANGE / BLUE
HIGH PRESSURE SWITCH	BLUE / YELLOW
LOW PRESSURE SWITCH	BLUE / PURPLE
BLEED SOLENOID	TAN / GREEN
TEMPERATURE SWITCH	PINK / TAN

Vehicle Harness - Power Distribution

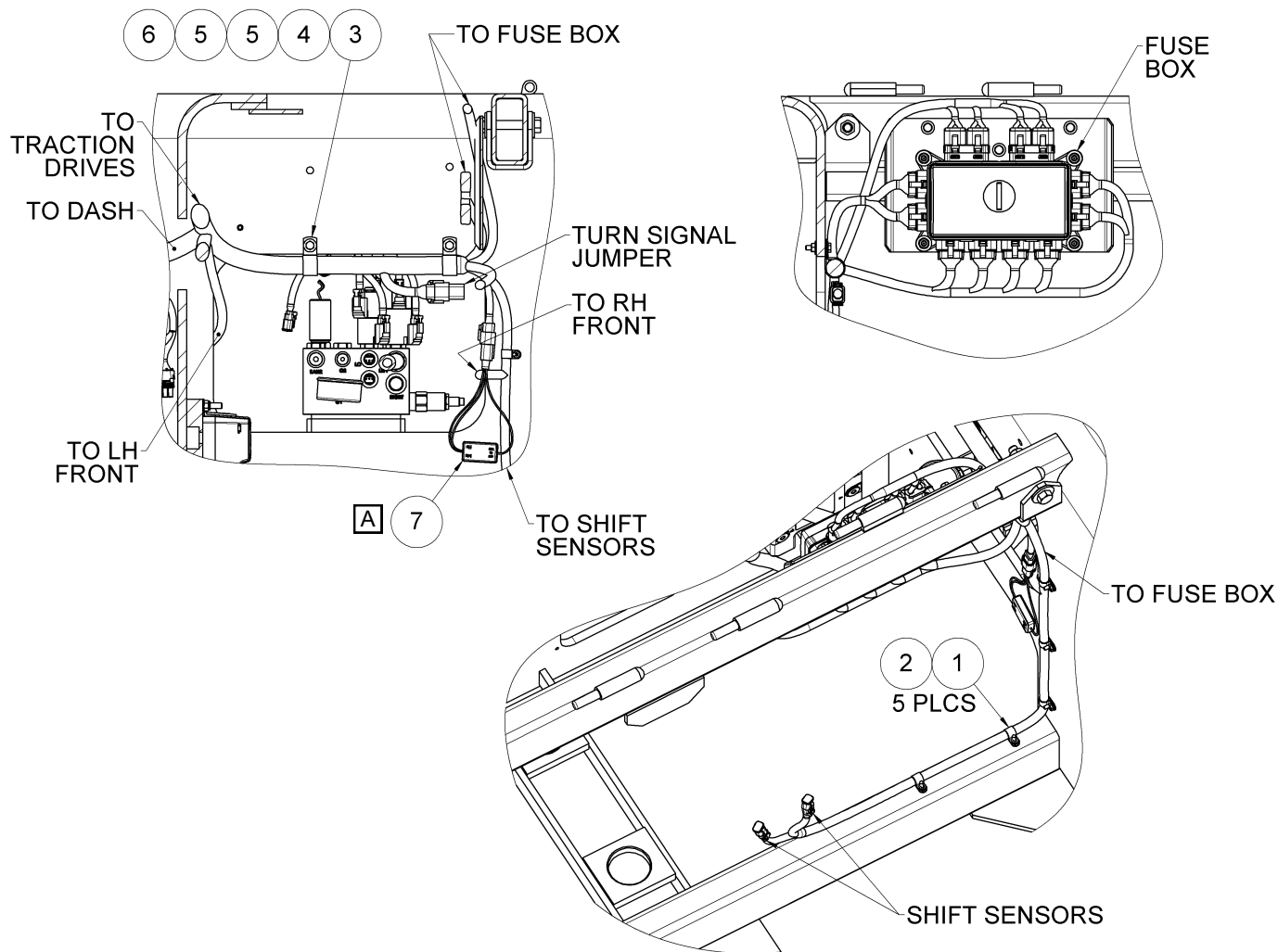

A Adhere to sheet metal using included double-sided adhesive.

Item	Part Number	Qty.	Description
1	NPN	5	PLASTIC LOOP CLAMP
2	NPN	5	LOCK NUT, #10-32 UNF
3	NPN	2	CUSHIONED LOOP CLAMP
4	NPN	2	HCS, 1/4-20 UNC X 1.25
5	NPN	4	FLAT WASHER, 1/4
6	NPN	2	LOCK NUT, 1/4-20 UNC
7	XL00-05-020-CB	1	SIDE INDICATOR FLASHER
N/A	DT04-3P	1	ELECTRICAL CONNECTOR (INSTALLED TO ITEM 7)
N/A	W3P	1	CONNECTOR LOCK (INSTALLED TO ITEM 7)
N/A	0460-215-16141	3	CONNECTOR PINS (INSTALLED TO ITEM 7)

Item 7 to be wired as shown below.

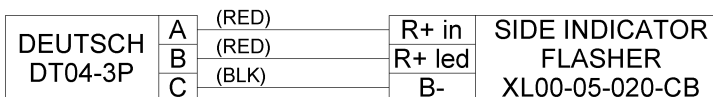

Vehicle Harness - Power Distribution

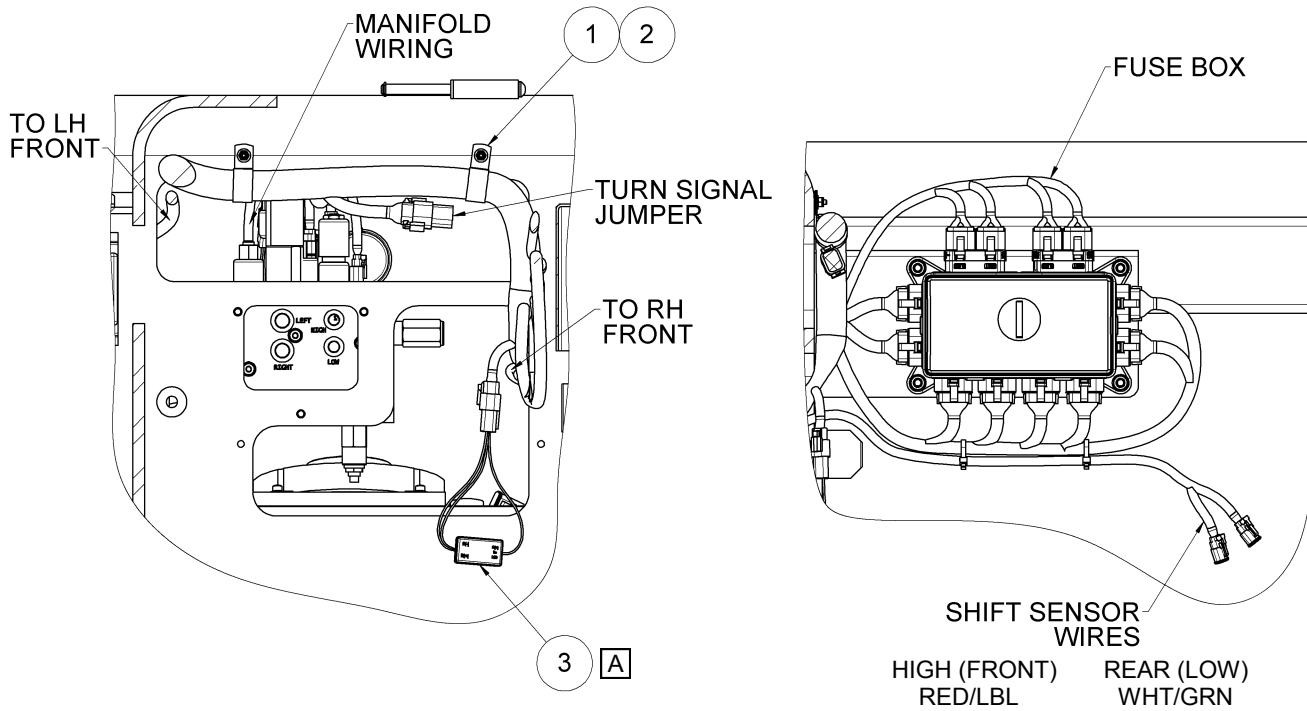

A Adhere to sheet metal using included double-sided adhesive.

Item	Part Number	Qty.	Description
1	NPN	2	PLASTIC LOOP CLAMP
2	NPN	2	LOCK NUT, #10-32 UNF
3	XL00-05-020-CB	1	SIDE INDICATOR FLASHER
N/A	DT04-3P	1	ELECTRICAL CONNECTOR (INSTALLED TO ITEM 3)
N/A	W3P	1	CONNECTOR LOCK (INSTALLED TO ITEM 3)
N/A	0460-215-16141	3	CONNECTOR PINS (INSTALLED TO ITEM 3)

Item 3 to be wired as shown below.

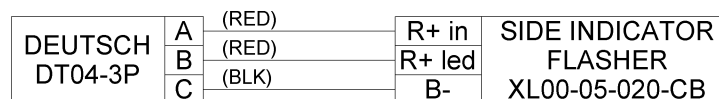

Vehicle Harness - Power Distribution

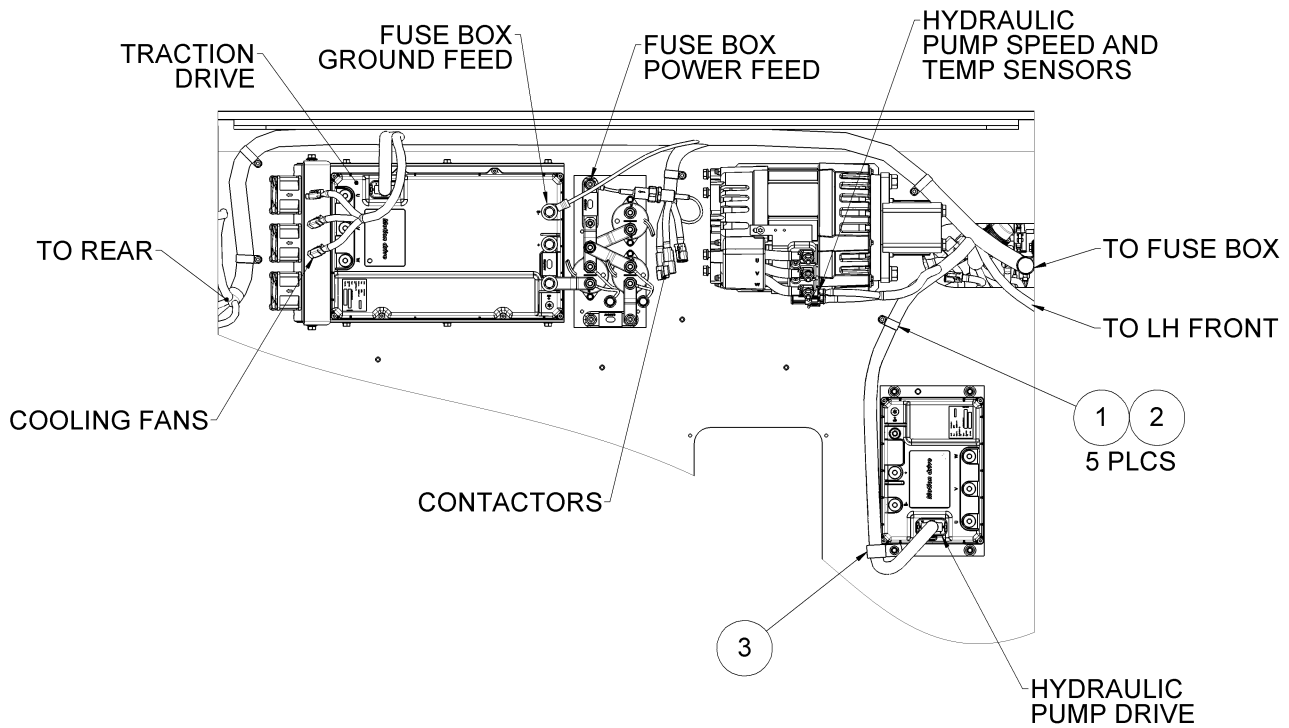

Item	Part Number	Qty.	Description
1	NPN	5	PLASTIC LOOP CLAMP
2	NPN	5	LOCK NUT, #10-32 UNF
3	NPN	1	CUSHIONED LOOP CLAMP

Vehicle Harness - Traction and Pump Drives

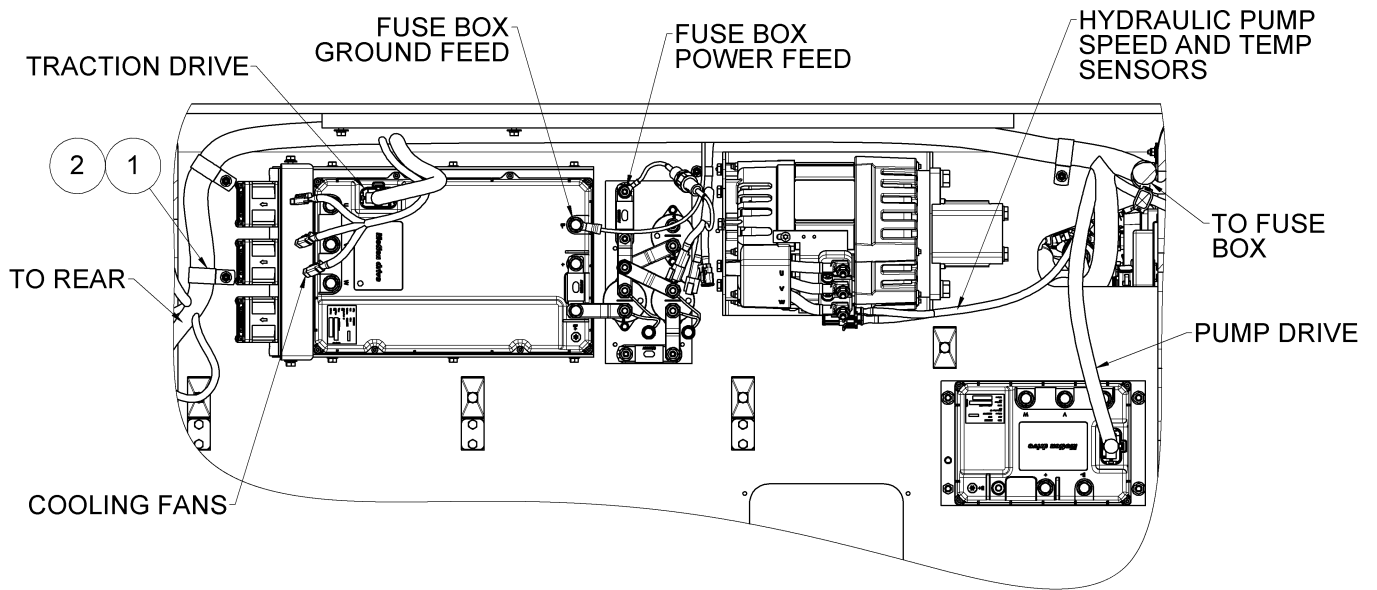

Item	Part Number	Qty.	Description
1	NPN	3	PLASTIC LOOP CLAMP
2	NPN	3	LOCK NUT, #10-32 UNF

Vehicle Harness - Rear

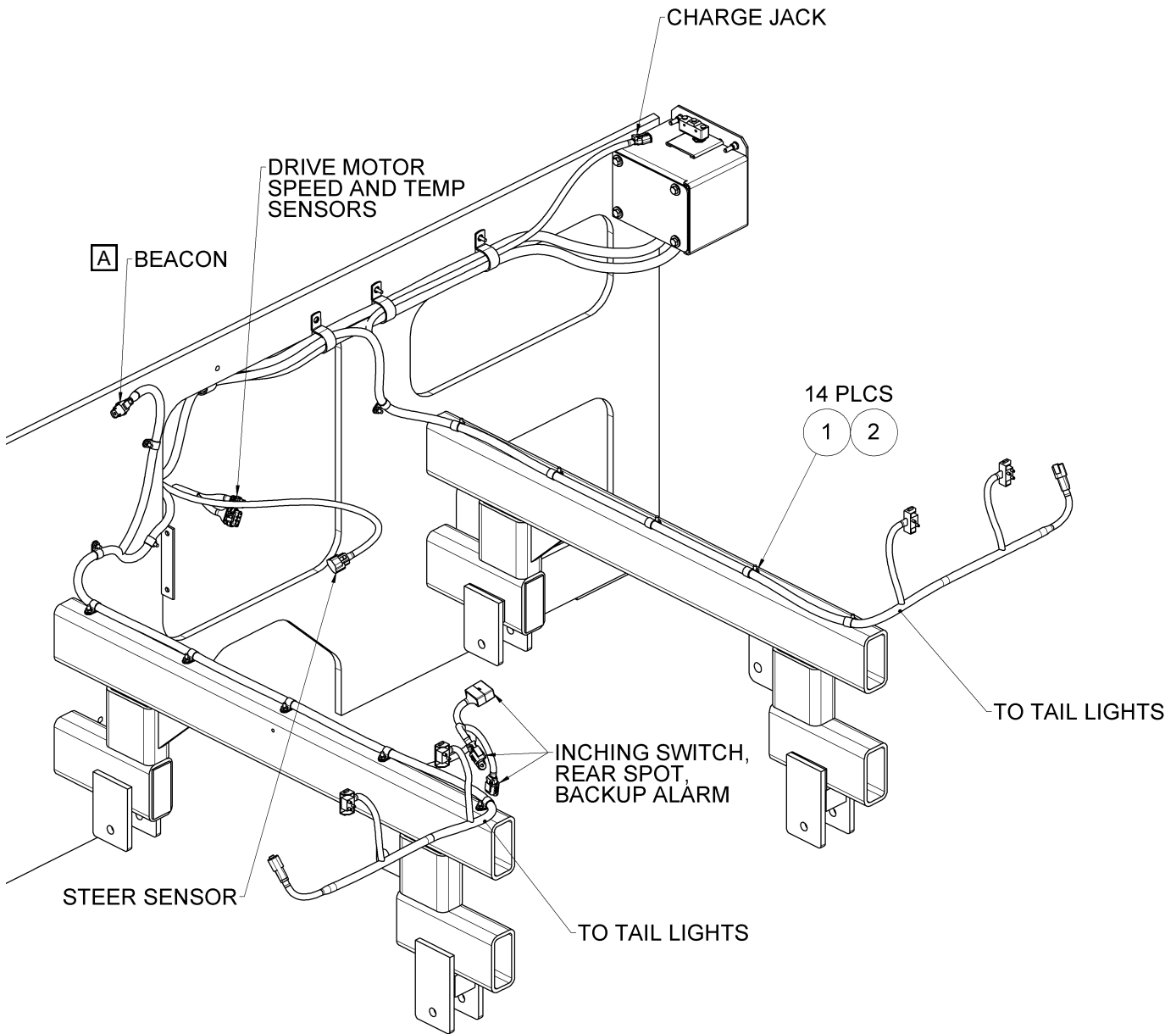

[A] Connector is tied to harness if optional equipment is not present.

Item	Part Number	Qty.	Description
1	NPN	13	PLASTIC LOOP CLAMP
2	NPN	13	LOCK NUT, #10-32 UNF

Vehicle Harness - Rear

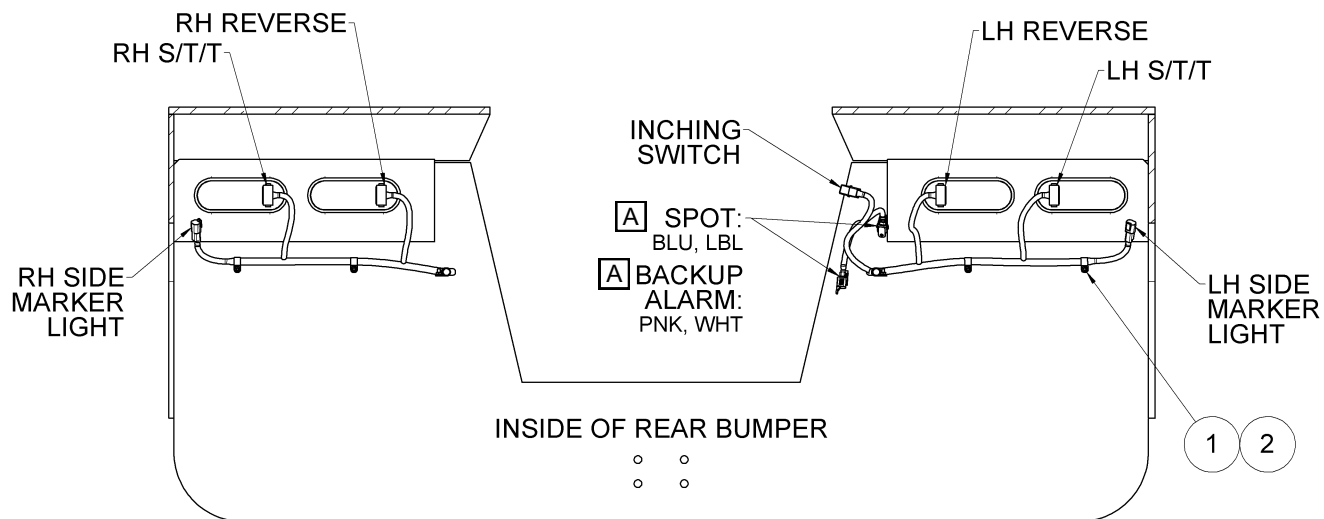

DUAL TAIL-LIGHTS

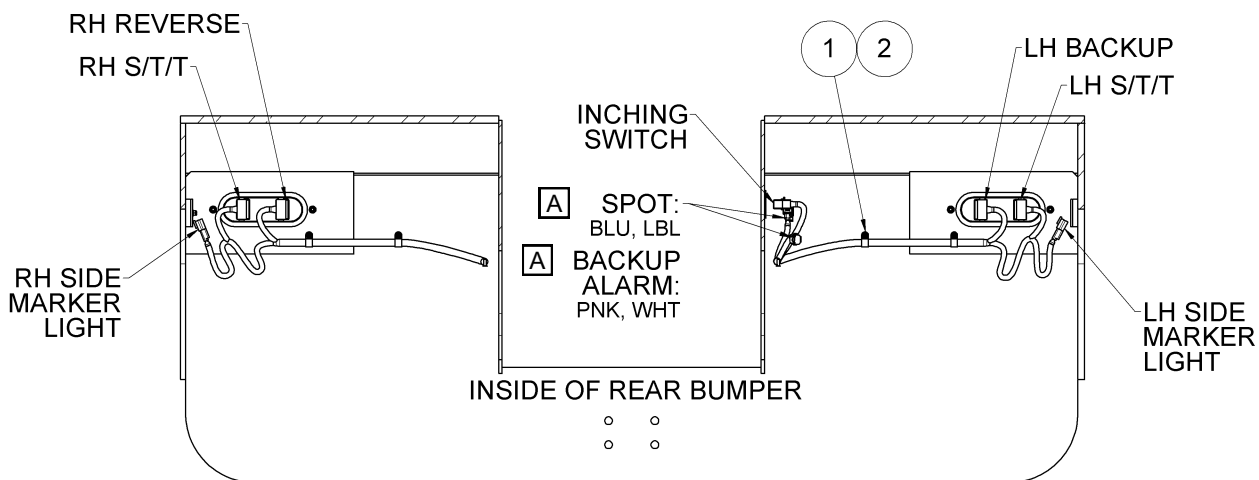

SINGLE TAIL-LIGHTS

A Connector is tied to harness if optional equipment is not present.

Item	Part Number	Qty.	Description
1	NPN	4	PLASTIC LOOP CLAMP
2	NPN	4	LOCK NUT, #10-32 UNF

Vehicle Harness - Under Dash

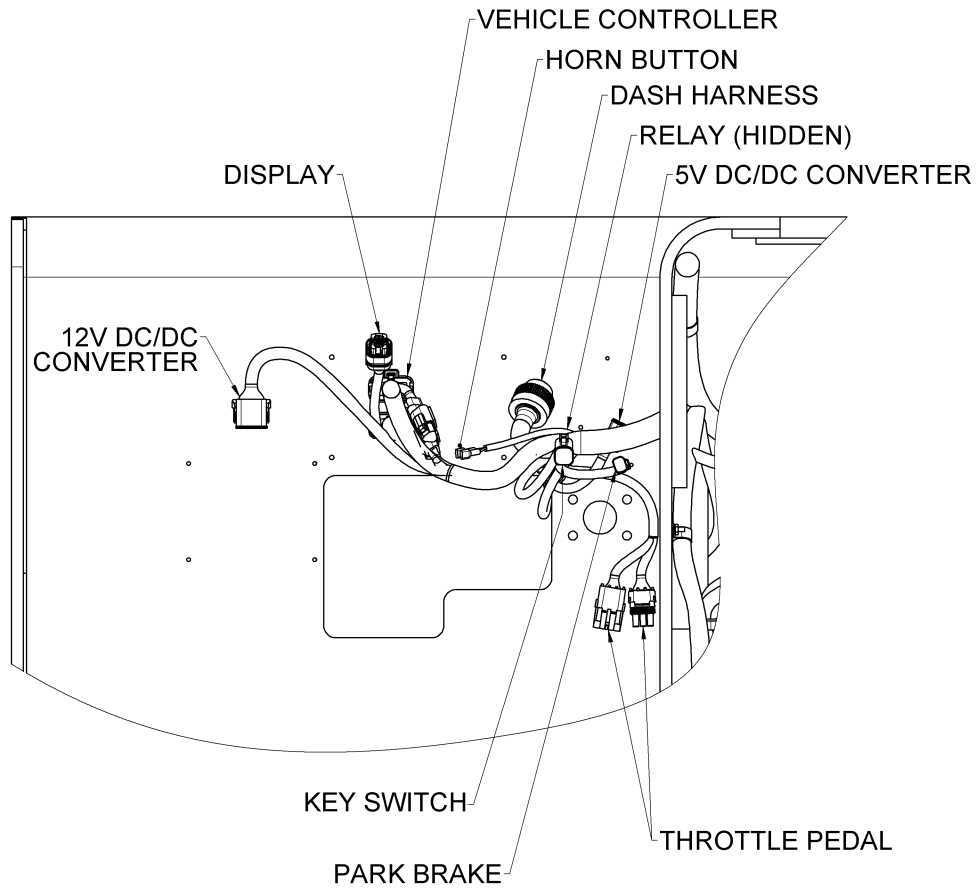

Battery Installation

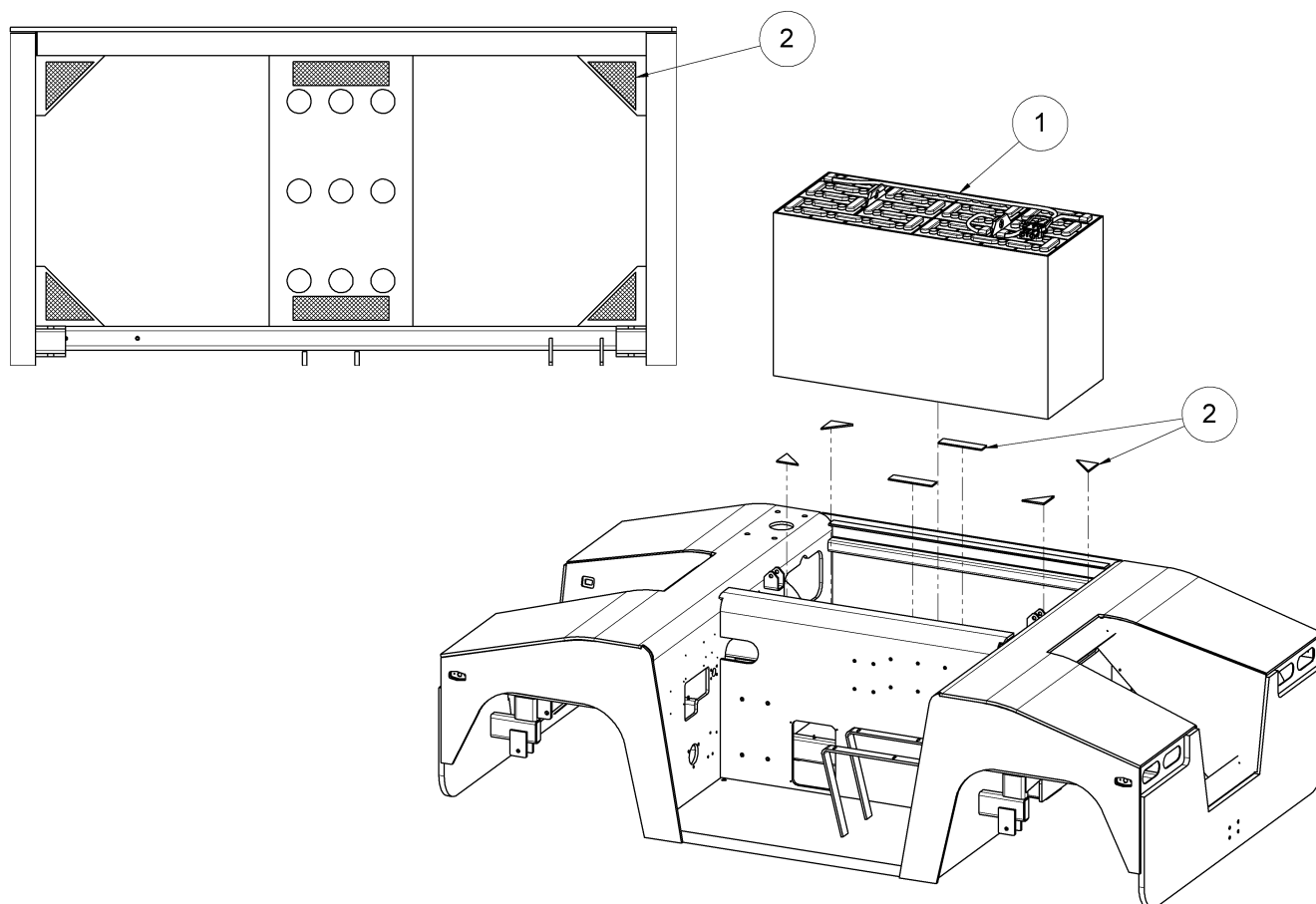

Item	Part Number	Qty.	Description
1	AE-OPT-1200-ETT8	1	TRACTION BATTERY, 80V, 400 AH (eTT8 ONLY)
1	AE-OPT-1200	1	TRACTION BATTERY, 80V, 625 AH (eTT12 ONLY)
2	A-ES12-0448	.5	SELF-ADHESIVE BATTERY PAD (APPLY AS SHOWN)

Revision Log

Rev	Date	Description	Appr.
A	27-Mar-2014	Original release for production.	PRB
B	23-Jun-2014	Updated for new throttle pedal and adaptor harness.	PRB
C	08-Aug-2014	Updated throttle pedal part number.	PRB
D	02-Sep-2014	Added historical throttle pedal information.	SEB
E	2-Feb-2015	Updated for eTT rev G tractors	PRB
F	1-May-2015	Application serial number range updated to reflect production sequencing. Corrected turn signal part number. Corrected eTT8 battery connector mounting.	SEB
G	20-May-2015	Added torque requirement to U-V-W wires at traction motor. Corrected headlight wire polarity for NVSP-34-007-CA.	DCM
H	6-Jan-2016	Revised headlight schematic.	DCM
J	17-Aug-2016	Added new charge jack install	TFP
K	26-Aug-2016	Added new battery cables - hydraulic pump drive for ETT12	TFP
L	11-Nov-2016	Updated a battery cable length	SEB
M	23-May-2017	Added wire color identification for electrical connections to manifold block.	SEB

Section 6 - Hydraulic Sub-Assemblies	
Description	Page
Hydraulic Pump Assembly	6-1
Manifold Pressure Switches	6-5
Hydraulic Manifold Assembly	6-6
Manifold Assembly With Filter and Accumulator	6-13
Brake Pedal Assembly	6-14
Cooler Assembly	6-15
Return Filter Assembly	6-16
Tank Assembly	6-17
Revision Log	6-18

Hydraulic Pump Assembly

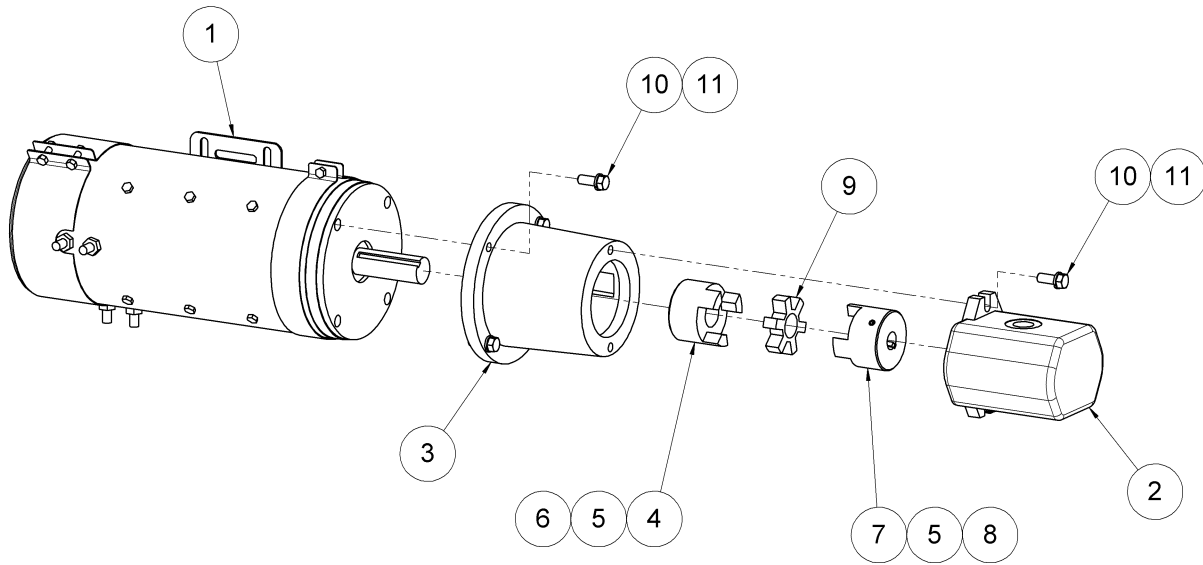

Item	Part Number	Qty.	Description
1	A-ES12-0475	1	DC HYDRAULIC MOTOR
2	A-ES12-0450	1	GEAR PUMP
3	A-ES12-0473	1	PUMP ADAPTOR
4	A-ES12-0471	1	COUPLING HALF (MOTOR SIDE)
5	NPN	1	CUP POINT SET SCREW, 5/16-18 UNC X .375
6	NPN	1	SQUARE KEY, 1/4 X 1.25 LG
7	A-ES12-0470-1	1	COUPLING HALF (PUMP SIDE)
8	NPN	1	SQUARE KEY, 5/64 X 1.25 LG
9	A-ES12-0472	1	COUPLING SPIDER
10	NPN	6	HCS, 3/8-16 UNC X 1
11	NPN	6	LOCK WASHER, 3/8

Hydraulic Pump Assembly

This applies to unit S/N's: 12E105 through 12E111 and 12E113 only (unless retrofit for AC Pump).

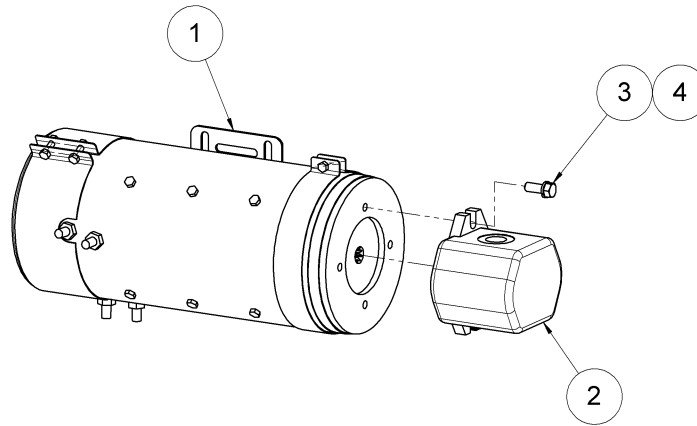

Item	Part Number	Qty.	Description
1	A-ES12-0475-1	1	DC HYDRAULIC MOTOR
2	A-ES12-0450-1	1	GEAR PUMP
3	NPN	2	HCS, 3/8-24 UNF X 1
4	NPN	2	LOCK WASHER, 3/8

Hydraulic Pump Assembly

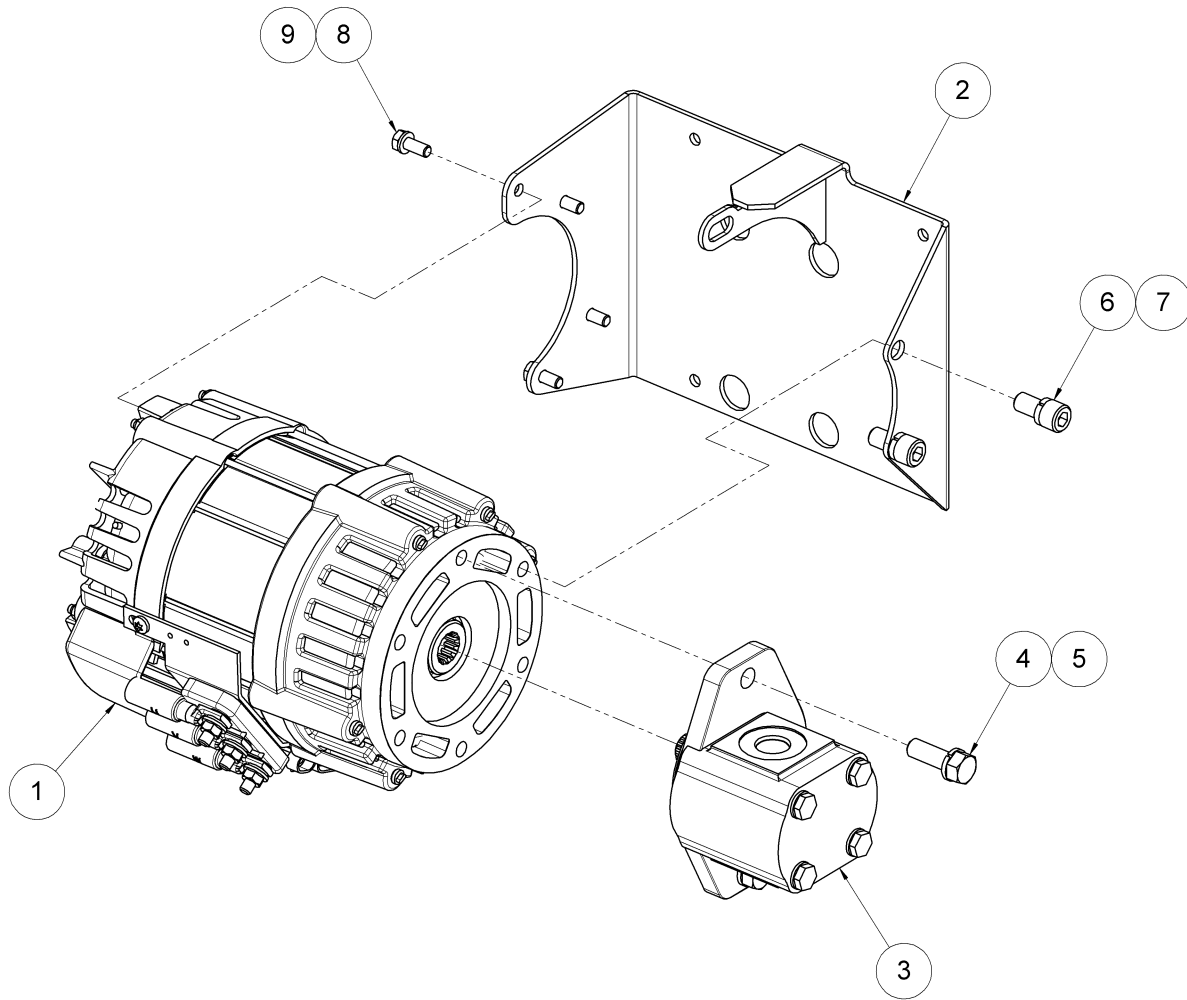

Item	Part Number	Qty.	Description
1	A-ES12-0475-2	1	AC HYDRAULIC MOTOR
2	A-ES12-0201	1	MOTOR MOUNT
3	A-ES12-0450-2	1	GEAR PUMP
4	NPN	2	HCS, 1/2-13 UNC X 1.5
5	NPN	2	LOCK WASHER, 1/2
6	NPN	2	SCS, 1/2-13 UNC X 1
7	NPN	2	HI-COLLAR LOCK WASHER, 1/2
8	NPN	4	HCS, M8X1.25 X 20
9	NPN	4	LOCK WASHER, M8

Manifold Pressure Switches

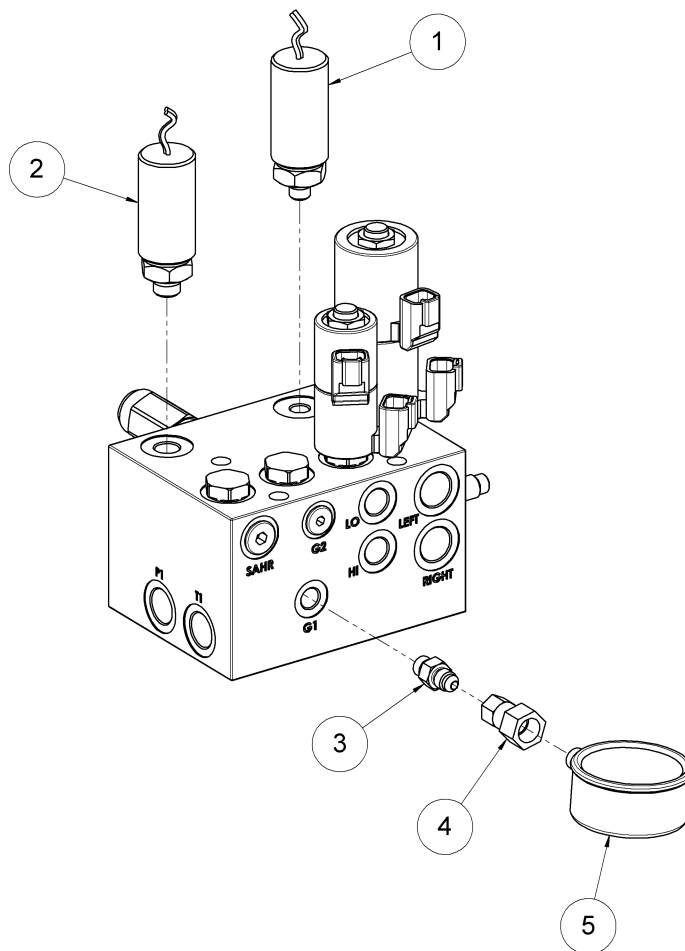

Item	Part Number	Qty.	Description
1	A-ETT8-0455*	1	LOW PRESSURE SWITCH, 1800 F
2	A-ETT8-0456*	1	HIGH PRESSURE SWITCH, 2500 R
3	C5315X4	1	ADAPTOR - 4 SAE ORB M - 4 JIC M
4	C5256X4X4	1	ADAPTOR - .25 F NPT - .25 F JIC SWIVEL
5	A-ES12-0463-1	1	2.5 IN PRESSURE GAGE

* For eTT12 and eTT16 tractors manufactured before June, 2011, replacement switch must be selected to match pressure rating etched on currently installed pressure switch. Non-production service parts listed below.

Part Number	Description
A-ES12-0455-2	LOW PRESSURE SWITCH, 2200 F
A-ES12-0456-2	HIGH PRESSURE SWITCH, 2900 R

Hydraulic Manifold Assembly

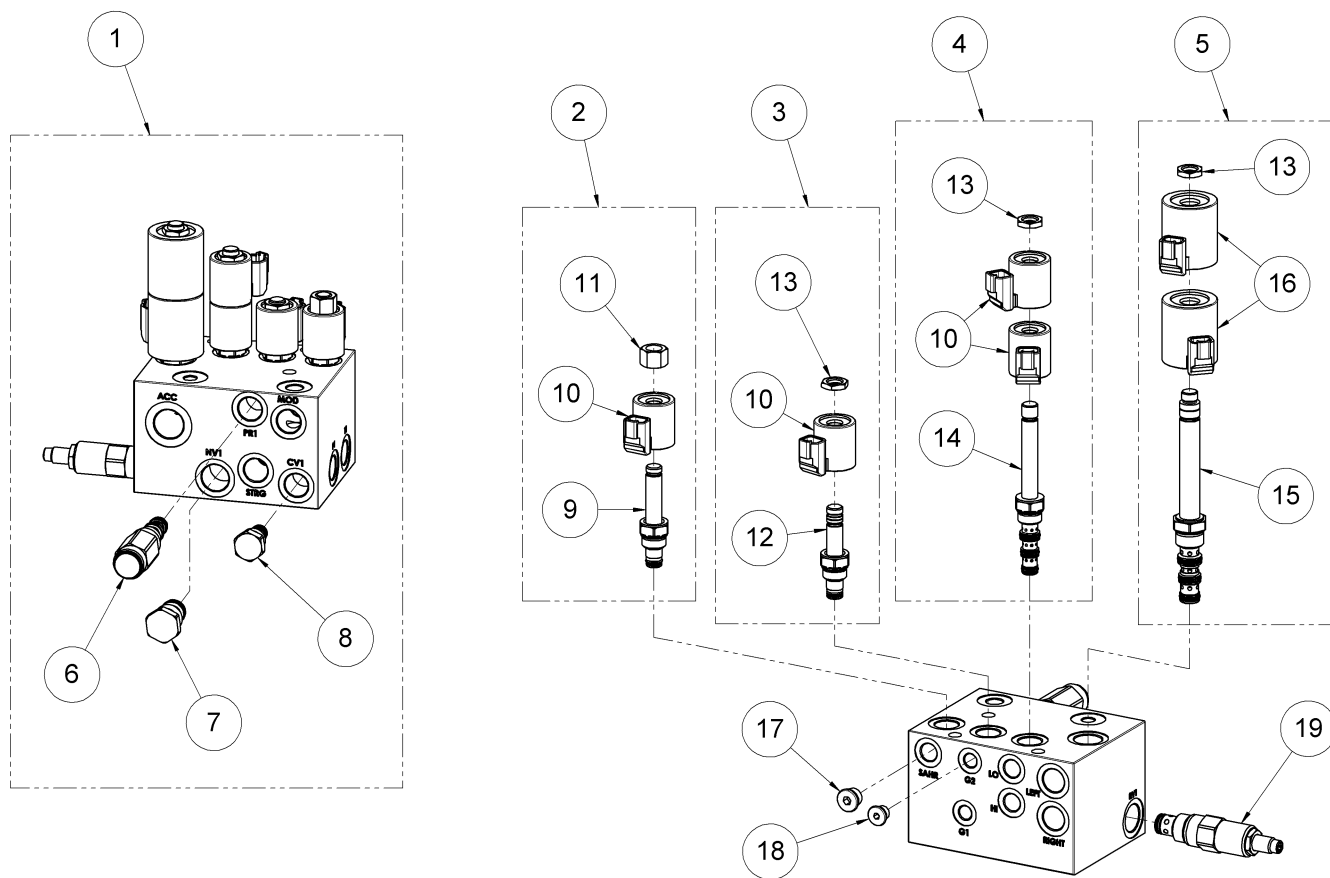

Item	Part Number	Qty.	Description
1	A-ES12-0479-2	1	MANIFOLD BLOCK ASSEMBLY COMPLETE
2	ET00-59-008-CA	1	SAHR VALVE A (N.O.) COMPLETE
3	ET00-59-009-CA	1	SAHR VALVE B (N.C.) COMPLETE
4	ET00-59-001-CA	1	SHIFT VALVE COMPLETE
5	ET00-59-002-CA	1	STEER VALVE COMPLETE
6	A-ES12-PR58-38	1	PRESSURE REDUCING VALVE - 250 PSI
7	ET00-59-003-CA	1	CAVITY PLUG (REPLACES NEEDLE VALVE)
8	A-ES12-CV08-20	1	CHECK VALVE
9	ET00-59-006-CA	1	SAHR VALVE A, N.O., VALVE ONLY
10	A-ES12-4303624	4	SHIFT COIL, 24V
11	ET00-59-007-CA	1	COIL NUT
12	ET00-59-005-CA	1	SAHR VALVE B, N.C., VALVE ONLY
13	A-ES12-7004400	3	COIL NUT
14	A-ES12-SV08-47D	1	SHIFT VALVE (VALVE ONLY)
15	A-ES12-SP10-476	1	STEER VALVE (VALVE ONLY)
16	A-ES12-4303724	2	STEER COIL, 24 V
17	NPN	1	-6 SAE ORB PLUG
18	NPN	1	-4 SAE ORB PLUG
19	A-ES12-RV10-20	1	RELIEF VALVE

Manifold Schematic

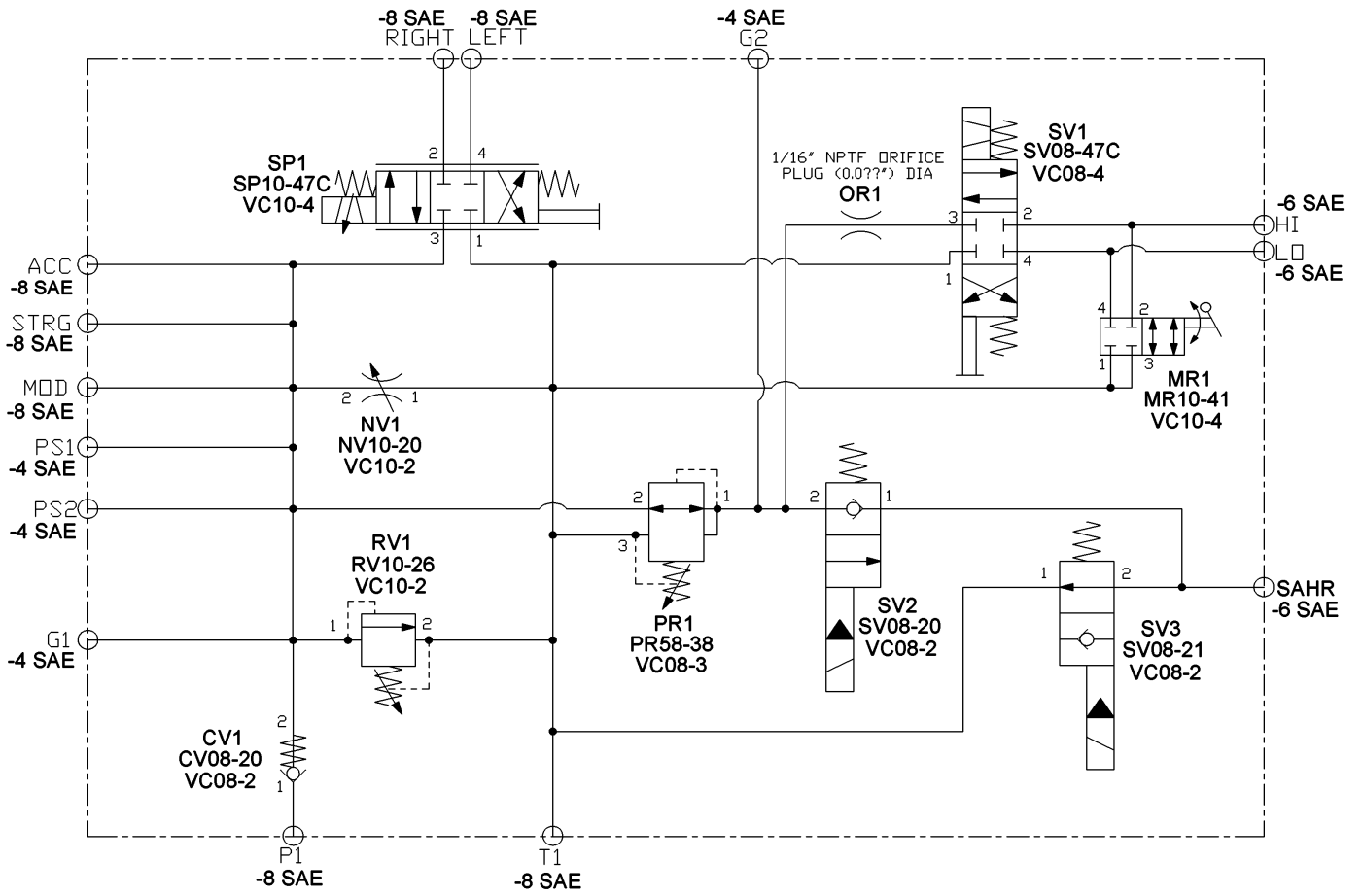

Hydraulic Manifold Assembly

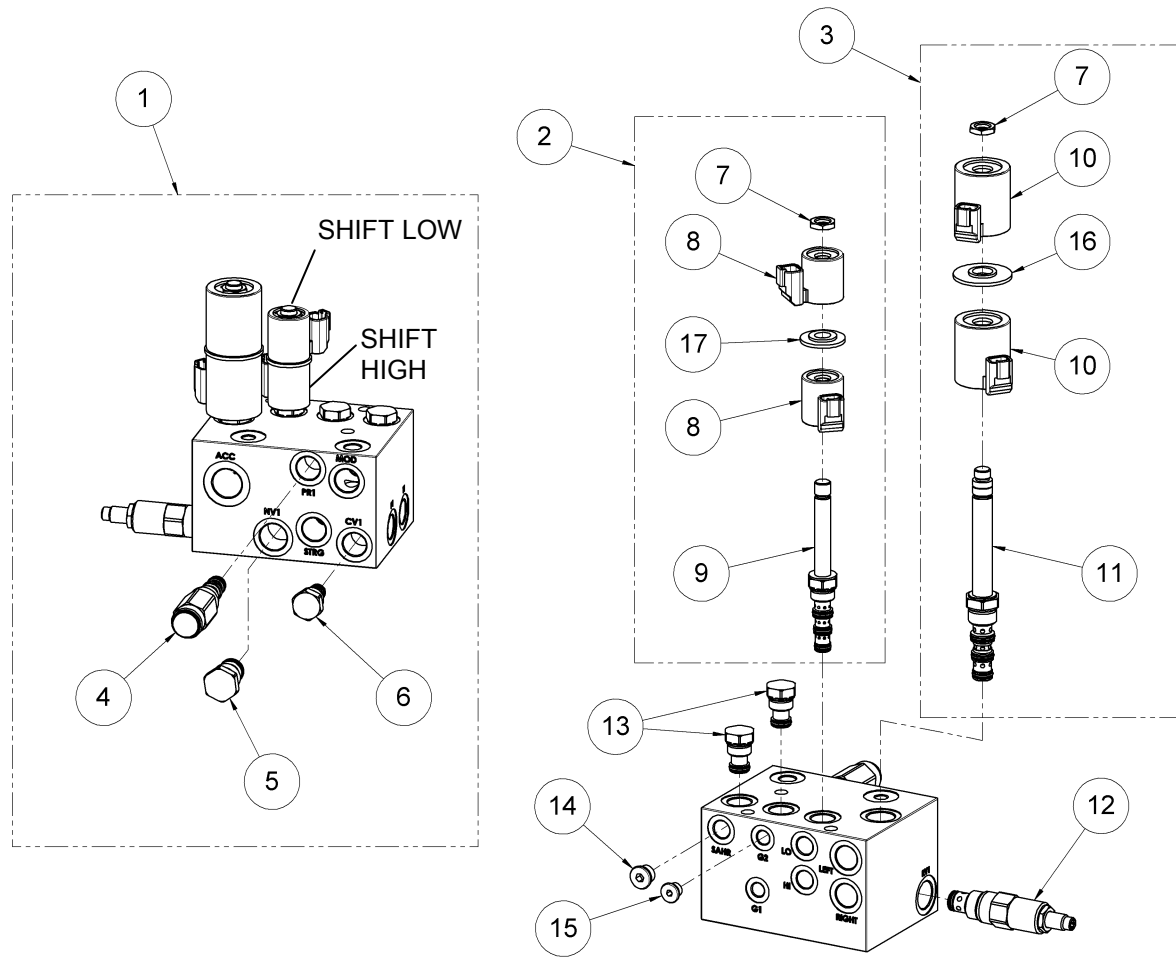

Item	Part Number	Qty.	Description
1	A-ES12-0479-2	1	MANIFOLD BLOCK ASSEMBLY COMPLETE
2	ET00-59-001-CA	1	SHIFT VALVE COMPLETE
3	ET00-59-002-CA	1	STEER VALVE COMPLETE
4	A-ES12-PR58-38	1	PRESSURE REDUCING VALVE - 250 PSI
5	ET00-59-003-CA	1	CAVITY PLUG (REPLACES NEEDLE VALVE)
6	A-ES12-CV08-20	1	CHECK VALVE
7	A-ES12-7004400	2	COIL NUT
8	A-ES12-4303624	2	SHIFT COIL, 24V
9	A-ES12-SV08-47D	1	SHIFT VALVE (VALVE ONLY)
10	A-ES12-4303724	2	STEER COIL, 24 V
11	A-ES12-SP10-476	1	STEER VALVE (VALVE ONLY)
12	A-ES12-RV10-20	1	RELIEF VALVE
13	ET00-59-004-CA	2	CAVITY PLUG
14	NPN	1	-6 SAE ORB PLUG
15	NPN	1	-4 SAE ORB PLUG
16	A-ES12-4539700	1	COIL SPACER, 8 SIZE
17	A-ES12-4534720	1	COIL SPACER, 10 SIZE

Manifold Schematic

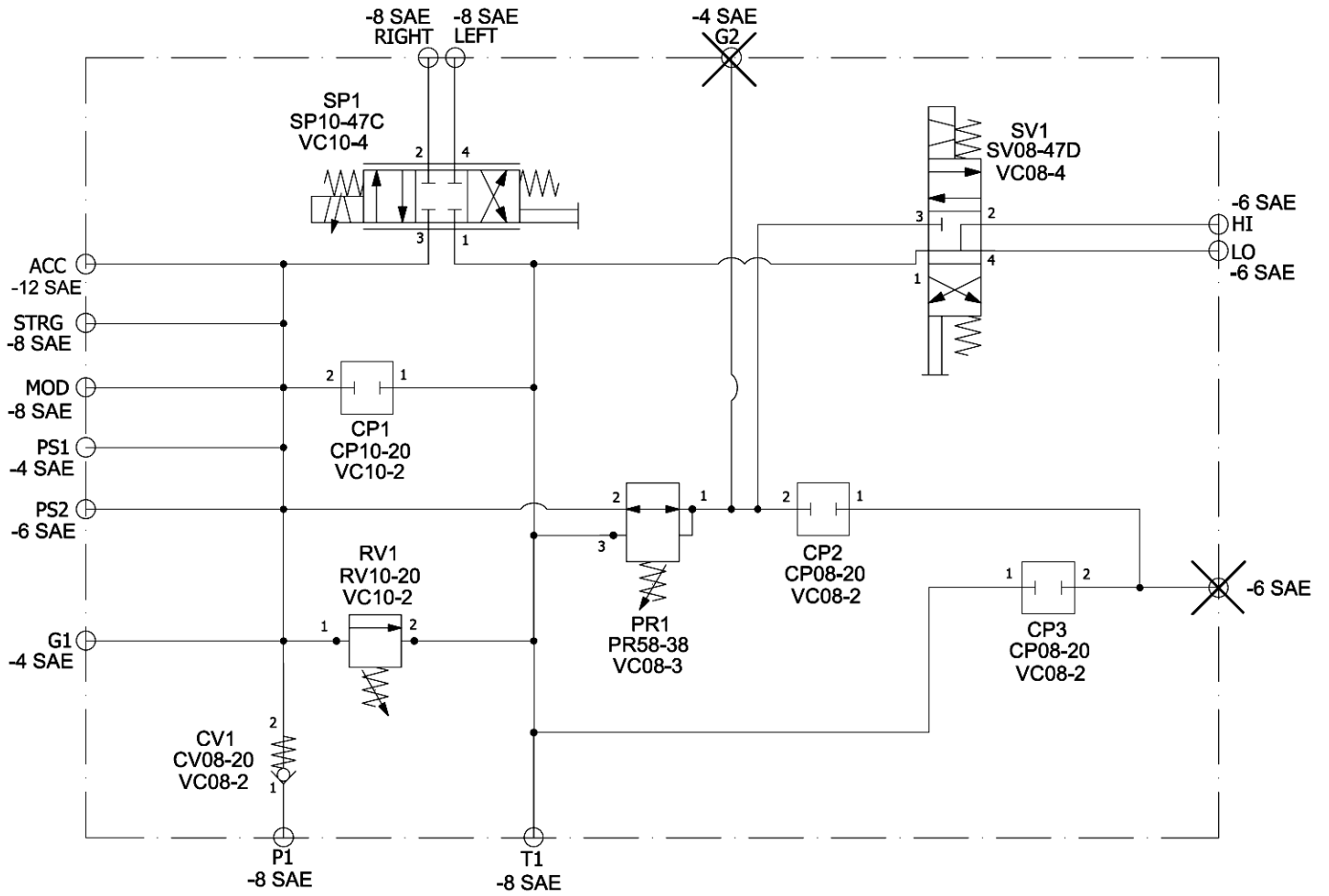

Hydraulic Manifold Assembly

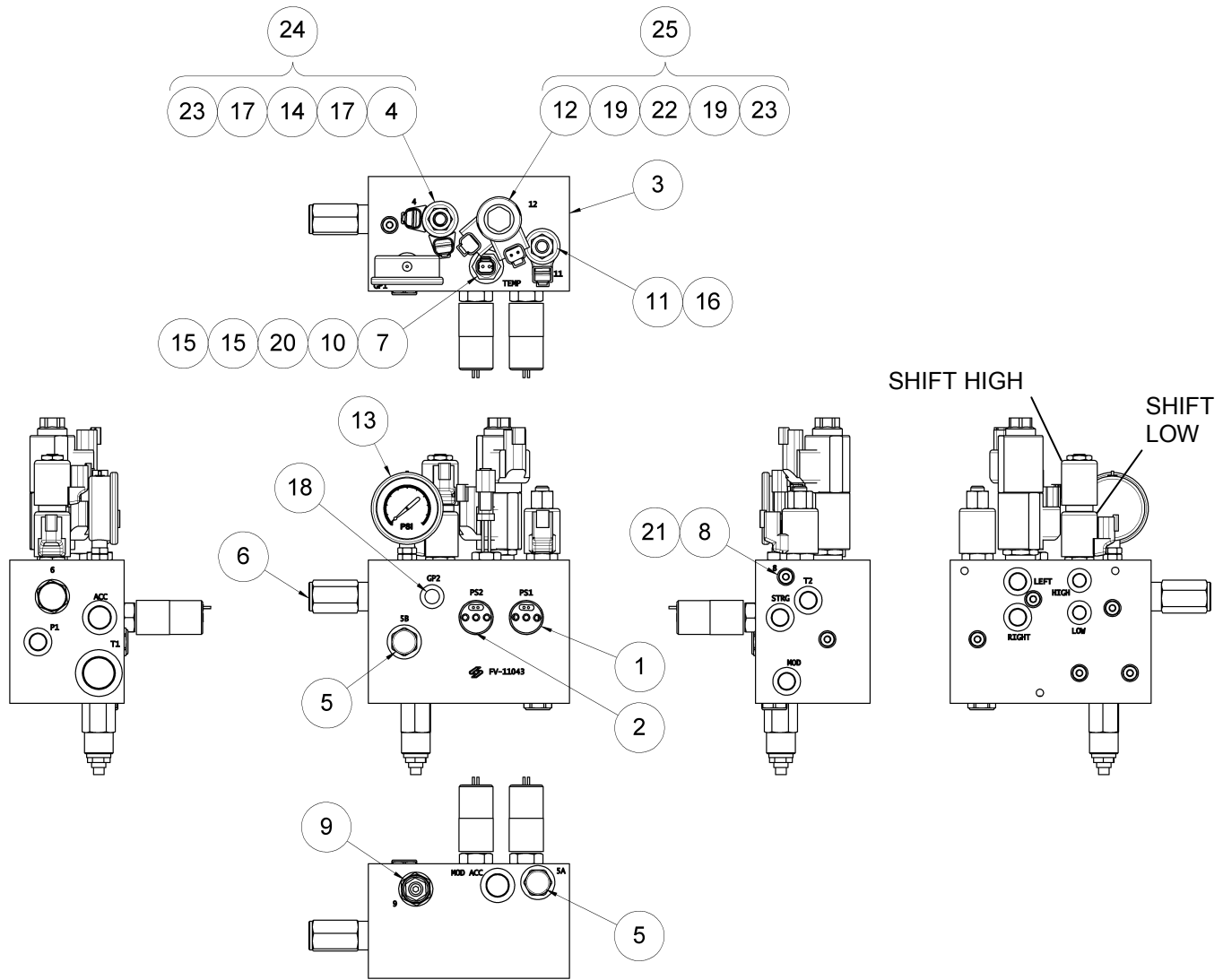

Item	Part Number	Qty.	Description
N/S	ET00-09-001-SA	1	HYDRAULIC MANIFOLD ASSEMBLY - CONTAINS ITEMS 1 THRU 25
1	A-ETT8-0455	1	LOW PRESSURE SWITCH, 1800 F
2	A-ETT8-0456	1	HIGH PRESSURE SWITCH, 2500 R
3	NOT AVAILABLE	1	VALVE BODY (NOT AVAILABLE SEPARATELY)
4	A-ES12-SV08-47D*	1	SHIFT VALVE ONLY
5	XL00-59-003-CA	2	CHECK VALVE
6	ET00-59-013-CA	1	PRESSURE REDUCING VALVE, ETTG
7	ET00-59-014-CA	1	TEMP SWITCH, 160°F - REQUIRES ITEMS 10,20 (QTY:1), 15 (QTY:2)
8	ET00-59-015-CA	1	REMOVABLE ORIFICE, ETTG
9	ET00-59-016-CA	1	RELIEF VALVE, 3000PSI, ETTG
10	DT04-2P	1	ELECTRICAL CONNECTOR
11	ET00-59-017-CA	1	BLEED VALVE, ETTG
12	A-ES12-SP10-476	1	STEER VALVE ONLY
13	ET00-59-019-CA	1	PRESSURE GAUGE, 3000PSI
14	A-ES12-4534720*	1	COIL SPACER, 8 SIZE
15	0460-202-16141	2	CONNECTOR PIN

Manifold Schematic

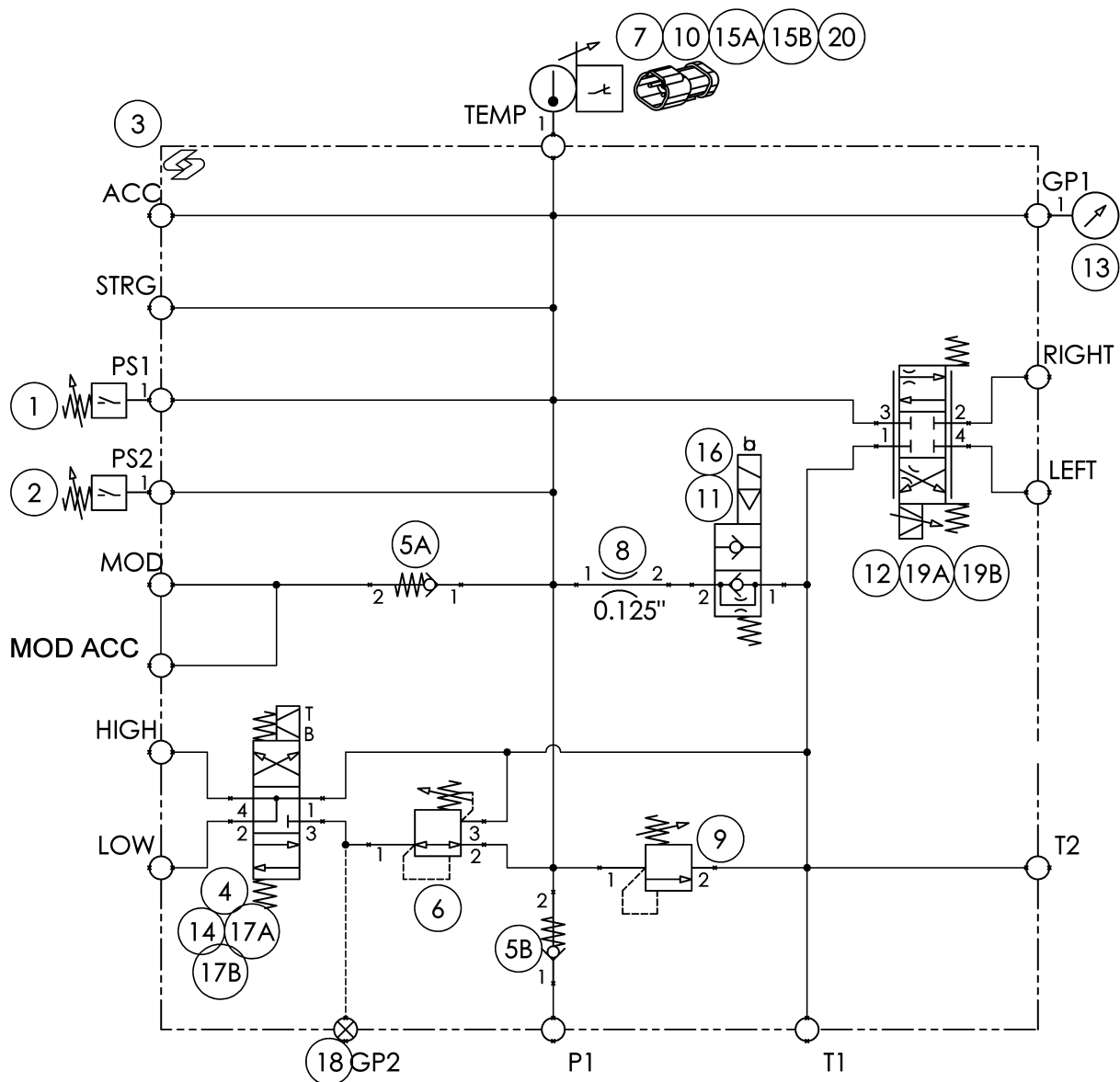

Item	Part Number	Qty.	Description
16	ET00-59-021-CA	1	COIL, 12V
17	A-ES12-4303624*	2	SHIFT COIL, 24V
18	7237X4	1	HEX PLUG, 4 SAE ORB
19	A-ES12-4303724	2	STEER COIL, 24V
20	W2P	1	CONNECTOR LOCK
21	XL00-59-027-CA	8	PLUG, 4 SAE ORB
22	A-ES12-4539700	1	COIL SPACER, 10 SIZE
23	A-ES12-7004400*	2	COIL NUT
24	ET00-59-001-CA*	1	SHIFT VALVE COMPLETE
25	ET00-59-002-CA	1	STEER VALVE COMPLETE

*Some tractors manufactured between February 2017 and May 2018 were built with shift valve assemblies that are not compatible with the separate pieces listed above. For replacement of these valve assemblies, the whole valve assembly (Item 24) must be ordered and replaced.

This page intentionally left blank.

Manifold Assembly With Filter and Accumulator

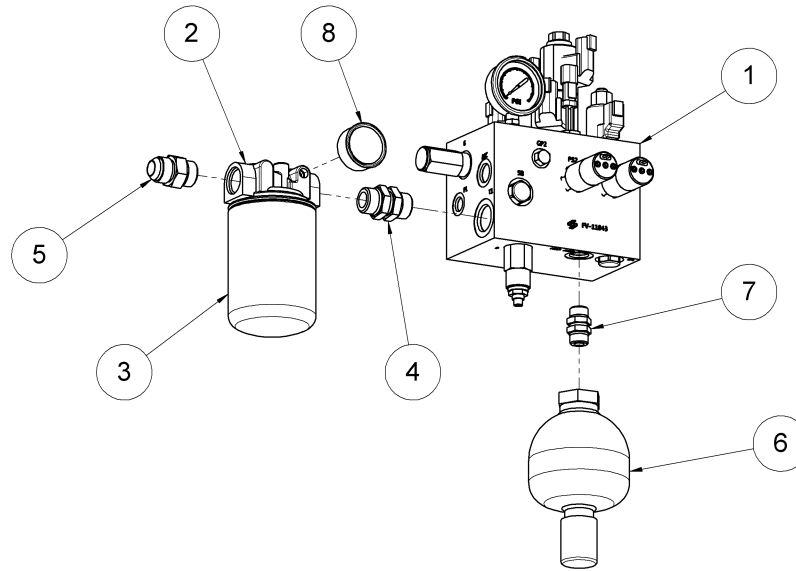

Item	Part Number	Qty.	Description
1	N/A	-	MANIFOLD ASSEMBLY (SEE PREVIOUS PAGES FOR P/N)
2	A-ES12-0486	1	FILTER HEAD
3	A-ES12-0485	1	FILTER ELEMENT
4	C5314X12X12	1	ADAPTER - 12 SAE ORB M
5	C5315X12	1	ADAPTER - 12 SAE ORB M, - 12 JIC M
6	A-MTT5-0453	1	ACCUMULATOR, .5L
7	C5314X8X8	1	ADAPTER - 8 SAE ORB M
8	A-ES12-0487	1	INDICATOR, FILTER BACKPRESSURE

Brake Pedal Assembly

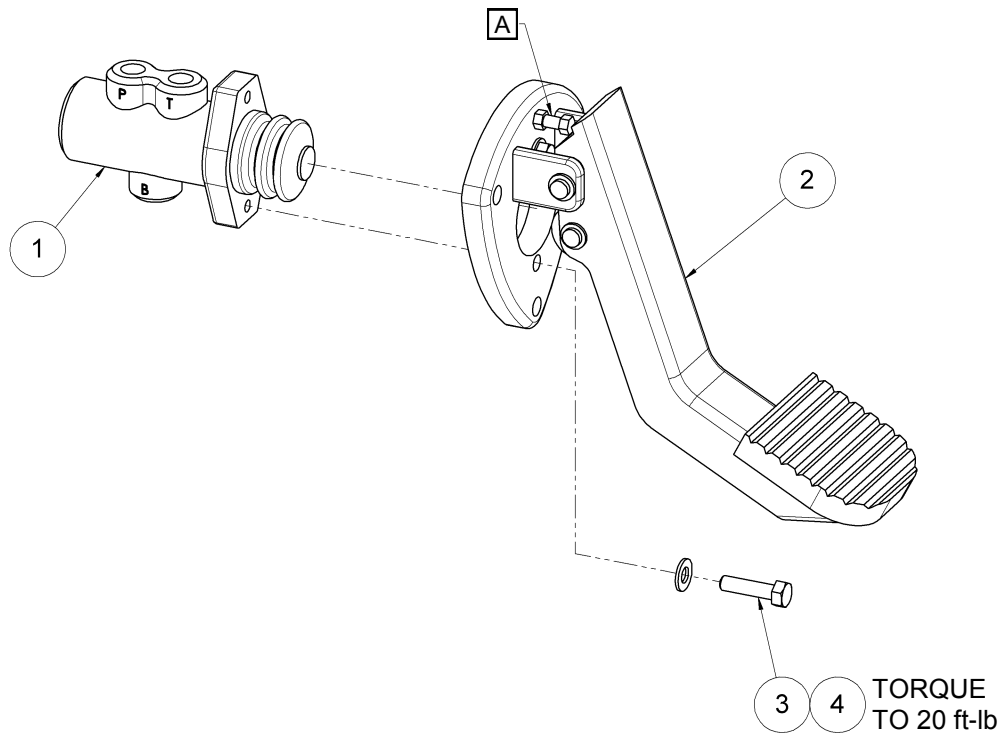

A Travel screw must be adjusted for minimum pre-travel of the brake pedal without compressing the main valve spring and moving the valve body.

Item	Part Number	Qty.	Description
1	A-ES12-0460-2	1	BRAKE PRESSURE MODULATING VALVE
2	A-ES12-0481	1	BRAKE PEDAL ASSEMBLY
3	NPN	2	HCS, 5/16-18 UNC X 1.0, GR8, ZN PLATED
4	NPN	2	FLAT WASHER, 5/16

Cooler Assembly

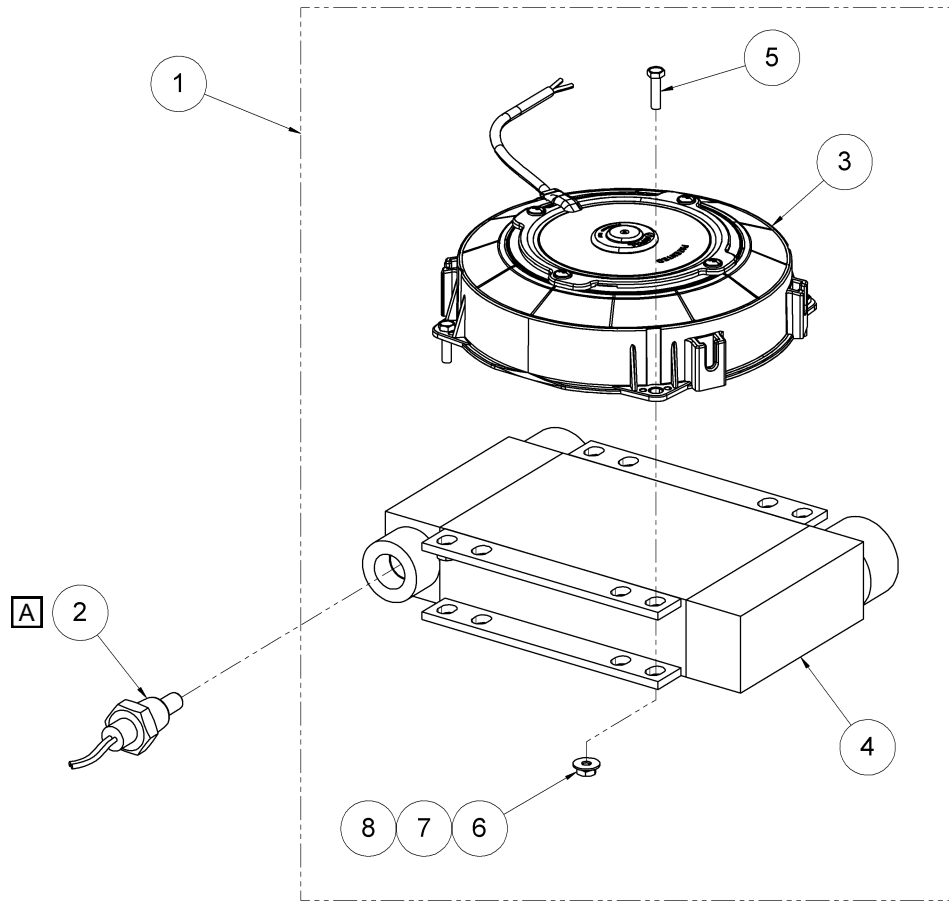

A The cooler assembly should be assembled so that the temp switch is in-line with the intake flow. Verify based on tractor hose routing and re-assemble if necessary.

Item	Part Number	Qty.	Description
1	A-ES12-0564	1	COOLER ASSEMBLY (CORE AND FAN)
2	ET00-08-001-CA	1	TEMP SWITCH (ORB) - FOR UNITS BUILT JULY 2013 AND LATER
2	A-ES12-0565	1	TEMP SWITCH (NPT) - FOR UNITS BUILT BEFORE JULY 2013
3	ET00-58-001-CA	1	COOLING FAN
4	ET00-58-002-CA	1	COOLER CORE
5	NPN	4	HCS, #10-32 UNC X .75
6	NPN	4	FLAT WASHER, #10
7	NPN	4	LOCK WASHER, #10
8	NPN	4	HEX NUT, #10-32 UNC
N/A	DT04-4P	1	ELECTRICAL CONNECTOR (INSTALLED TO ITEMS 2 AND 3)
N/A	W4P	1	CONNECTOR LOCK (INSTALLED TO ITEMS 2 AND 3)
N/A	0460-215-16141	4	CONNECTOR PINS (INSTALLED TO ITEMS 2 AND 3)

Items 2 and 3 to be wired as shown below:

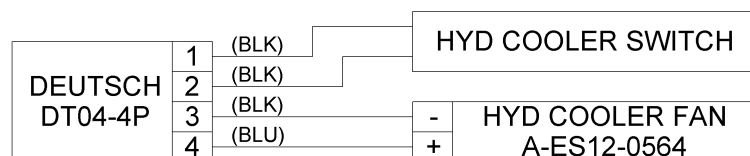

Return Filter Assembly

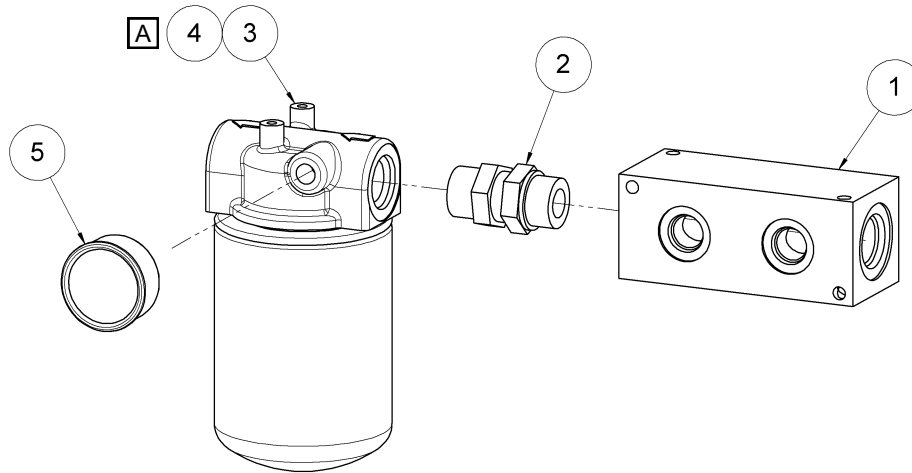

A Flow direction should be away from the return manifold block.

Item	Part Number	Qty.	Description
1	A-MTT5-0450	1	DRAIN MANIFOLD
2	C5314X12X12	1	ADAPTOR - 12 SAE ORB - 12 SAE ORB
3	A-ES12-0486	1	HYDRAULIC FILTER HEAD ASSEMBLY
4	A-ES12-0485	1	HYDRAULIC FILTER ELEMENT
5	A-ES12-0487	1	FILTER BACKPRESSURE GAGE

Tank Assembly

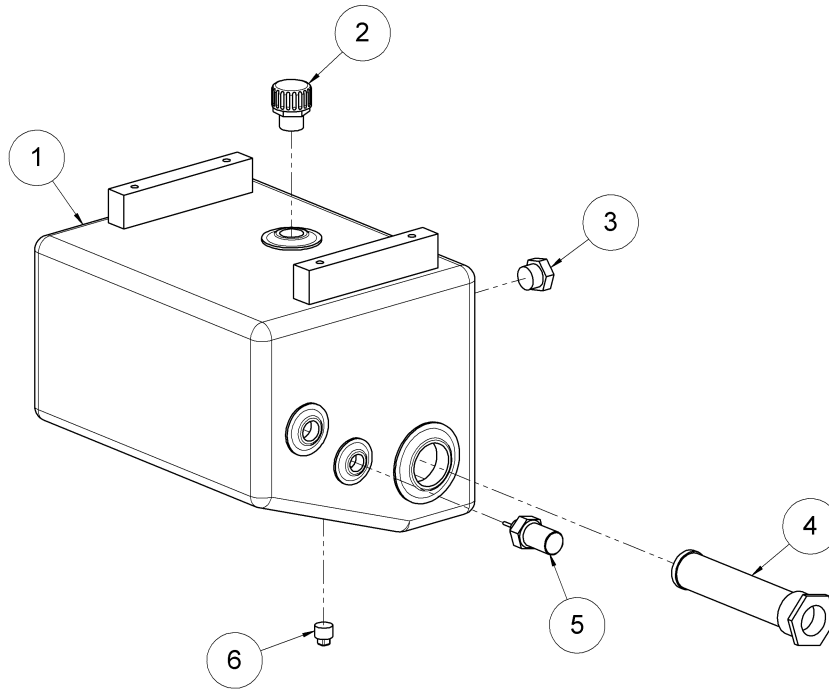

eTT8/eTT12/eTT16 TOP MOUNT

eTT8/eTT12
FRONT/REAR MOUNT

eXL16 RIGHT/TOP MOUNT

Item	Part Number	Qty.	Description
1	A-ETT8-0469	1	ETT8, HYDRAULIC TANK, FRONT/REAR MOUNT
1	A-ETT8-0469-1	1	ETT8, HYDRAULIC TANK, TOP MOUNT
1	A-ES12-0469-1	1	ETT12, HYDRAULIC TANK, FRONT/REAR MOUNT
1	A-ES12-0469-2	1	ETT12/ETT16, HYDRAULIC TANK, TOP MOUNT
1	A-EXL16-0469	1	ETT16, HYDRAULIC TANK, RIGHT/TOP MOUNT
2	A-ES12-0550	1	HYDRAULIC FILLER CAP
3	A-ES12-0551	1	HYDRAULIC SIGHT GAUGE
4	A-ES12-0488	1	HYDRAULIC TANK STRAINER
5	A-ES12-0484-1	1	HYDRAULIC TEMP SWITCH (NOT PRESENT ON ALL TRACTORS)
5	C3159X8	1	PLUG, 1/2 NPT (NOT PRESENT ON ALL TRACTORS)
6	A-ES12-0552	1	MAGNETIC DRAIN PLUG

Revision Log

Rev	Date	Description	Appr.
A	21-Feb-2014	Original release for production	PRB
B	04-Sep-2014	Corrected typographical errors	SEB
C	09-Feb-2014	Added schematics for manifolds. Updated for eTT rev G tractors	SEB
D	14-Apr-2015	Revised model information for Tank Assembly. Corrected Hyd Tank Part Number.	DCM
E	20-May-2015	Application serial number range updated to reflect production sequencing. Removed obsolete information for DC Hydraulic Pump for eTT8 tractors. Added non-production service part numbers for pressure switches. Clarified shift solenoid positions.	DCM
F	20-Oct-2015	Added coil spacers and corrected steer valve and coil part numbers for hydraulic manifold assembly.	DCM
G	6-Jun-2016	Changed eXL16 model name to eTT16	TFP
H	22-May-2017	Updated Shift and Steering Valve part numbers on G units.	SEB

Table of Contents

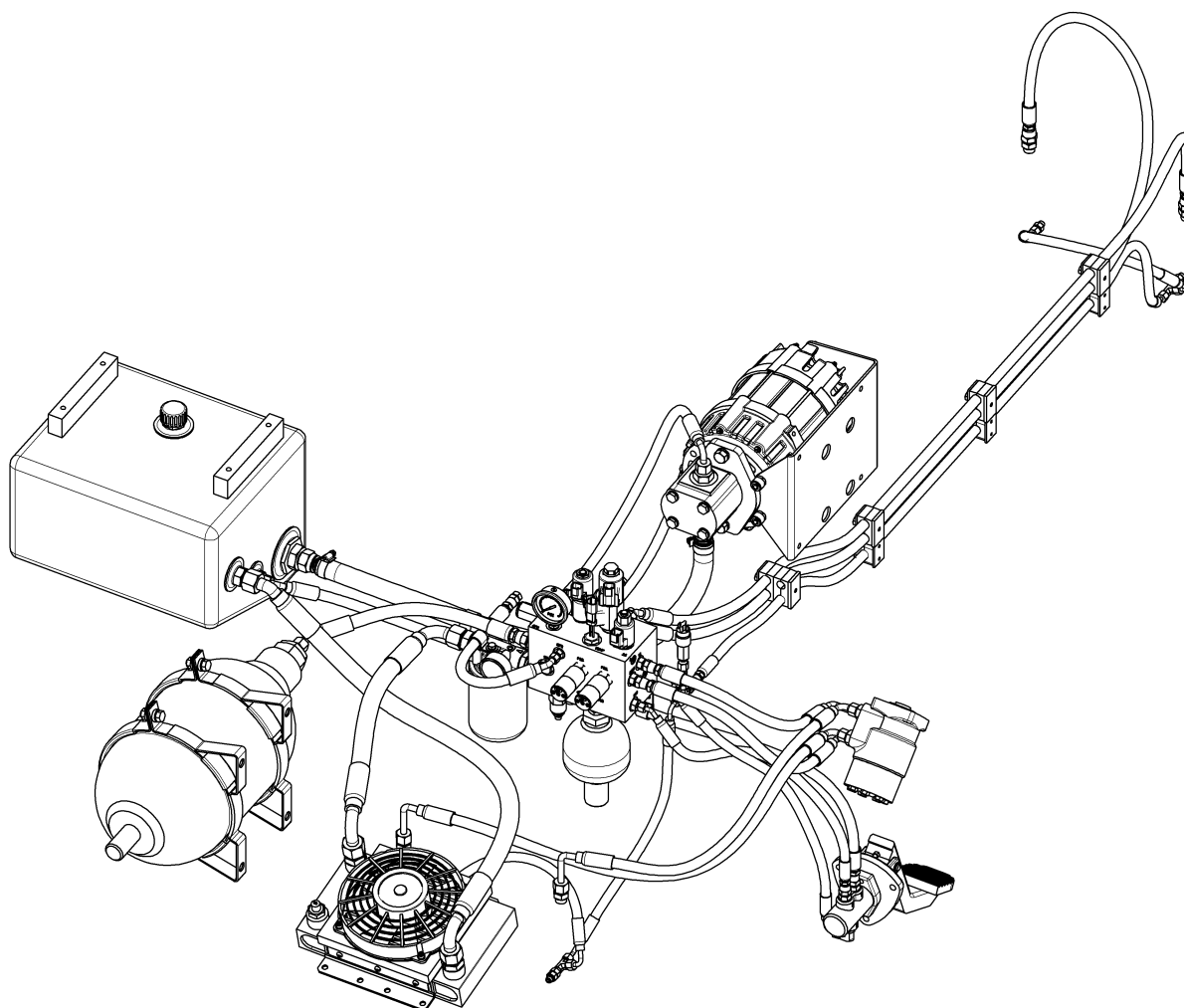

Section 7 - Hydraulic System

Description	Page
Hydraulic Diagram	7-2
Brake Pedal Installation	7-11
Steering and Brake Hoses	7-12
Hydraulic Cooler Installation and Hoses	7-14
Hydraulic Tank and Pump Installation	7-16
Main Accumulator Installation and Hoses	7-20
Brake Accumulator Installation and Hoses	7-22
Return Filter Assembly Installation and Hoses	7-23
Manifold Installation and Hoses	7-24
Axle Hoses	7-28
Revision Log	7-30

Hydraulic Hose Diagram

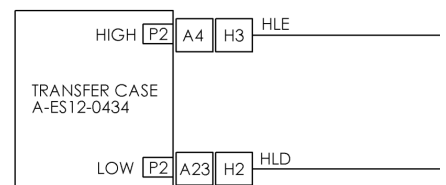
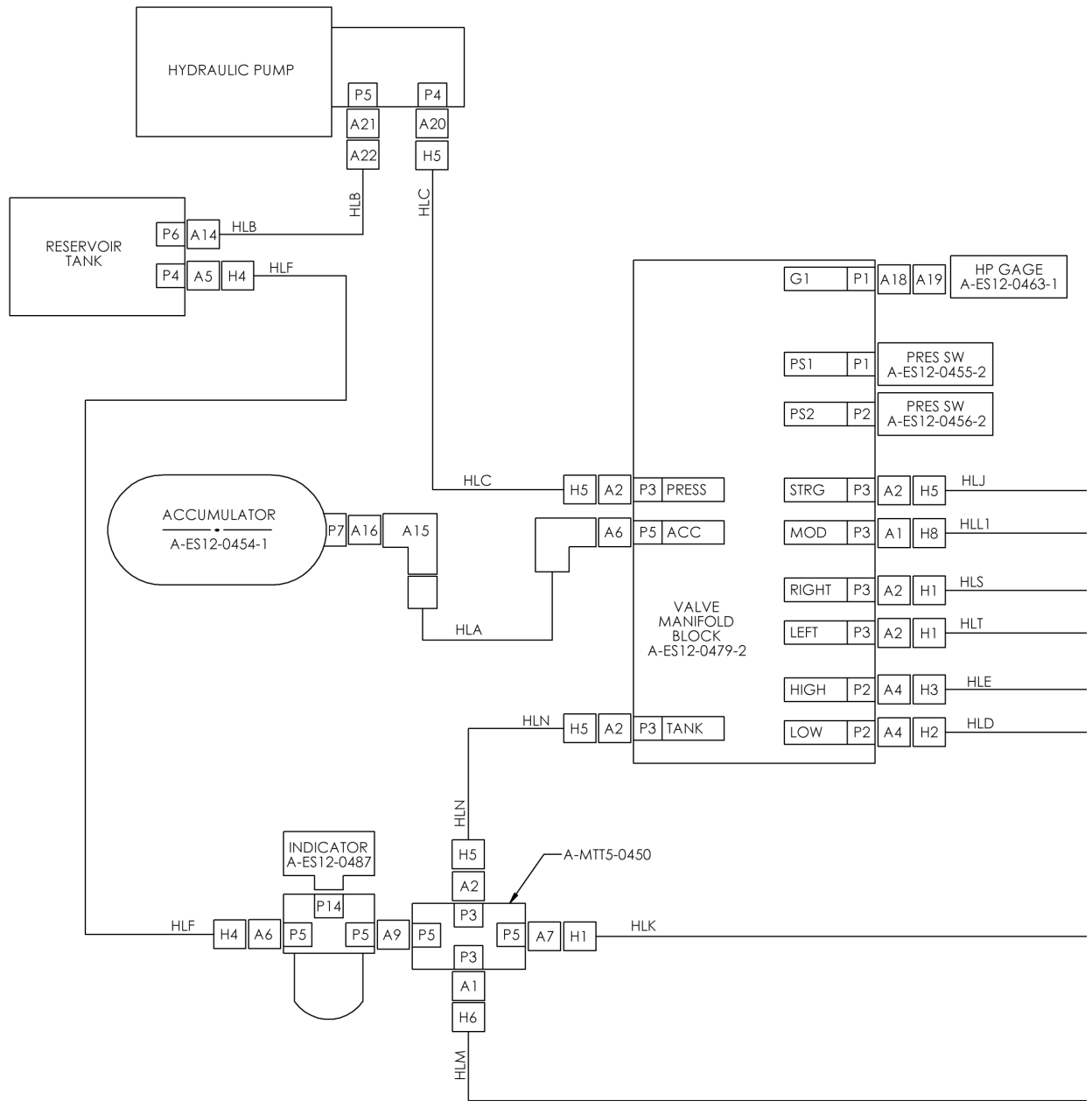

Hydraulic Hose Diagram

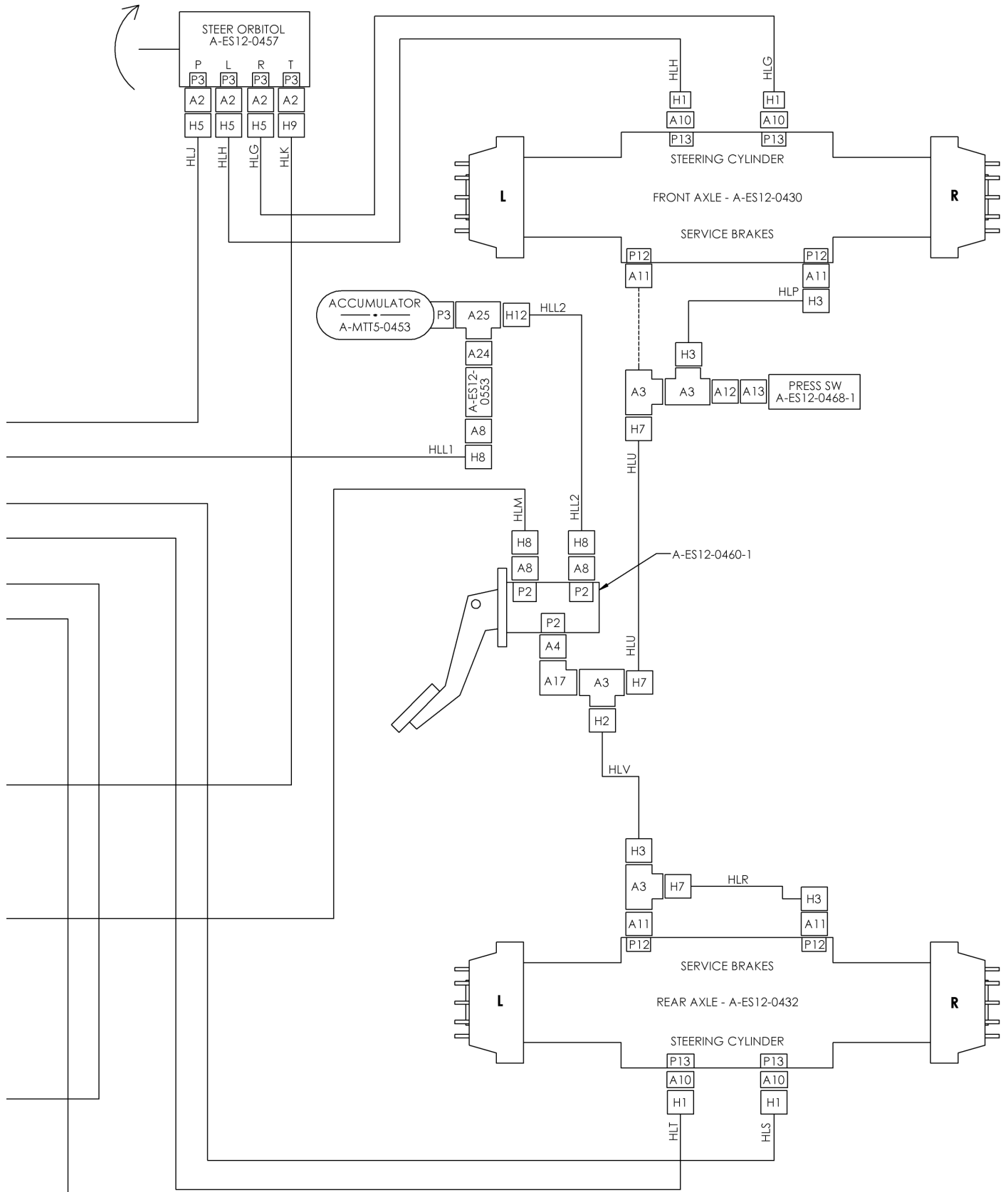

Hydraulic Hoses

Item	Part Number End A - Length - End B	Hose	Description
HLA	12U-616-9.5-12U-652	H14512	ACCUMULATOR
HLB	12GMV, 32	12 GMV	3/4" SUCTION HOSE X 32" LONG
HLC	08U-668-26-08U-668	H14508	PUMP PRESSURE
HLD	04U-604-28-04U-604	H42504	SHIFT - LOW
HLE	04U-684-11.5-04U-684	H42504	SHIFT - HIGH
HLFA	12U-672-23-12U-612	H14512	COOLER INLET
HLFB	12U-612-29-12U-612	H14512	COOLER OUTLET
HLG	08U-668-36-08U-608	H14508	FRONT STEER - R
HLH	08U-668-26-08U-608	H14508	FRONT STEER - L
HL J	08U-668-20-08U-668	H14508	STEER PRESSURE
HLK	08U-648-23-08U-608	H14508	STEER RETURN
HLL1	06U-606-23-06U-606	H14506	BRAKE ACCUMULATOR - CHARGE
HLL2	06U-608-36-06U-606	H14506	BRAKE PRESSURE
HLM	06U-606-34-06U-666	H14506	BRAKE RETURN
HLN	08U-668-18-08U-668	H14508	MANIFOLD RETURN
HLP	04U-684-17-04U-684	H42504	FRONT BRAKE JUMPER
HLR	04U-664-15-04U-684	H42504	REAR BRAKE JUMPER
HLS	08U-608-92-08U-608	H14508	REAR STEER - R
HLT	08U-608-75-08U-608	H14508	REAR STEER - L
HLU	04U-664-20.5-04U-664	H42504	FRONT BRAKE
HLV	04U-604-86.5-04U-684	H42504	REAR BRAKE

Hydraulic Fittings

Item	Part Number	Qty.	Description
A1	C5315X6X8	2	ADAPTOR - 8 SAE ORB M - 6 JIC M
A2	C5315X8	10	ADAPTOR - 8 SAE ORB M - 8 JIC M
A3	C5706X4	4	TEE - 2X 4 JIC M - 4 JIC F
A4	C5315X4X6	4	ADAPTOR - 6 SAE ORB M - 4 JIC M
A5	C5315X12X10	1	ADAPTOR - 10 SAE ORB M - 12 JIC M
A6	C5315X12	2	ADAPTOR - 12 SAE ORB M - 12 JIC M
A7	C5315X8X12	1	ADAPTOR - 12 SAE ORB - 8 JIC M
A8	C5315X6	3	ADAPTOR - 6 SAE ORB M - 6 JIC M
A9	C5314X12X12	1	ADAPTOR - 12 SAE ORB M - 12 SAE ORB M
A10	MC5315X8X18	4	ADAPTOR - M18x1.5 DIN M - 8 JIC M
A11	MC5315X4X10	4	ADAPTOR - M10x1.0 DIN M - 4 JIC M
A12	C5216X4X4	1	ADAPTOR - 4 SAE ORB M - 4 JIC F
A13	4G5HG5-S	1	ADAPTOR - 4 SAE ORB F - 4 SAE ORB F
A14	C5315X12X16	1	ADAPTOR - 16 SAE ORB M - 12 JIC M
A15	TF5515X16X20	1	ELBOW, 90° - 20 SAE M - 16 JIC M
A16	7033X24X20	1	ADAPTOR - 24 SAE ORB M - 20 SAE ORB F
A17	C5506X4	1	ELBOW, 90° - 4 JIC M - 4 JIC F
A18	C5315X4	1	ADAPTOR - 4 SAE ORB M - 4 JIC M
A19	C5256X4X4	1	ADAPTOR - 4 JIC F - .25 NPT F
A20	C5315X8X10	1	ADAPTOR - 10 SAE ORB M - 8 JIC M
A21	C5315X12X10	1	ADAPTOR - 10 SAE ORB M - 12 JIC M
A22	30682-12-12	2	ADAPTOR - 12 JIC F - .75 BARB
A23	C5515X4X6	1	ELBOW, 90° - 6 SAE ORB M - 4 JIC M
A24	C5216X8X6	1	ADAPTOR - 6 SAE ORB M - 8 JIC F
A25	C5716X8	1	ADAPTOR - 8 SAE ORB M - 2X 8 JIC M
A26	8 AOG5JG5-S	1	RUN TEE - 8 SAE ORB
A27	C3159X8	1	HEX PLUG - .50 NPT
A28	A-ES12-0550	1	FILLER CAP
A29	A-ES12-0488	1	SUCTION STRAINER
A30	A-ES12-0551	1	SIGHT GAUGE
A31	A-ES12-0552	1	MAGNETIC DRAIN PLUG

Hydraulic Hose Diagram

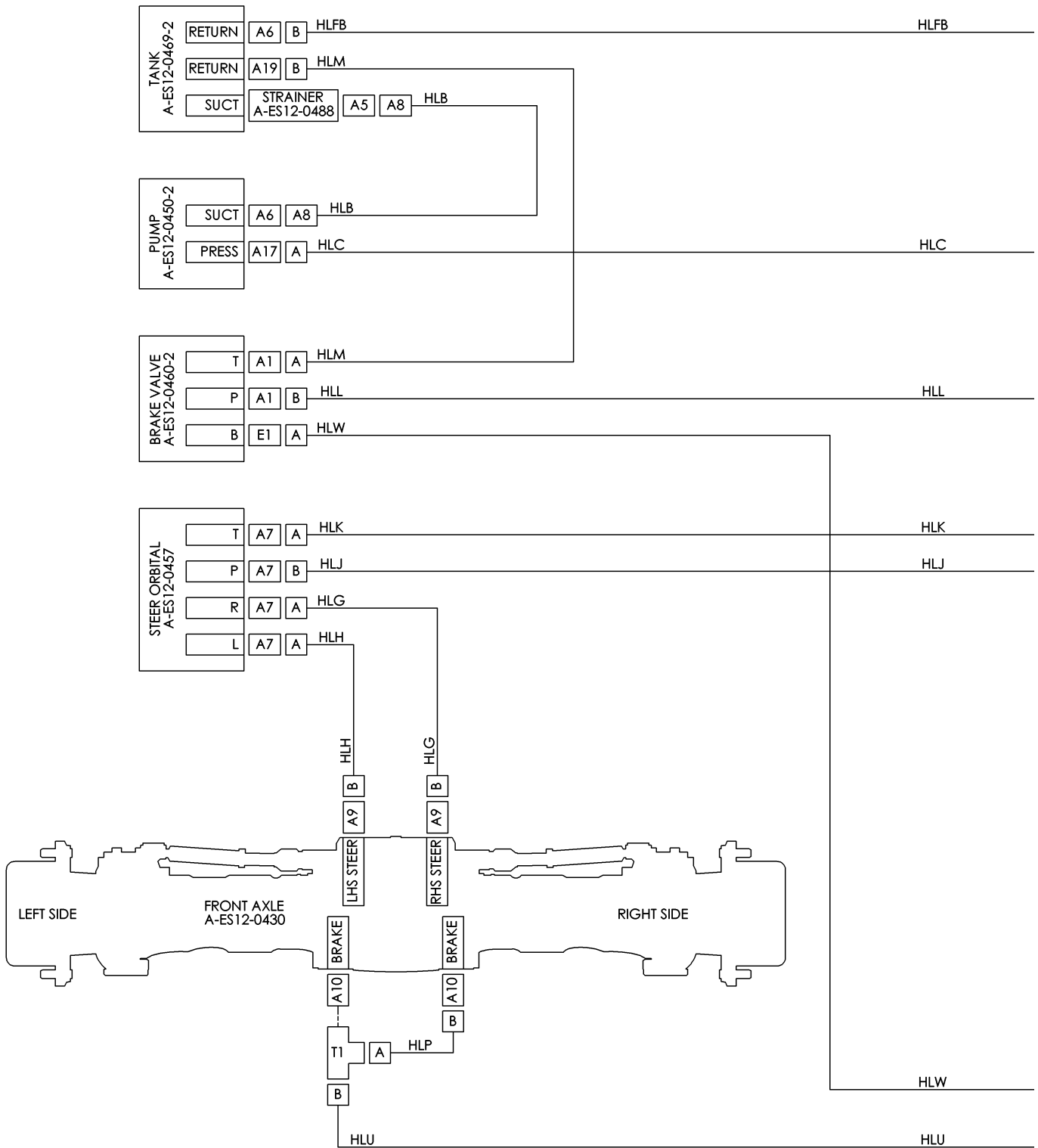

Hydraulic Hose Diagram

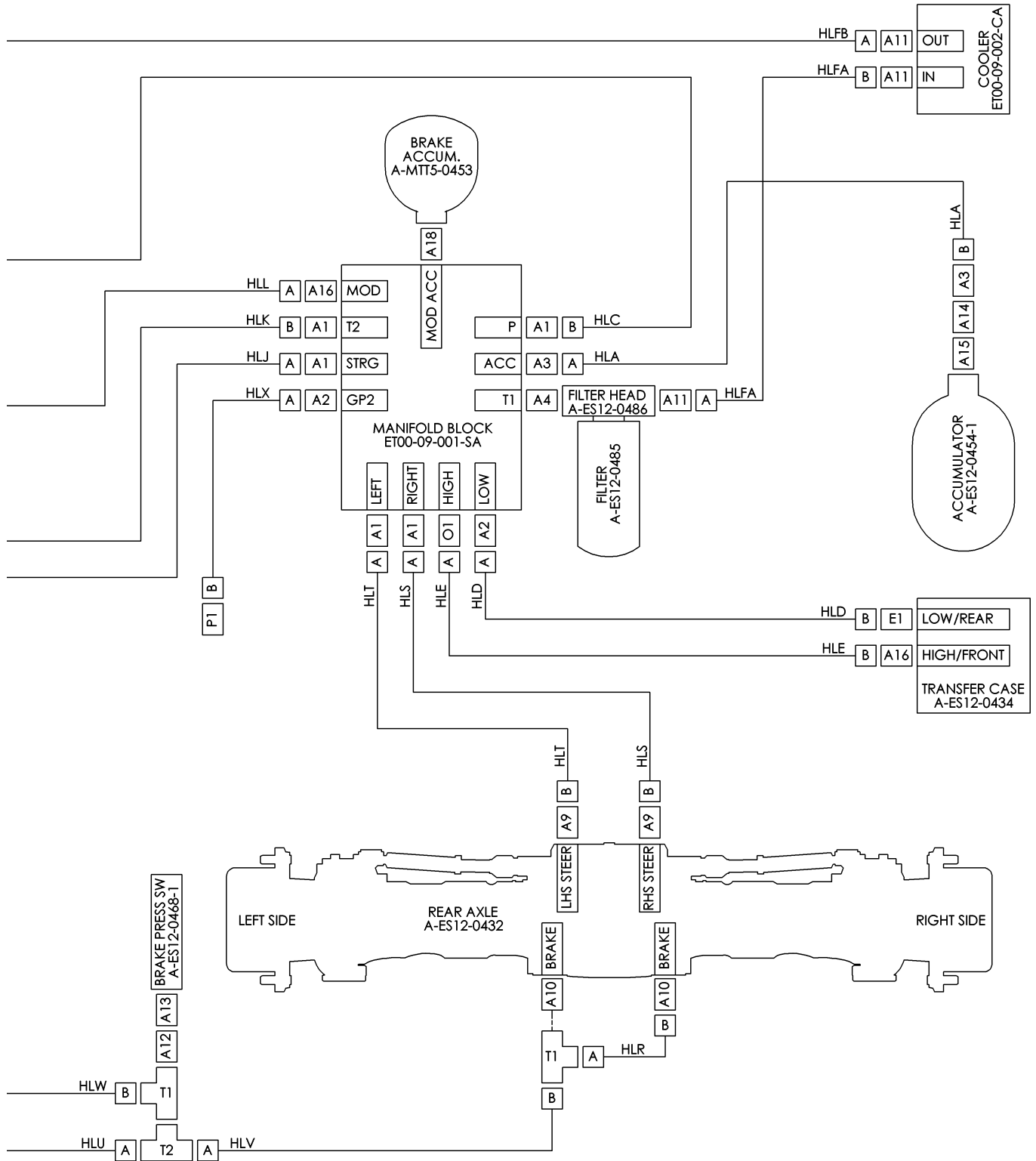

Hydraulic Hoses

Item	Part Number End A - Length - End B	Hose	Description
HLA	08U-608-13.5-08U-688	H14508	ACCUMULATOR
HLB	12GMV, 32	12GMV	3/4" SUCTION HOSE X 32" LONG
HLC	06U-668-22-06U-666	H14506	PUMP PRESSURE
HLD	04U-604-28-04U-604	H42504	SHIFT - LOW
HLE	04U-684-15.5-04U-684	H42504	SHIFT - HIGH
HLFA	12U-672-13.5-12U-672	H14512	COOLER INLET
HLFB	12U-672-31.5-12U-692	H14512	COOLER OUTLET
HLG	06U-666-31-06U-648	H14506	FRONT STEER - R
HLH	06U-666-21.5-06U-648	H14506	FRONT STEER - L
HLJ	06U-606-16.5-06U-666	H14506	STEER PRESSURE
HLK	06U-646-13.5-06U-606	H14506	STEER RETURN
HLL	04U-684-18-04U-606	H42504	BRAKE PRESSURE FEED
HLM	06U-606-46-06U-686	H14506	BRAKE RETURN
HLP	04U-664-15-04U-684	H42504	FRONT BRAKE JUMPER
HLR	04U-664-15-04U-684	H42504	REAR BRAKE JUMPER
HLS	06U-686-86-06U-608	H14506	REAR STEER - R
HLT	06U-686-72-06U-608	H14506	REAR STEER - L
HLU	04U-664-17.5-04U-684	H42504	FRONT BRAKE
HLV	04U-604-68-04U-684	H42504	REAR BRAKE
HLW	04U-664-19-04U-664	H42504	BRAKE PRESSURE FROM PUMP
HLX	06U-684-12-06U-606	H14506	SHIFT VALVE DAMPENER

Hydraulic Fittings

Item	Part Number	Qty.	Description
A1	C5315X6	7	ADAPTOR - 6 SAE ORB M - 6 JIC M
A2	C5315X4	2	ADAPTOR - 4 SAE ORB M - 4 JIC M
A3	C5315X8	2	ADAPTOR - 8 SAE ORB M - 8 JIC M
A4	C5314X12X12	1	ADAPTOR - 12 SAE ORB M - 12 SAE ORB M
A5	C5315X12X16	1	ADAPTOR - 16 SAE ORB M - 12 JIC M
A6	C5315X12X10	2	ADAPTOR - 10 SAE ORB M - 12 JIC M
A7	C5315X6X8	4	ADAPTOR - 8 SAE ORB M - 6 JIC M
A8	30682-12-12	2	ADAPTOR - 12 JIC F - .75 HOSE BARB
A9	MC5315X8X18	4	ADAPTOR - M18X1.5 DIN M - 8 JIC M
A10	MC5315X4X10	4	ADAPTOR - M10x1.0 DIN M - 4 JIC M
A11	C5315X12	3	ADAPTOR - 12 SAE ORB M - 12 JIC M
A12	C5216X4X4	1	ADAPTOR - 4 SAE ORB M - 4 JIC F
A13	4 G5HG5-S	1	ADAPTOR - 4 SAE ORB F - 4 SAE ORB F
A14	20-8 F5OG5-S	1	ADAPTOR - 20 SAE ORB M - 8 SAE ORB F
A15	7033X24X20	1	ADAPTOR - 24 SAE ORB M - 20 SAE ORB F
A16	C5315X4X6	2	ADAPTOR - 6 SAE ORB M - 4 JIC M
A17	C5315X8X10	1	ADAPTOR - 10 SAE ORB M - 8 JIC M
A18	C5314X8X8	1	ADAPTOR - 8 SAE ORB M - 8 SAE ORB M
A19	C5205X6X8	1	ADAPTOR - 6 JIC M - 8 NPT M
E1	C5515X4X6	2	ELBOW 90° - 6 SAE ORB M - 4 JIC M
O1	6400-04-04-0-R031	1	ORIFICE .031" - 4 SAE ORB M - 4 JIC M
T1	C5706X4	3	RUN TEE - 4 JIC
T2	4 WJJTX-S	1	BULKHEAD TEE - 4 JIC M
P1	C5229X6	1	PLUG - 6 JIC M

This page intentionally left blank.

Brake Pedal Installation

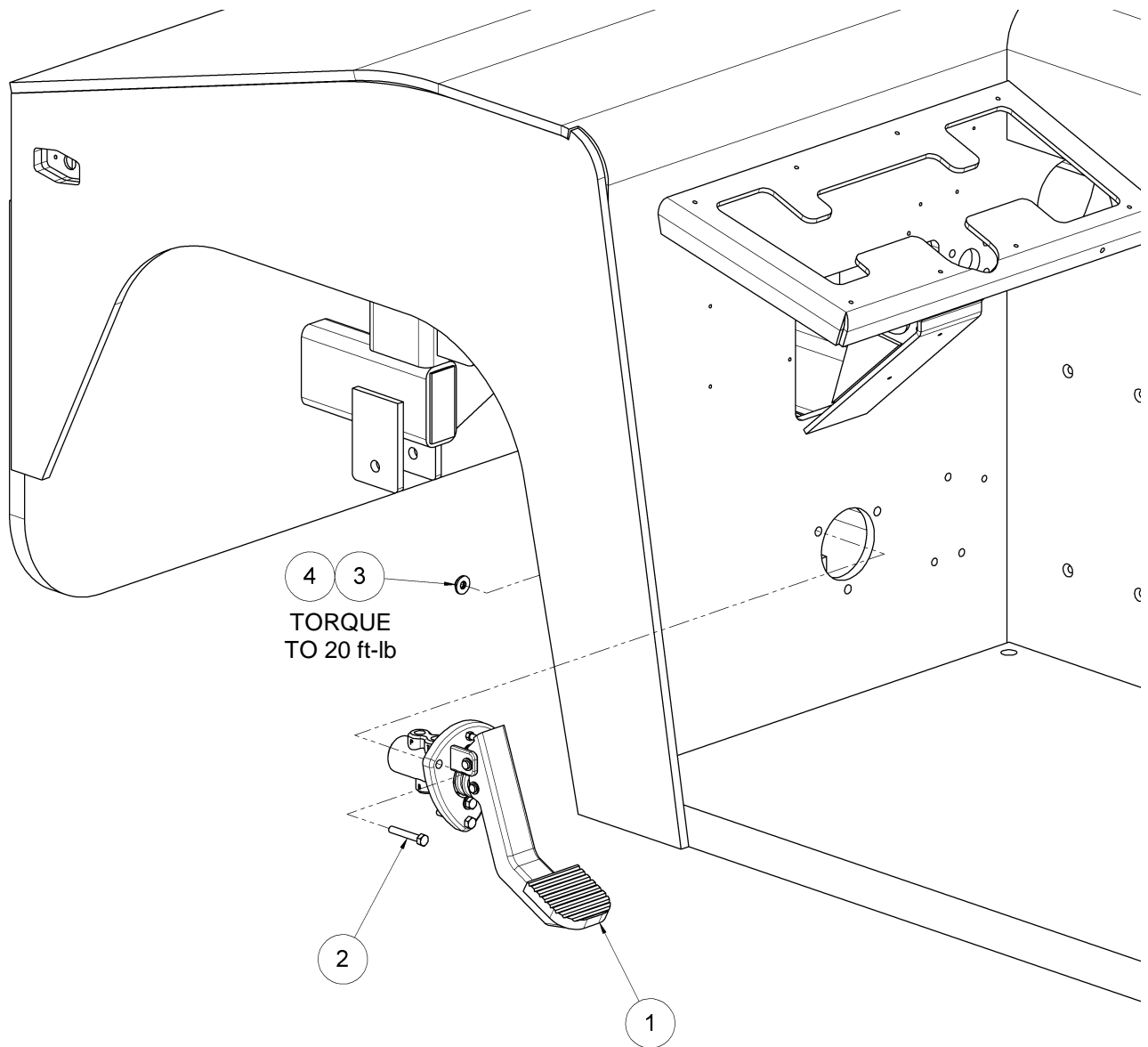

Item	Part Number	Qty.	Description
1	NPN	1	BRAKE VALVE AND PEDAL ASSEMBLY (SEE SECTION 6)
2	NPN	3	HCS, 5/16-18 UNC X 1.5, GR 8, ZN PLATED
3	NPN	3	FLAT WASHER, 5/16
4	NPN	3	LOCK NUT, 5/16-18 UNC

Steering And Brake Hoses

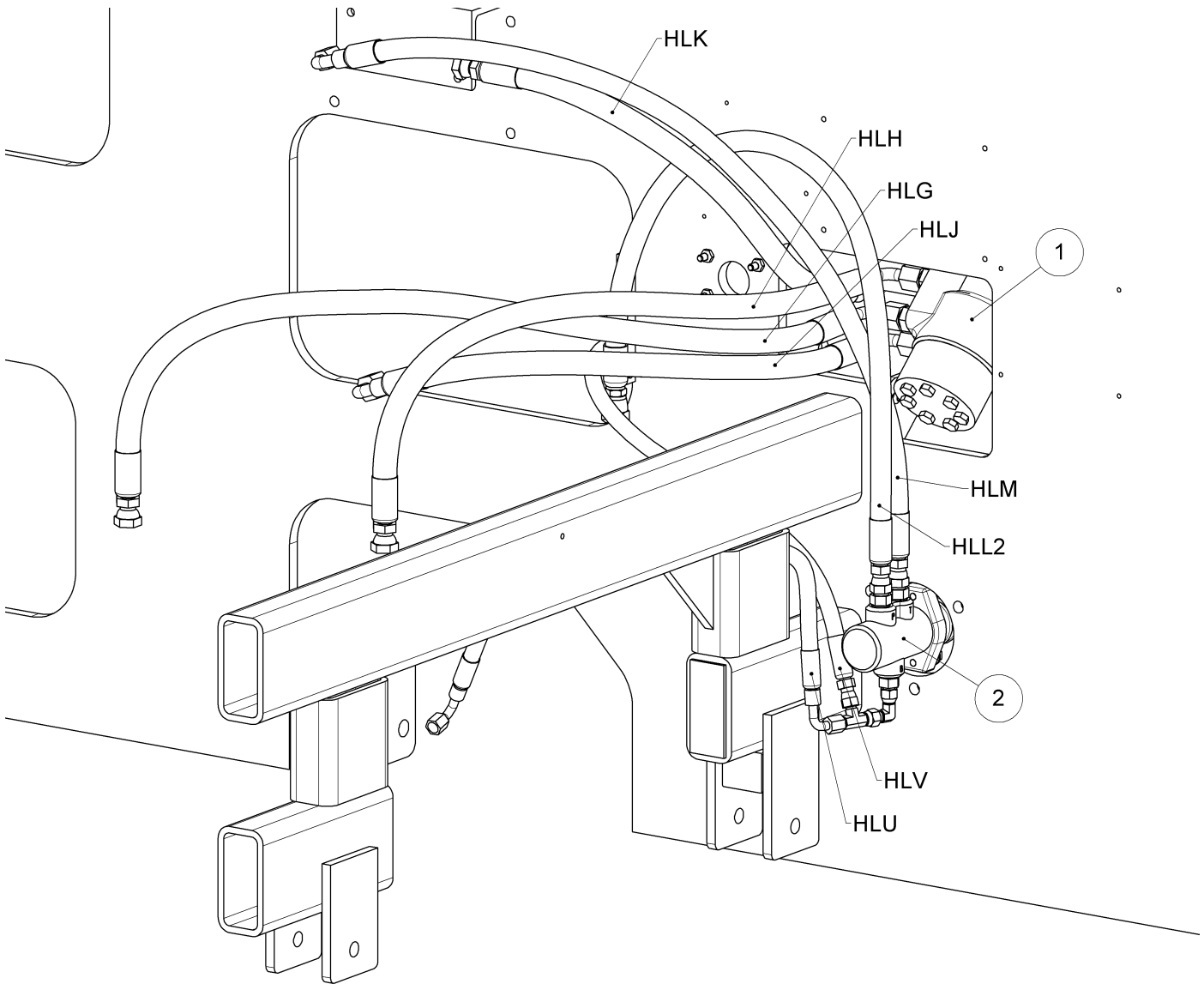

Item	Part Number	Qty.	Description
1	NPN	1	STEER ORBITAL (SEE SECTION 8 FOR INSTALLATION)
2	NPN	1	BRAKE MODULATING VALVE (SEE BRAKE PEDAL INSTALLATION)

Steering And Brake Hoses

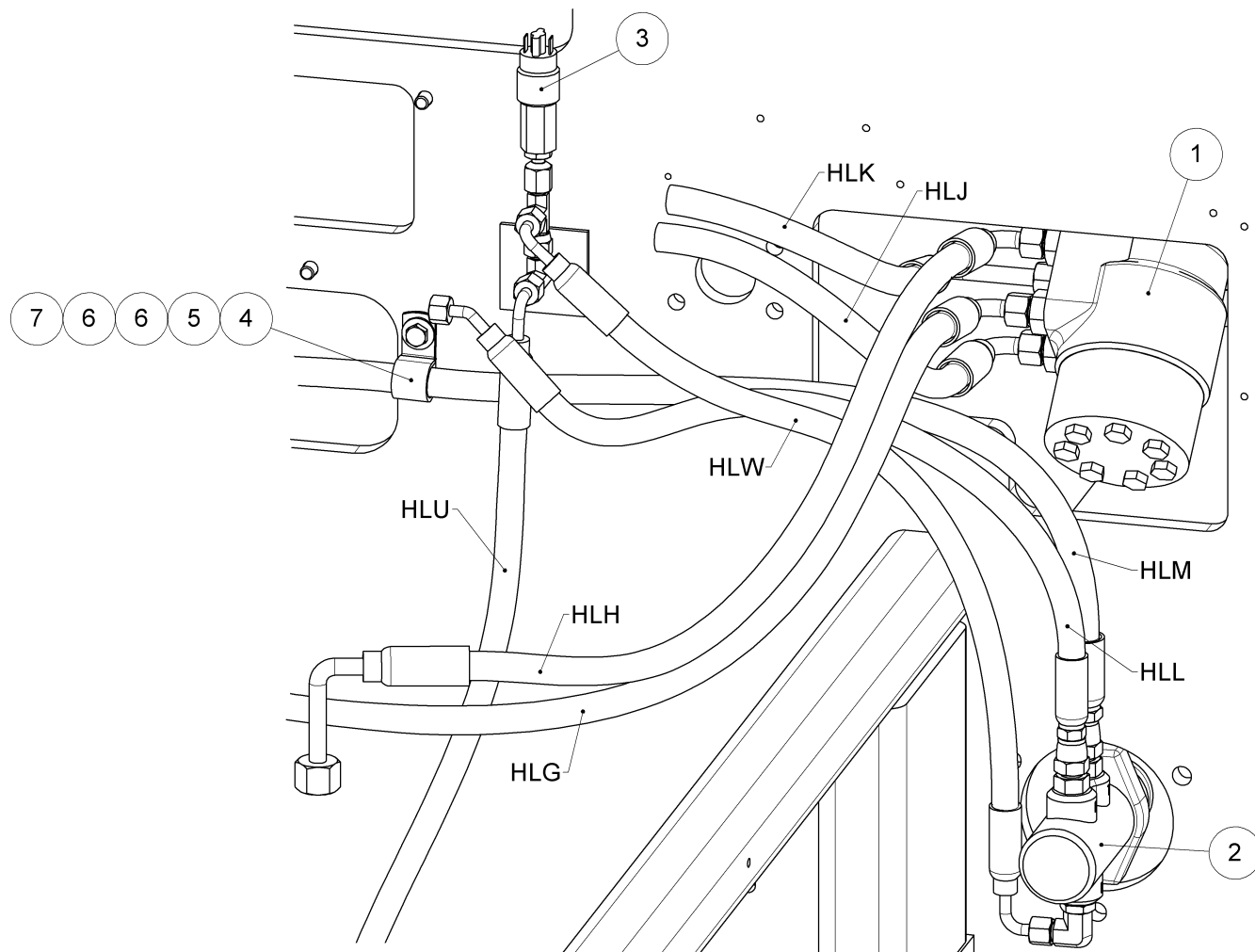

Item	Part Number	Qty.	Description
1	NPN	1	STEER ORBITAL (SEE SECTION 8 FOR INSTALLATION)
2	NPN	1	BRAKE VALVE (SEE BRAKE PEDAL INSTALLATION)
3	A-ES12-0468-1	1	BRAKE PRESSURE SWITCH
4	NPN	1	CUSHIONED LOOP CLAMP
5	NPN	1	HCS, 1/4-20 UNC X 1
6	NPN	2	FLAT WASHER, 1/4
7	NPN	1	LOCK NUT, 1/4-20 UNC

Hydraulic Cooler Installation and Hoses

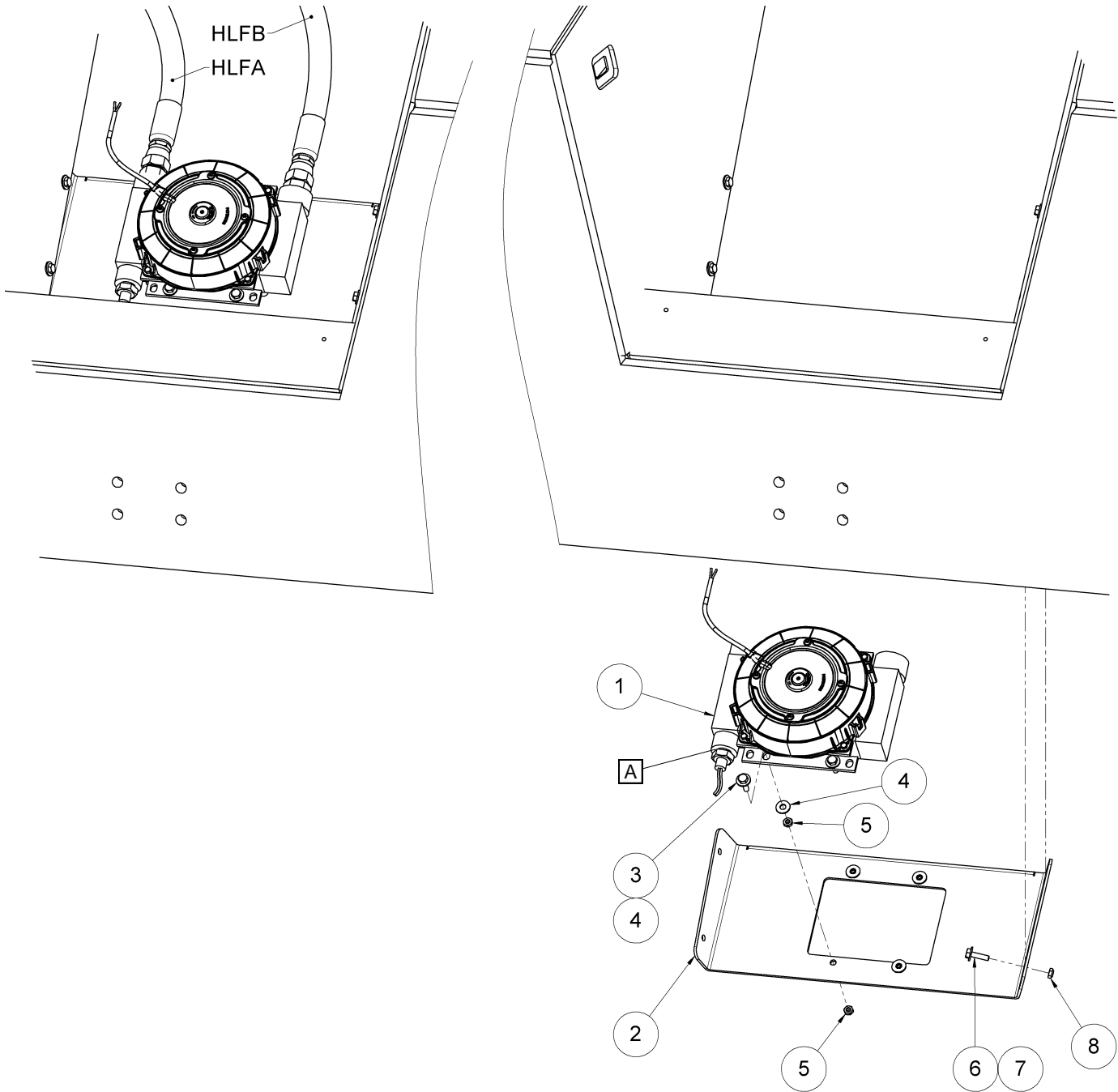

A Verify temp switch is installed inline with cooler inlet.

Item	Part Number	Qty.	Description
1	NPN	1	COOLER ASSEMBLY (SEE SECTION 6)
2	A-ES12-0542	1	HYDRAULIC COOLER BRACKET
3	NPN	4	HCS, 1/4-20 UNC X 1
4	NPN	8	FLAT WASHER, 1/4
5	NPN	8	LOCK NUT, 1/4-20 UNC
6	NPN	4	HCS, 5/16-18 UNC X 1.25
7	NPN	8	FLAT WASHER, 5/16
8	NPN	4	LOCK NUT, 5/16-18 UNC

Hydraulic Cooler Installation and Hoses

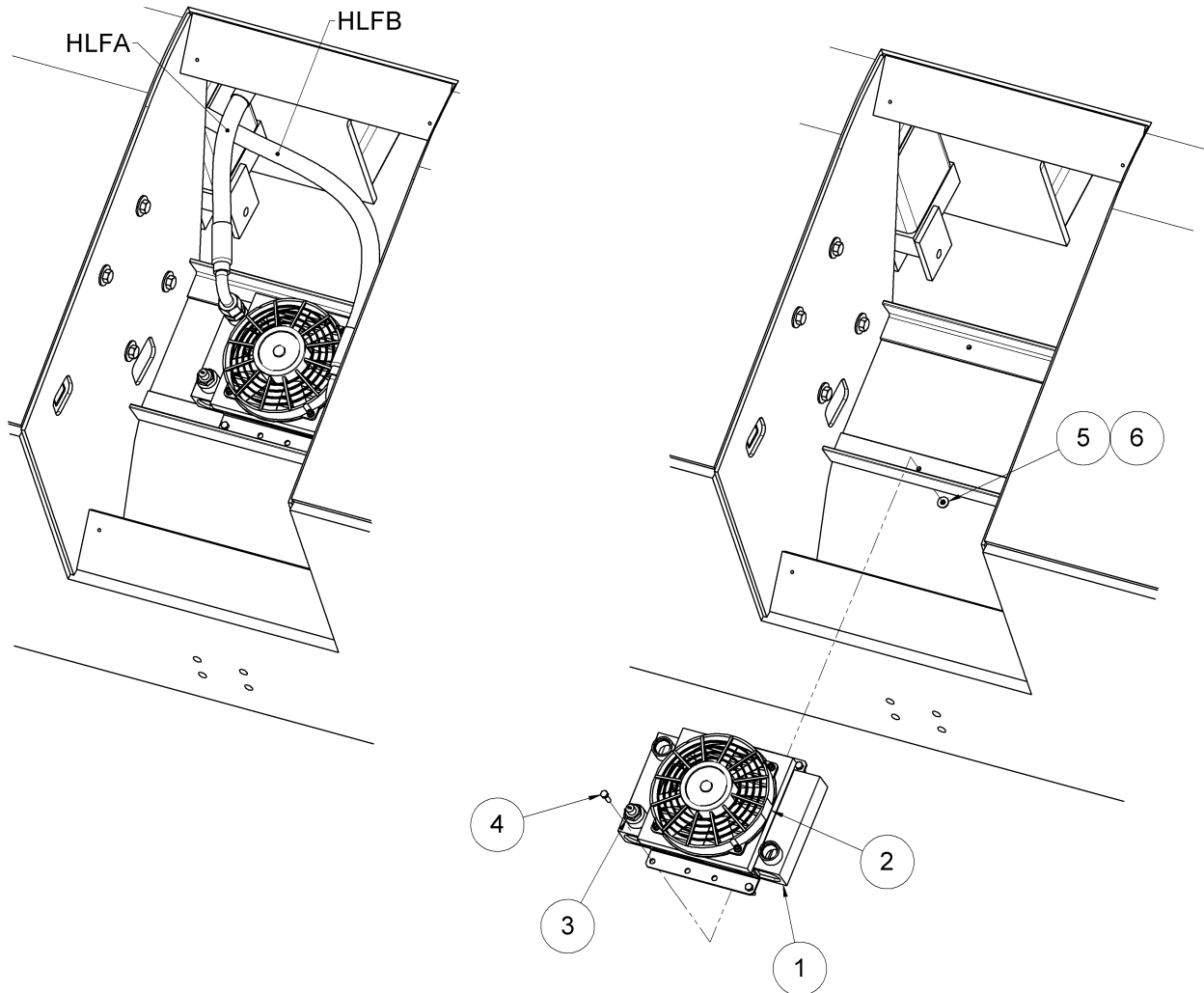

Item	Part Number	Qty.	Description
1	ET00-09-002-CA	1	HYDRAULIC COOLER ASSEMBLY
2	ET00-59-011-CA	-	HYD COOLER FAN (INCLUDED IN ITEM 1)
3	ET00-59-010-CA	-	HYD COOLER TEMP SWITCH (INCLUDED IN ITEM 1)
4	NPN	4	HCS, 1/4-20 UNC X 1
5	NPN	4	FLAT WASHER, 1/4
6	NPN	4	LOCK NUT, 1/4-20 UNC
7	DT04-4P	1	ELECTRICAL CONNECTOR (INSTALLED TO ITEM 1)
8	W4P	1	CONNECTOR LOCK (INSTALLED TO ITEM 1)
9	0460-215-16141	4	CONNECTOR PINS (INSTALLED TO ITEM 1)

Item 1 to be wired as shown below.

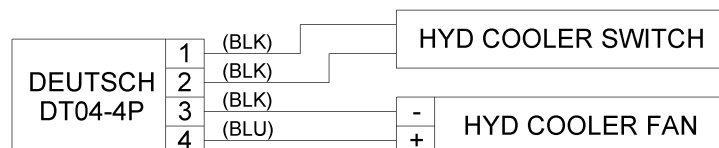

Tank Installation

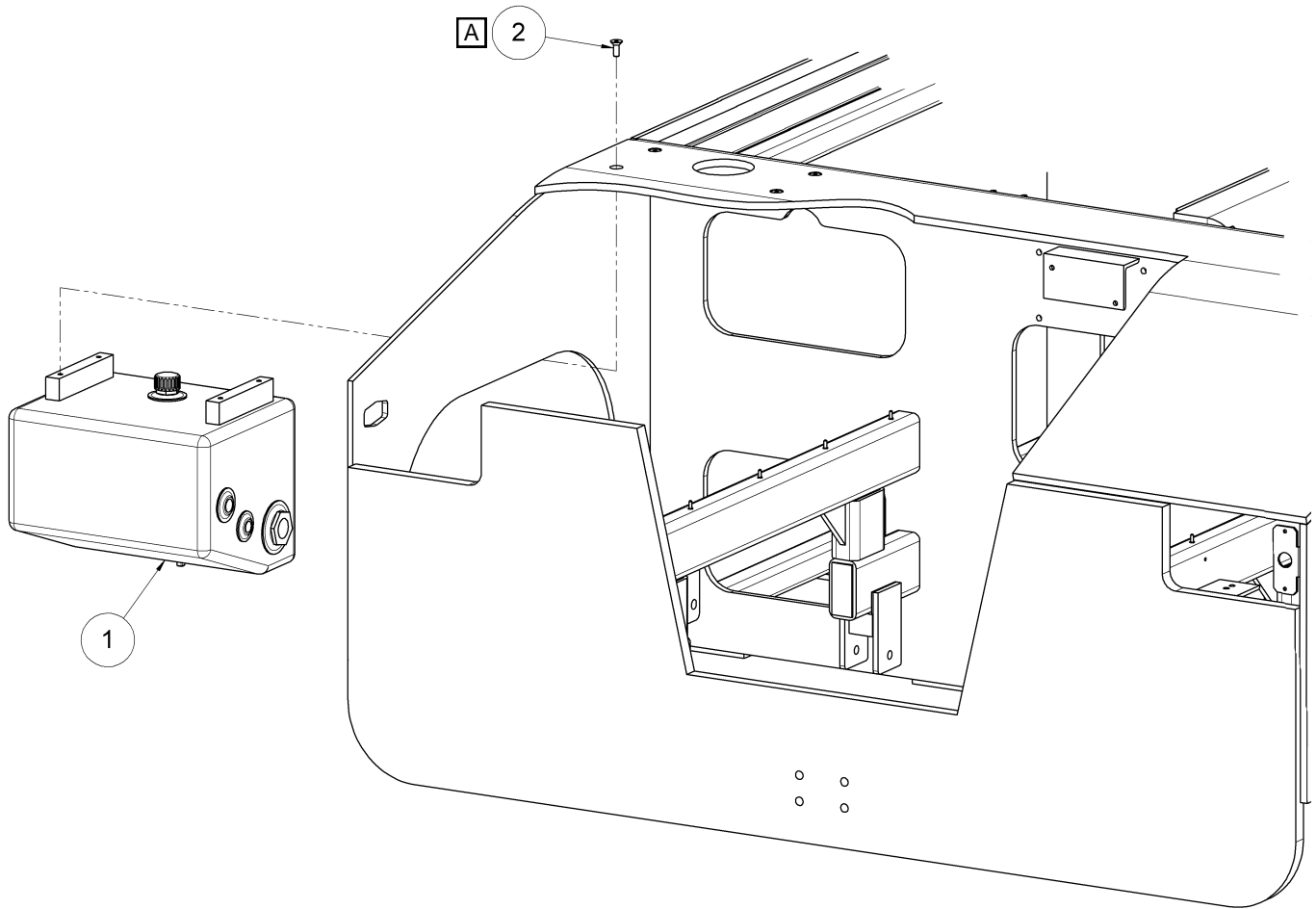

A Use Permatex® Anti-Seize Lubricant or equivalent.

Item	Part Number	Qty.	Description
1	NPN	1	HYDRAULIC TANK ASSEMBLY (SEE SECTION 6)
2	NPN	4	FHCS, 3/8-16 UNC X 1, SS

Pump Installation

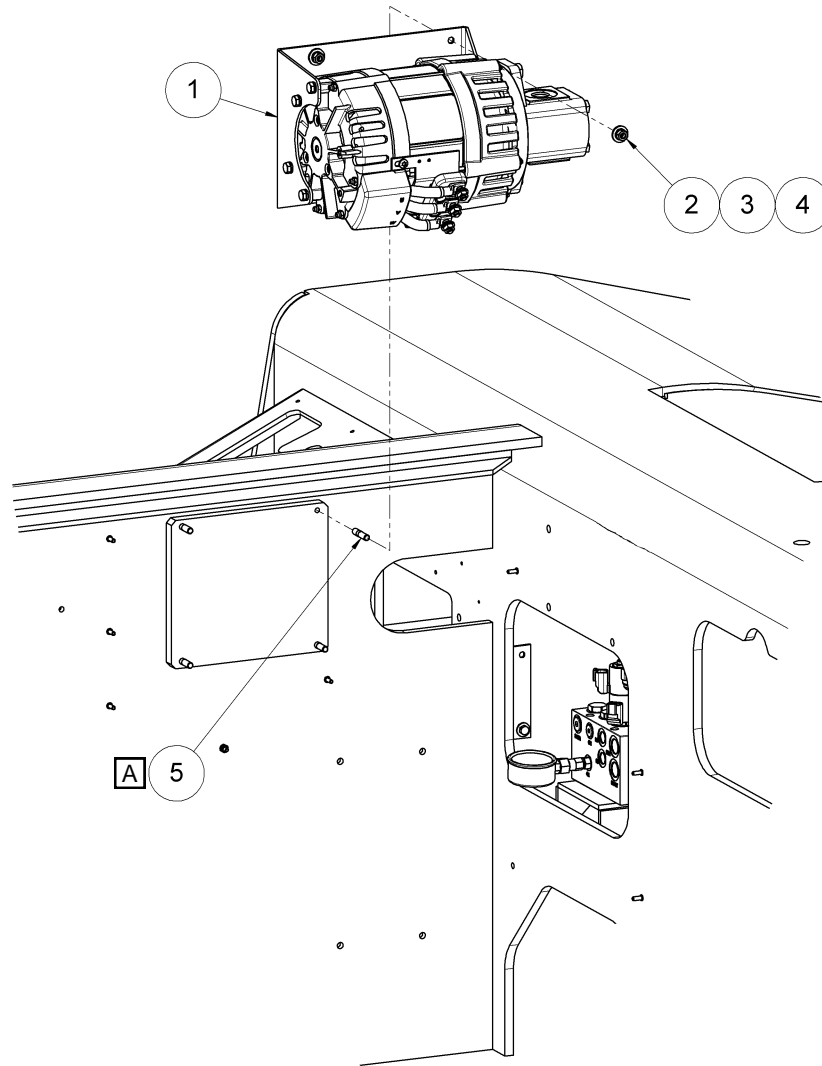

A Install specified components using Loctite® Threadlocker Blue 242® thread retaining compound or comparable

Item	Part Number	Qty.	Description
1	NPN	1	HYDRAULIC PUMP ASSEMBLY (SEE SECTION 6)
2	NPN	4	NUT, 5/16-18 UNC
3	NPN	4	LOCK WASHER, 5/16
4	NPN	4	FLAT WASHER, 5/16
5	NPN	4	STUD, 5/16-18 UNC X 7/8 X 5/16-18 UNC X 7/16 X 1.5 OAL

Tank and Pump Hoses

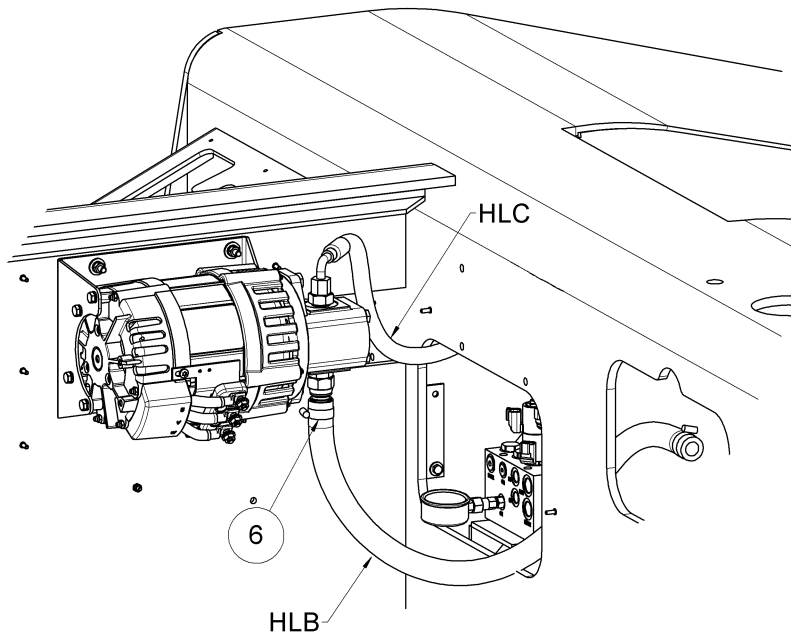
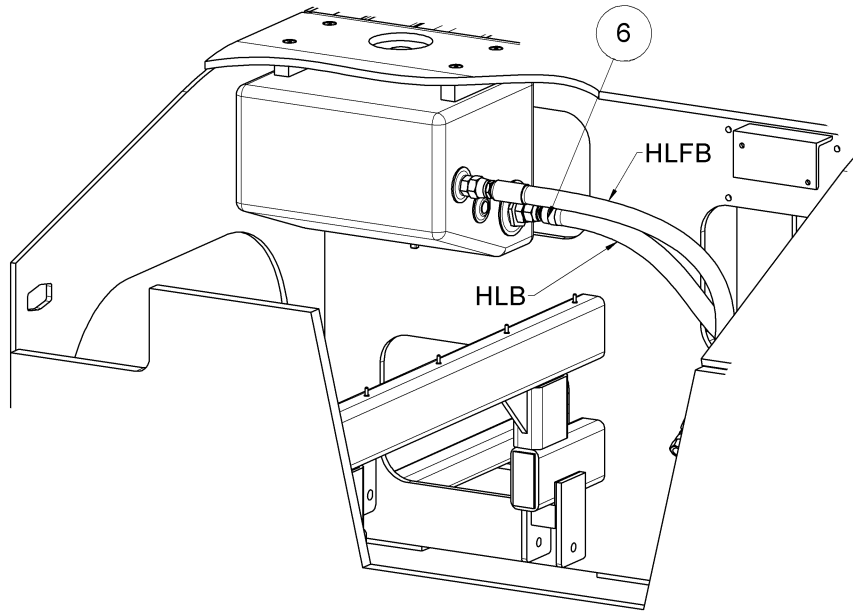

Item	Part Number	Qty.	Description
6	NPN	2	SAE HOSE CLAMP, #12

Tank and Pump Hoses

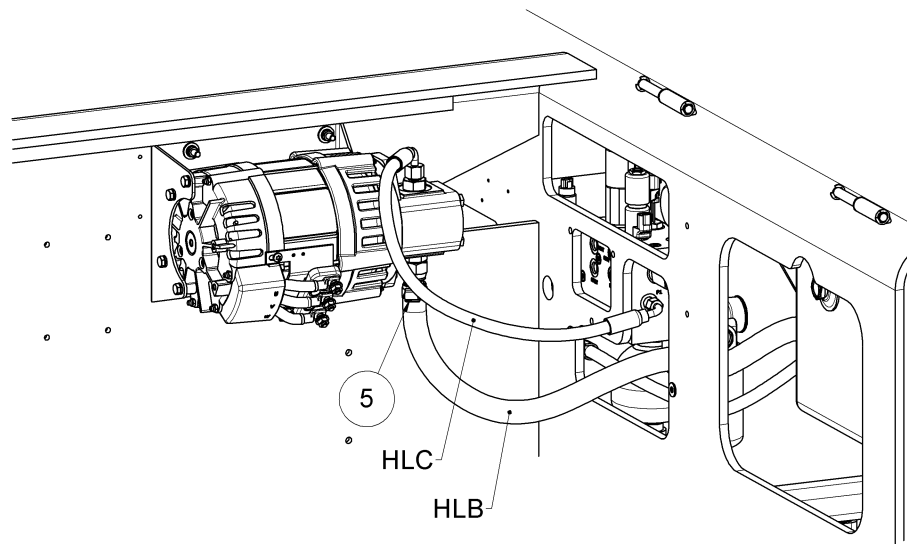
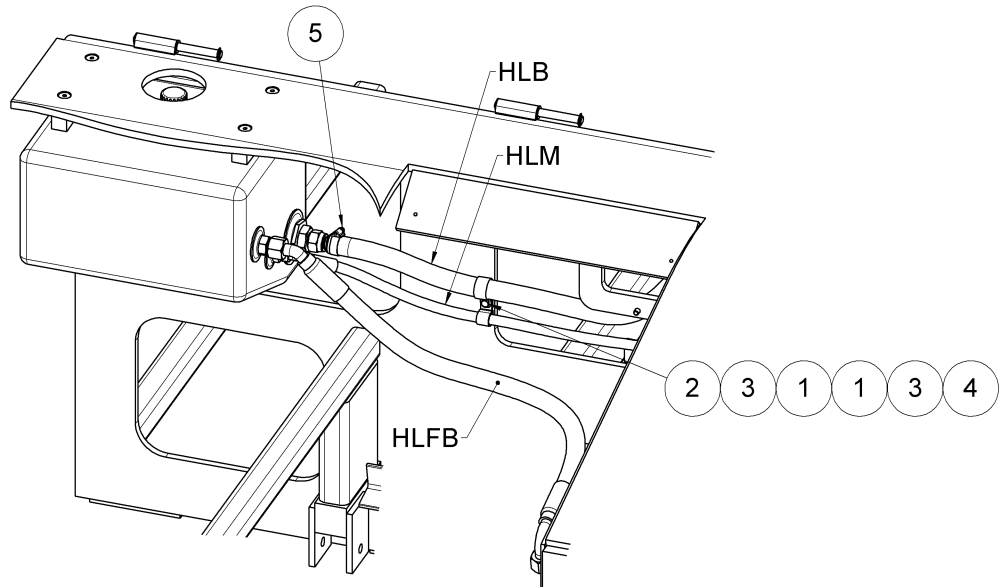

Item	Part Number	Qty.	Description
1	NPN	2	CUSHIONED LOOP CLAMP
2	NPN	1	HCS, 1/4-20 UNC X 1.25
3	NPN	2	FLAT WASHER, 1/4
4	NPN	1	LOCK NUT, 1/4-20 UNC
5	NPN	2	SAE HOSE CLAMPS, #12

Main Accumulator Installation and Hoses

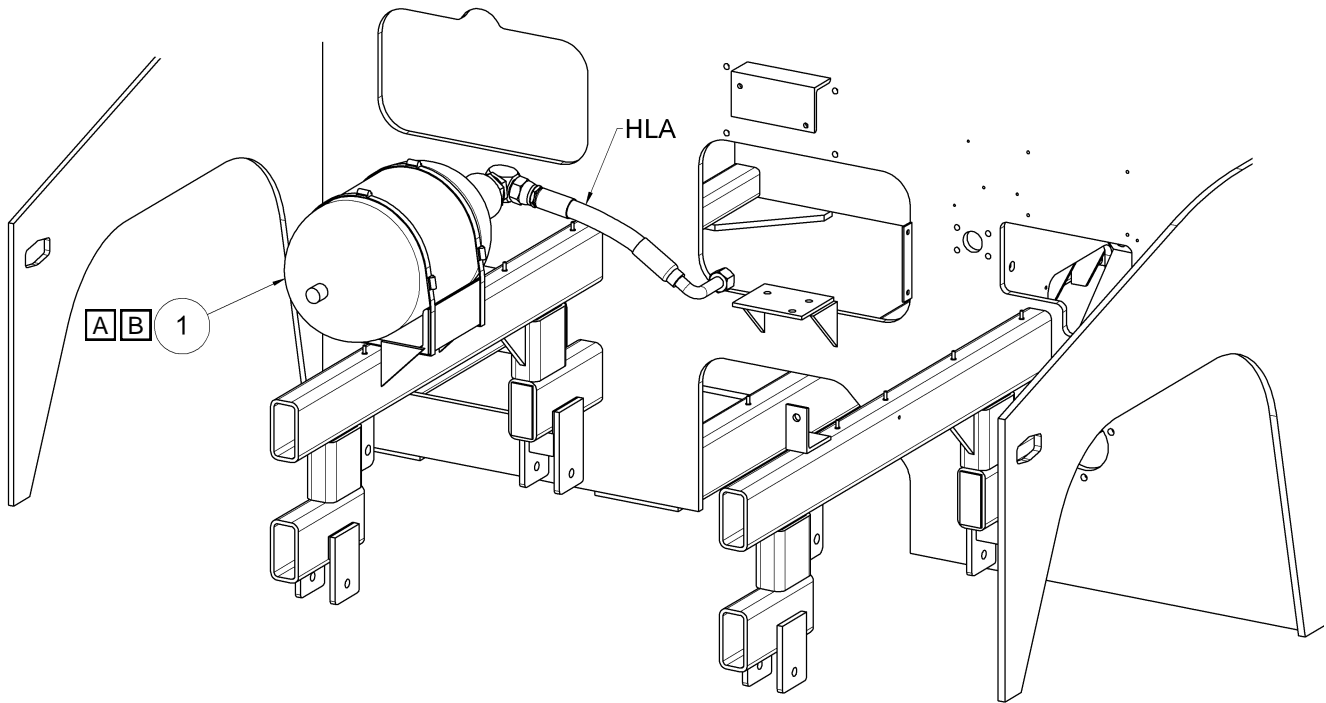

- A** Pre-charge accumulator with dry nitrogen gas to 1600 psi \pm 200 psi.
- B** Secure to bracket using SAE hose clamps as needed.

Item	Part Number	Qty.	Description
1	A-ES12-0454-1	1	ACCUMULATOR, 2.5 GAL
-	ET00-59-009-CA	-	ACCUMULATOR REPAIR KIT
-	NVSP-59-001-CA	-	ACCUMULATOR RECHARGE KIT

Main Accumulator Installation and Hoses

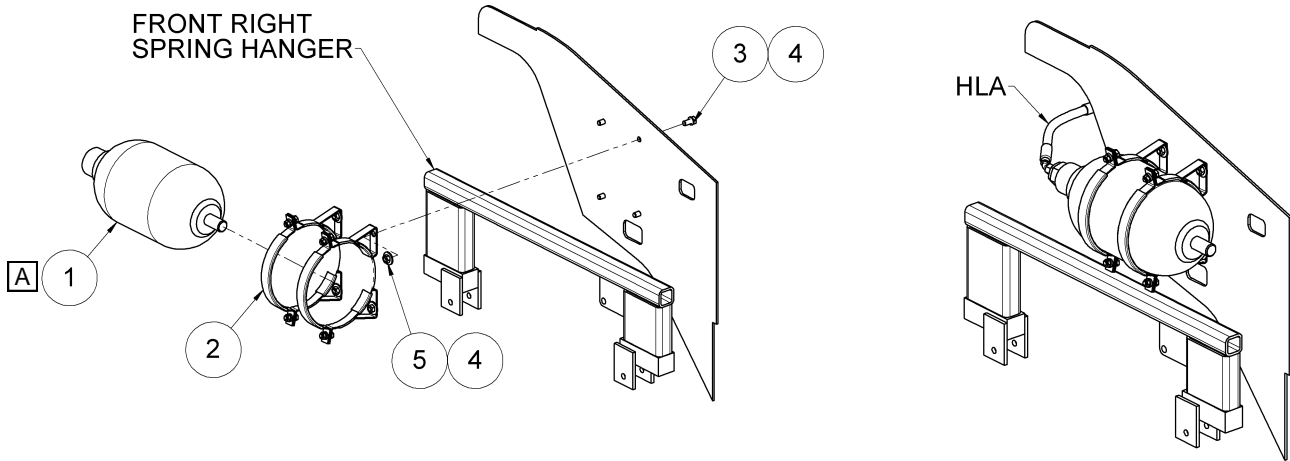

A Pre-charge accumulator with dry nitrogen gas to 1600 psi ± 200 psi.

Item	Part Number	Qty.	Description
1	A-ES12-0454-1	1	ACCUMULATOR, 2.5 GAL
-	ET00-59-009-CA	-	ACCUMULATOR REPAIR KIT, 2.5 GAL - BLADDER, VALVE, SEALS
-	NVSP-59-001-CA	-	ACCUMULATOR CHARGE KIT
2	A-EXL16-0454	2	ACCUMULATOR MOUNTING BRACKET
3	NPN	4	HCS, 1/2-13 UNC X 1.25
4	NPN	8	FLAT WASHER, 1/2
5	NPN	4	LOCK NUT, 1/2-13 UNC

Brake Accumulator Installation and Hoses

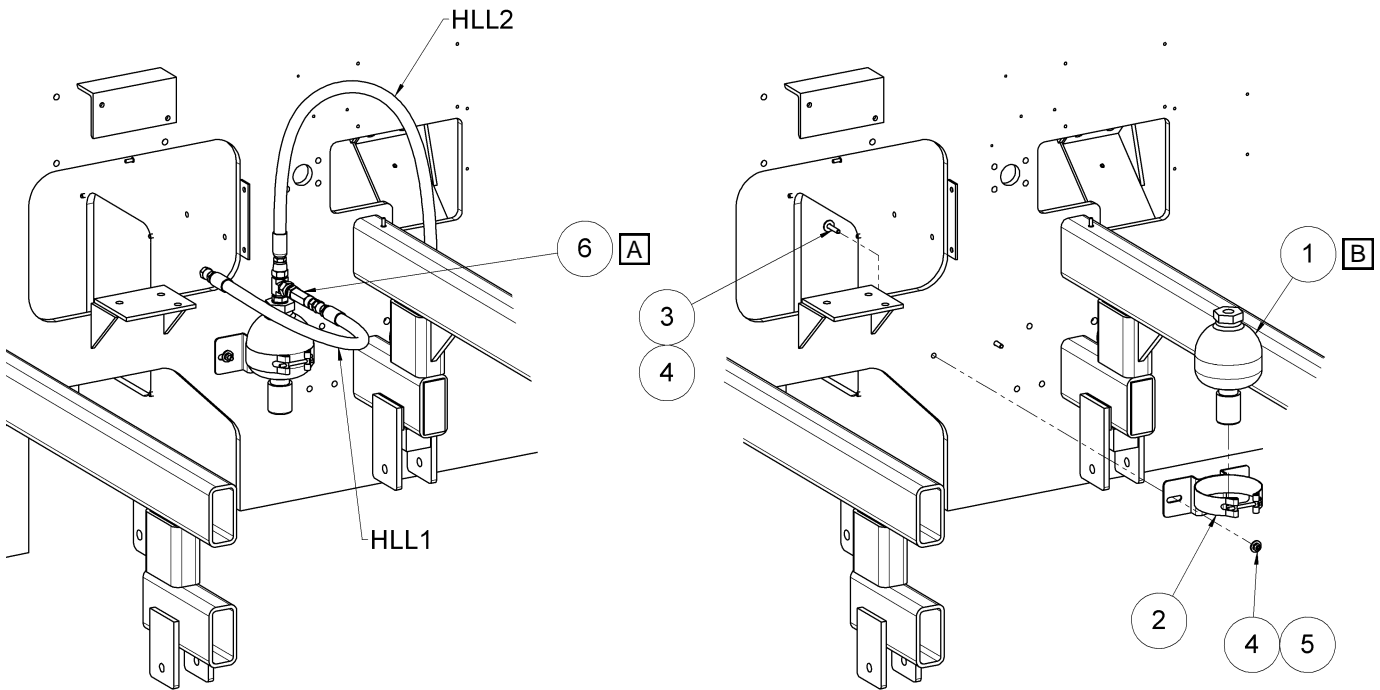

- A** Arrow on check valve to point toward Accumulator.
- B** Pre-charge accumulator with dry nitrogen gas to 750 psi ± 100 psi.

Item	Part Number	Qty.	Description
1	A-MTT5-0453	1	ACCUMULATOR, .5L
2	A-MTT5-0454	1	ACCUMULATOR BRACKET
3	NPN	2	HCS, 1/4-20 UNC X 1.25
4	NPN	4	FLAT WASHER, 1/4
5	NPN	2	LOCK NUT, 1/4-20 UNC
6	A-ES12-0553	1	CHECK VALVE

Return Filter Assembly Installation and Hoses

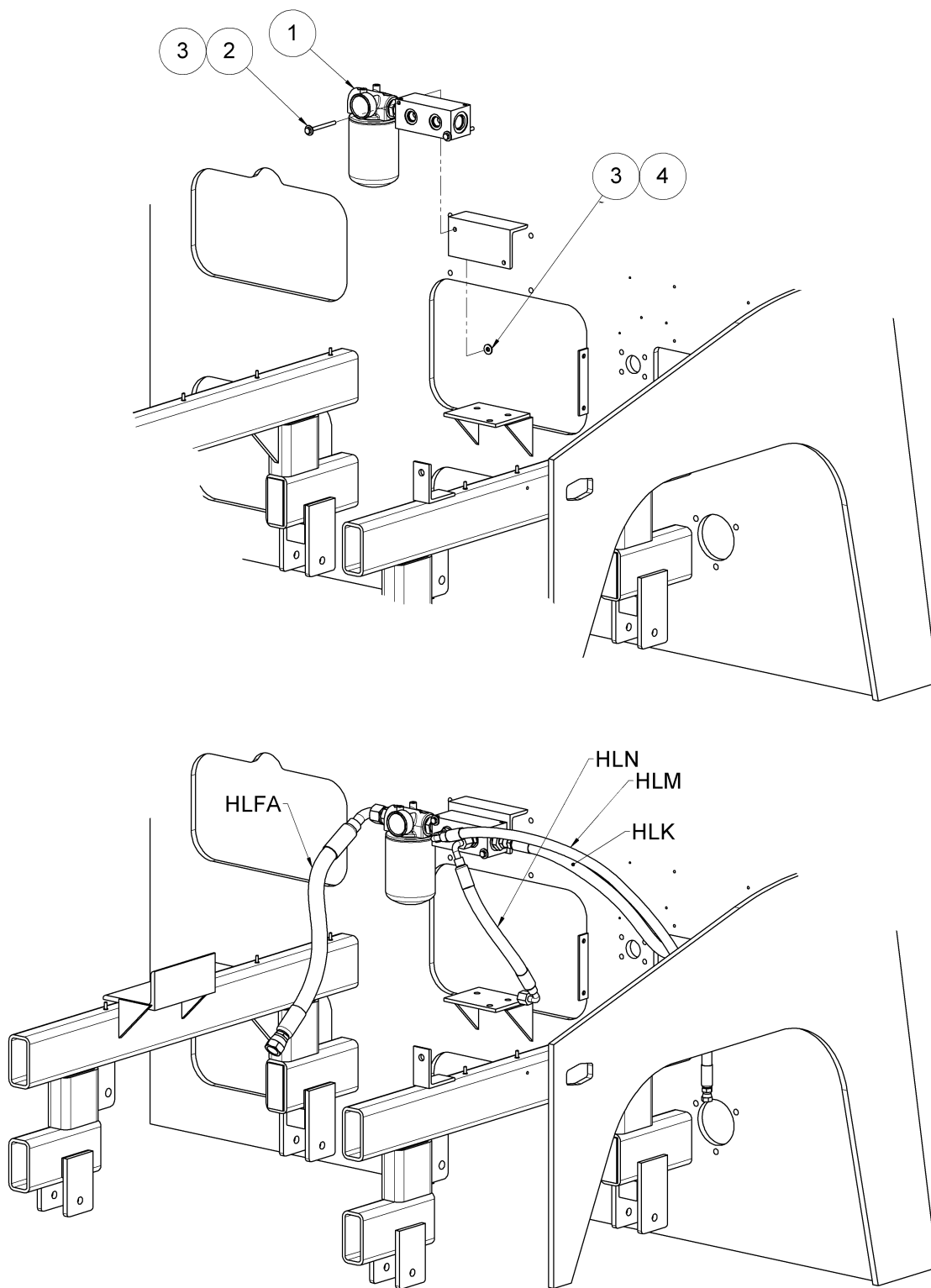

Item	Part Number	Qty.	Description
1	NPN	1	RETURN FILTER ASSEMBLY (SEE SECTION 6)
2	NPN	2	HCS, 1/4-20 UNC X 3
3	NPN	4	FLAT WASHER, 1/4
4	NPN	2	LOCK NUT, 1/4-20 UNC

Manifold Installation and Hoses to Front

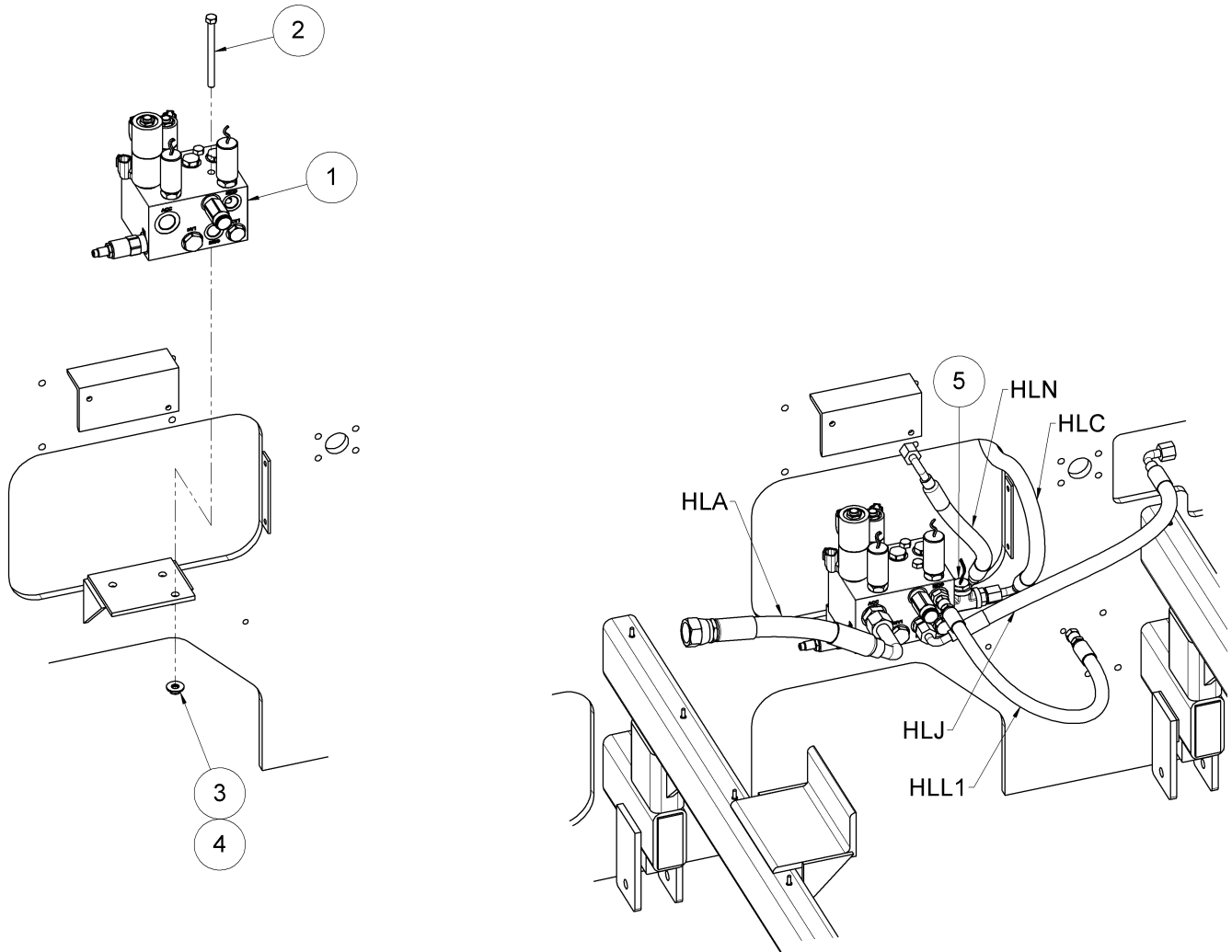

Item	Part Number	Qty.	Description
1	NPN	1	HYDRAULIC MANIFOLD ASSEMBLY (SEE SECTION 6)
2	NPN	3	HCS, 3/8-16 UNC X 4.5
3	NPN	3	FLAT WASHER, 3/8
4	NPN	3	LOCK NUT, 3/8-16 UNC
5	A-ES12-0484-2	1	TEMPERATURE SWITCH
N/A	DT04-2P	2	ELECTRICAL CONNECTOR (INSTALLED TO ITEM 5)
N/A	W2P	2	CONNECTOR LOCK (INSTALLED TO ITEM 5)
N/A	0460-215-16141	4	CONNECTOR PINS (INSTALLED TO ITEM 5)

Item 5 to be wired as shown below.

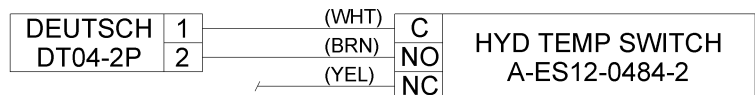

Manifold Hoses to Back

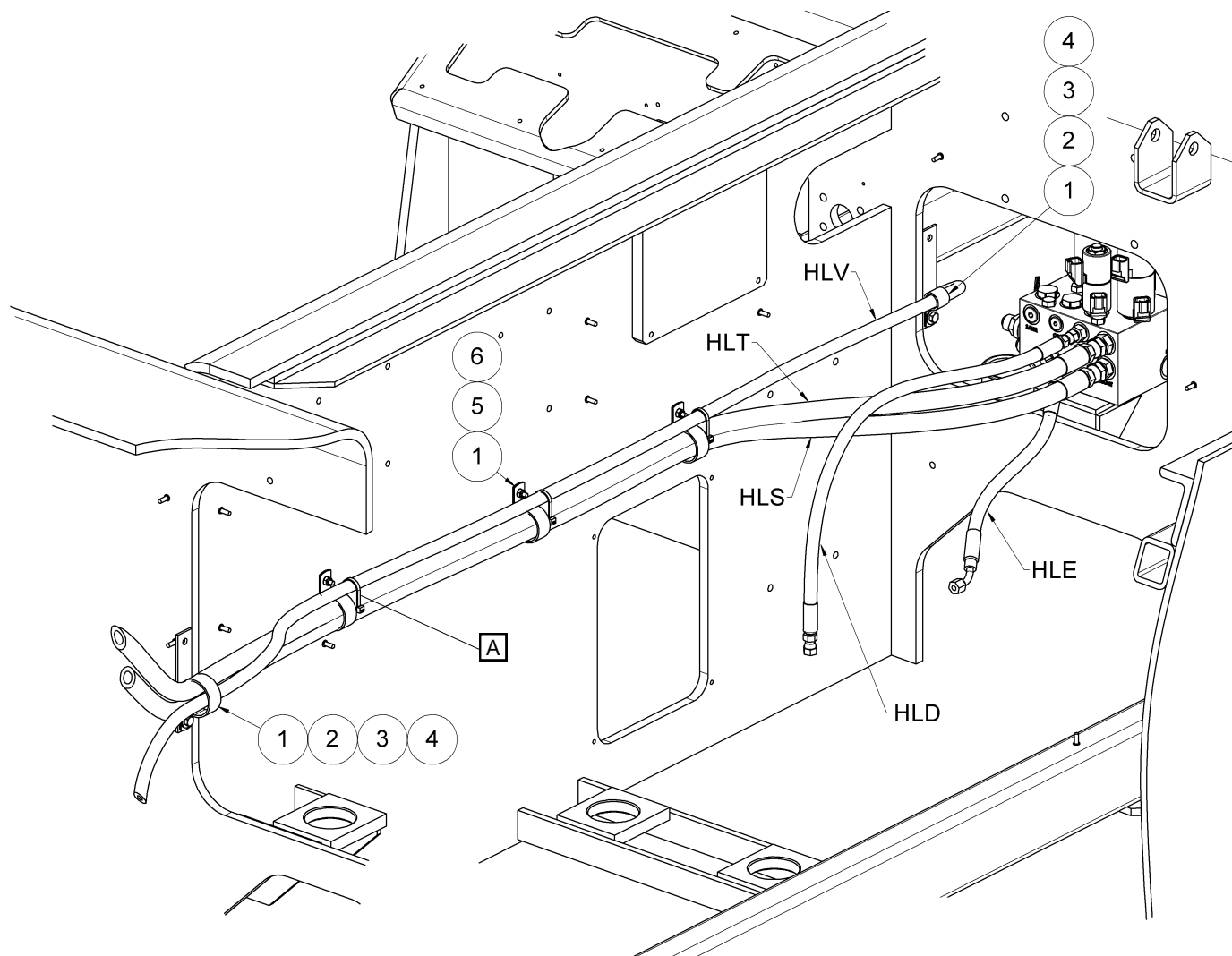

A Secure HLV to HLT using plastic zip ties, 3 places.

Item	Part Number	Qty.	Description
1	NPN	5	CUSHIONED LOOP CLAMP
2	NPN	2	HCS, 1/4-20 UNC X 1
3	NPN	2	FLAT WASHER, 1/4
4	NPN	2	LOCK NUT, 1/4-20 UNC
5	NPN	3	FLAT WASHER, #10
6	NPN	3	LOCK NUT, #10-32 UNF

Manifold Installation and Hoses to Front

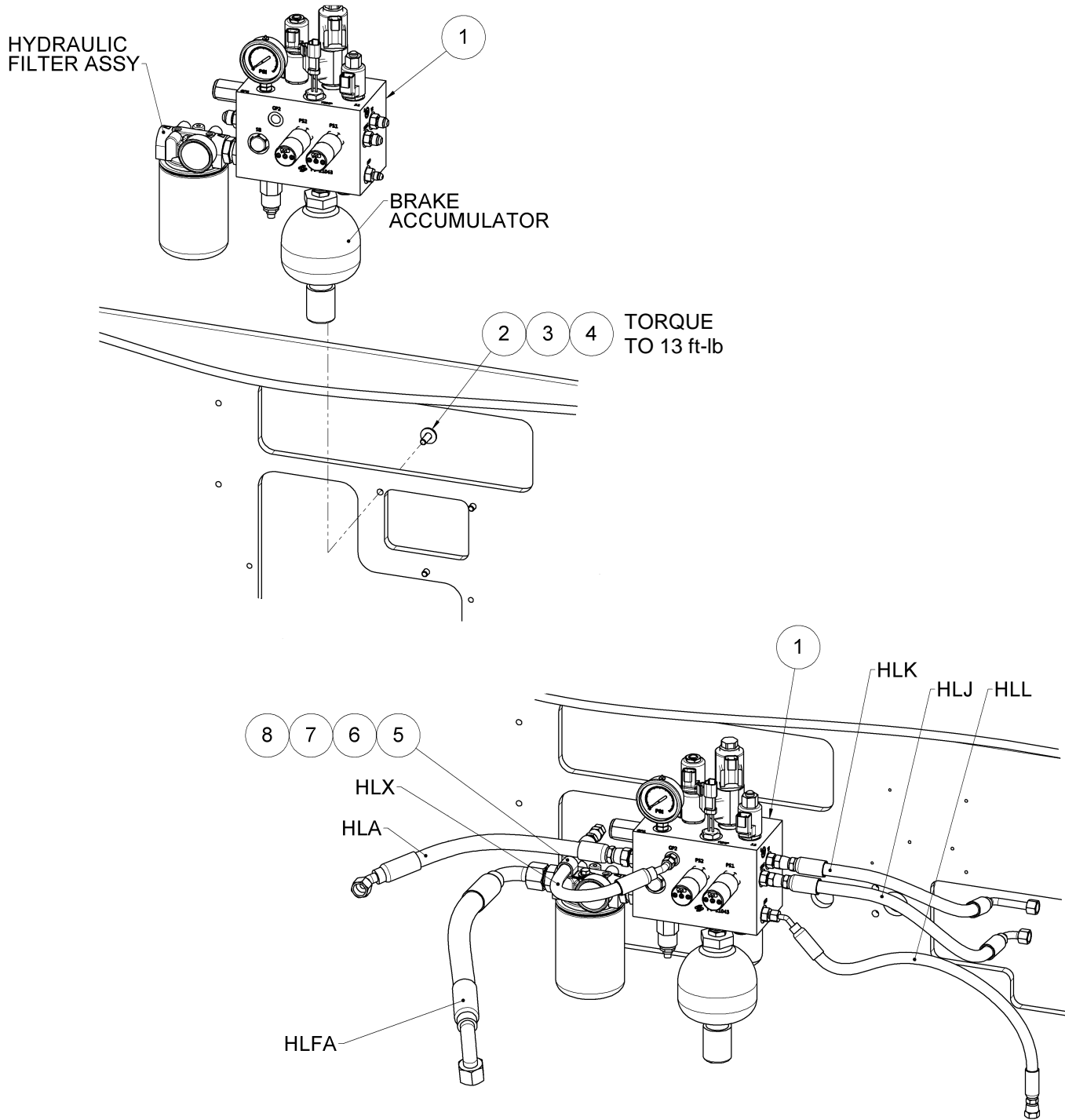

Item	Part Number	Qty.	Description
1	NPN	1	MANIFOLD ASSEMBLY (SEE SECTION 6 FOR PART NUMBERS)
2	NPN	3	HCS, 5/16-18 UNC X 1.25
3	NPN	3	LOCK WASHER, 5/16
4	NPN	3	FLAT WASHER, 5/16
5	NPN	1	CUSHION LOOP CLAMP, 3/4
6	NPN	1	HCS, 1/4-20 UNC X .5
7	NPN	1	LOCK WASHER, 1/4
8	NPN	1	FLAT WASHER, 1/4

Manifold Hoses to Back

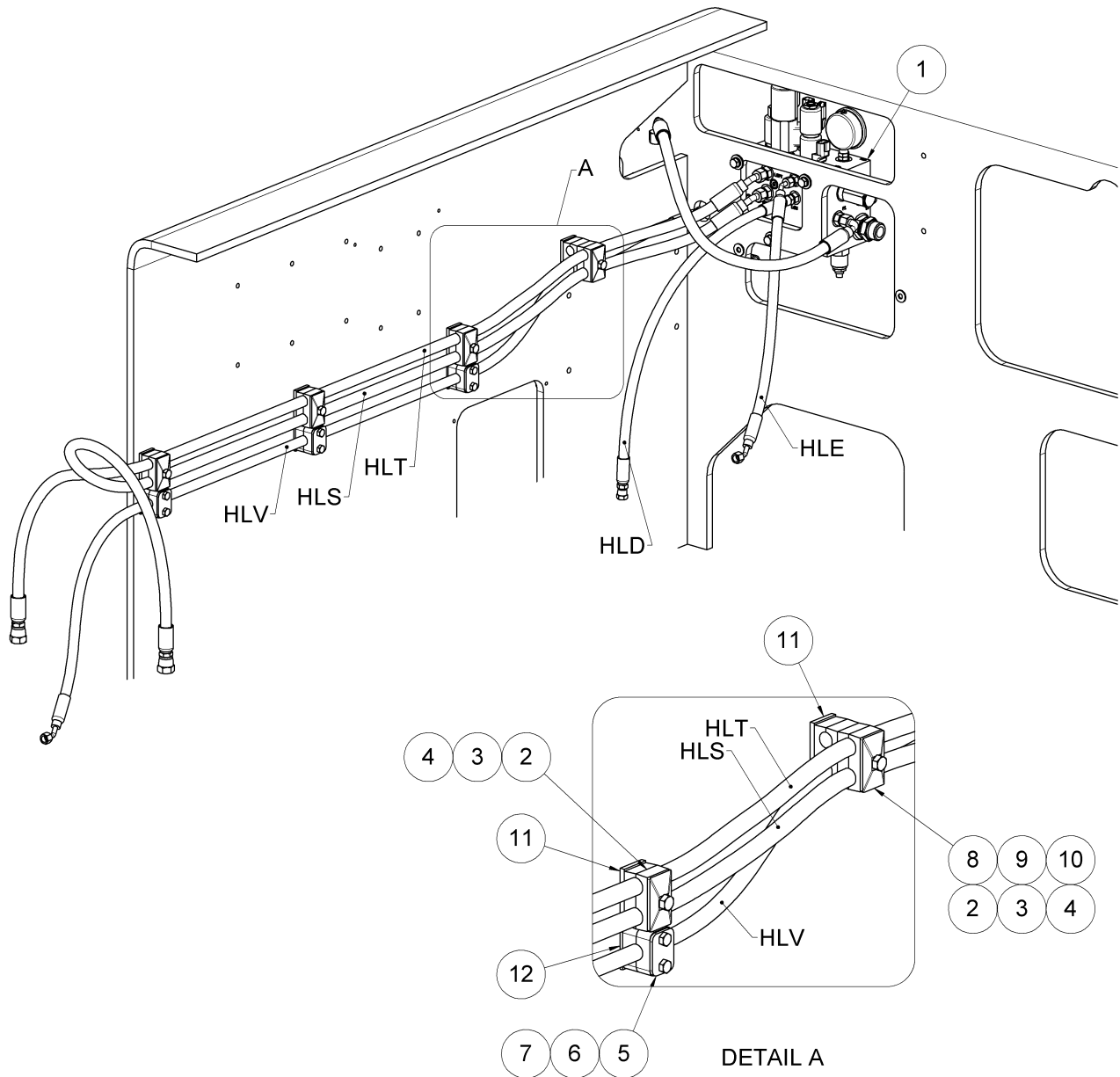

Item	Part Number	Qty.	Description
1	NPN	1	MANIFOLD ASSEMBLY (SEE SECTION 6 FOR PART NUMBERS)
2	NVSP-24-015-CG	4	SMOOTH HYDRAULIC CLAMP, DUAL 16MM (2 HALVES)
3	NVSP-24-017-CC	4	HYDRAULIC CLAMP COVER PLATE, TWIN SIZE 2
4	NPN	4	HCS, 5/16-18 UNC X 1.5
5	NVSP-24-015-CH	3	SMOOTH HYDRAULIC CLAMP, SINGLE 15MM (2 HALVES)
6	NVSP-24-017-CD	3	HYDRAULIC CLAMP COVER PLATE, SINGLE GROUP 2
7	NPN	6	HCS, 1/4-20 UNC X 1.375
8	NVSP-24-015-CF	1	SMOOTH HYDRAULIC CLAMP, DUAL 15MM (2 HALVES)
9	NVSP-24-016-CC	1	STACKING BOLT, GROUP 2D
10	NVSP-24-018-CB	1	HYDRAULIC TUBE CLAMP SAFETY PLATE, TWIN SIZE 2-5
11	NVSP-24-028-CA	4	HYDRAULIC CLAMP WELD PLATE, GROUP 2D
12	NVSP-24-028-CB	3	HYDRAULIC CLAMP WELD PLATE, GROUP 2

Axle Hoses

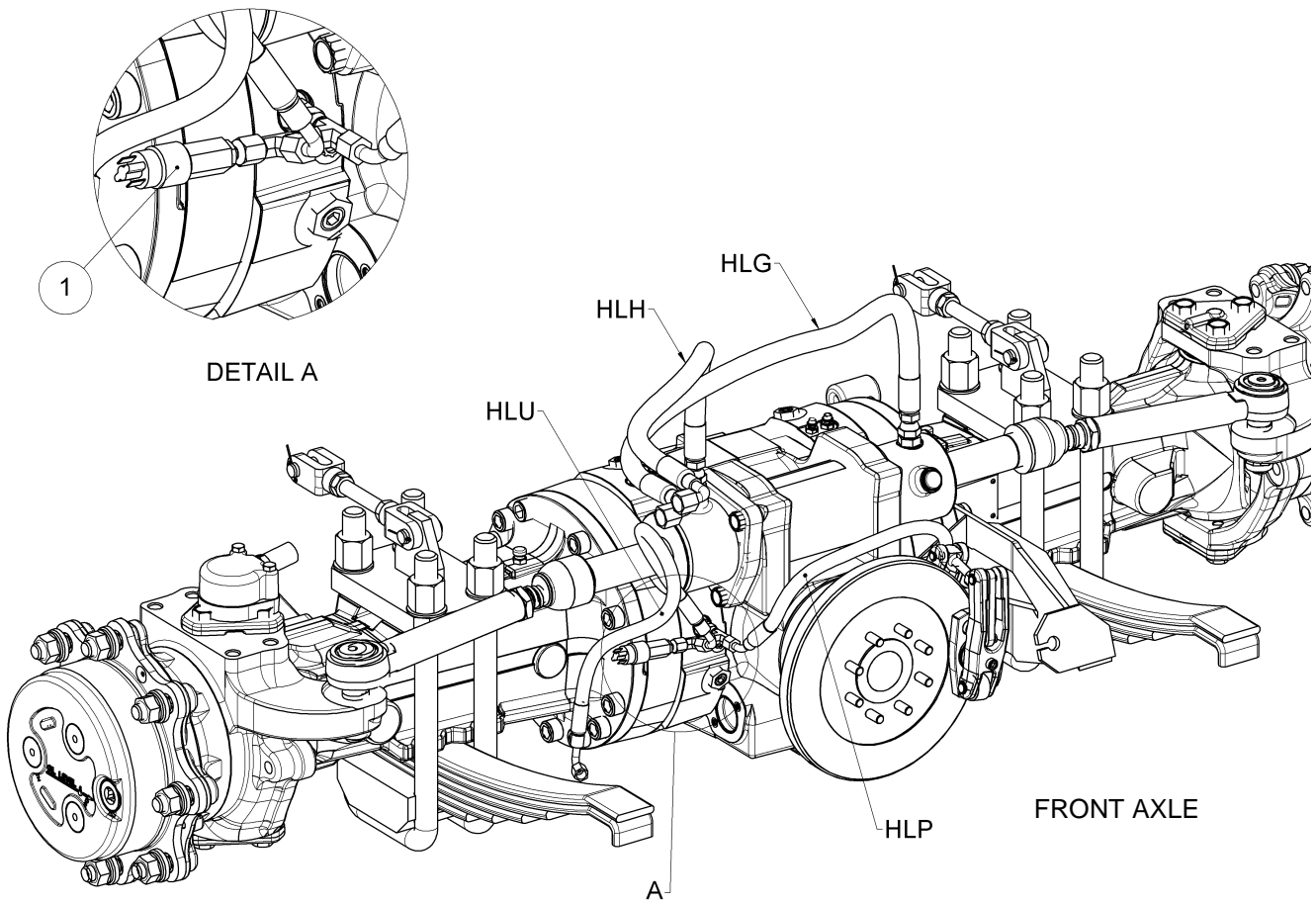

Item	Part Number	Qty.	Description
1	A-ES12-0468-1	1	BRAKE PRESSURE SWITCH

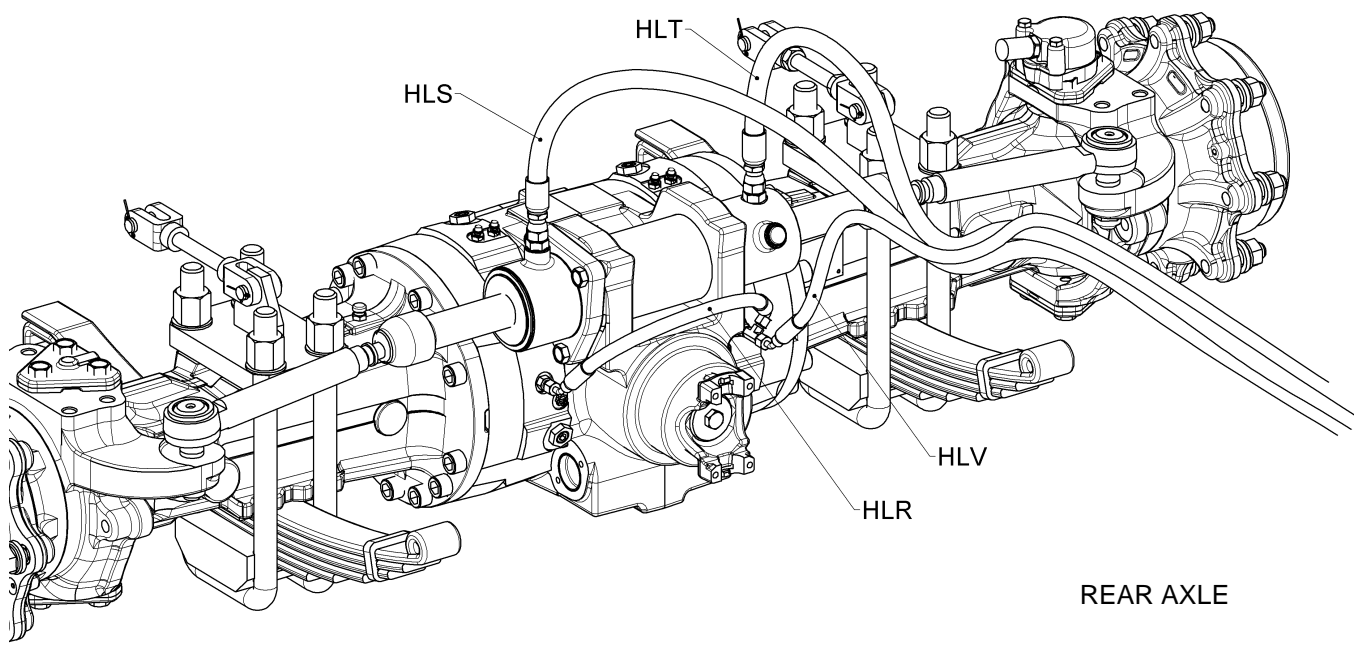

Axle Hoses

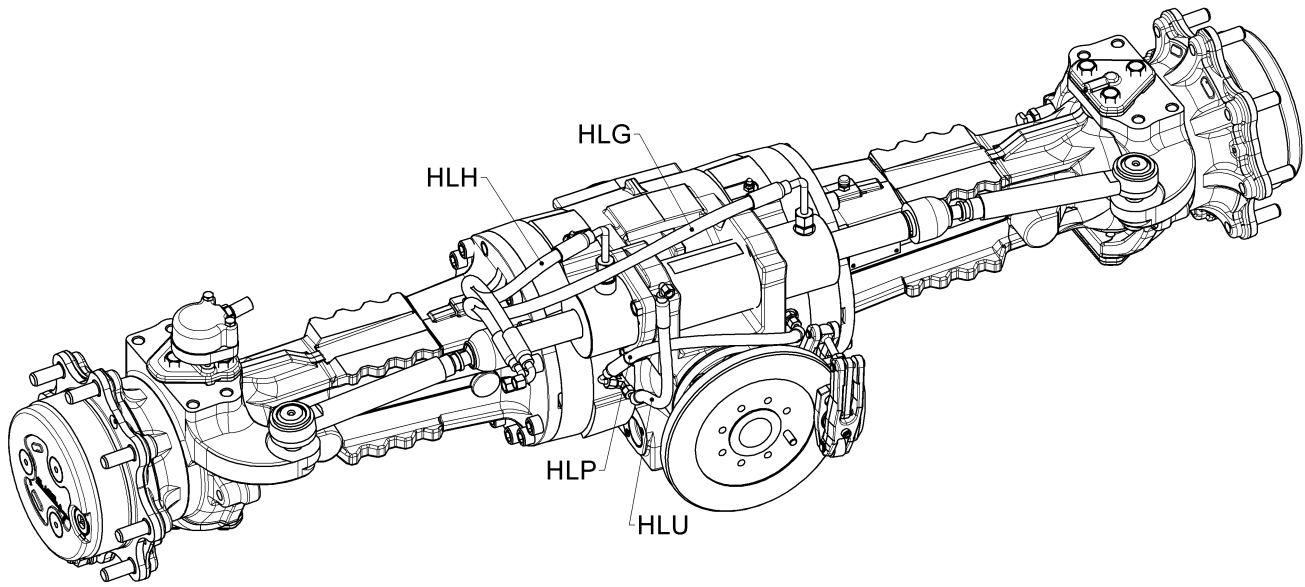

FRONT AXLE

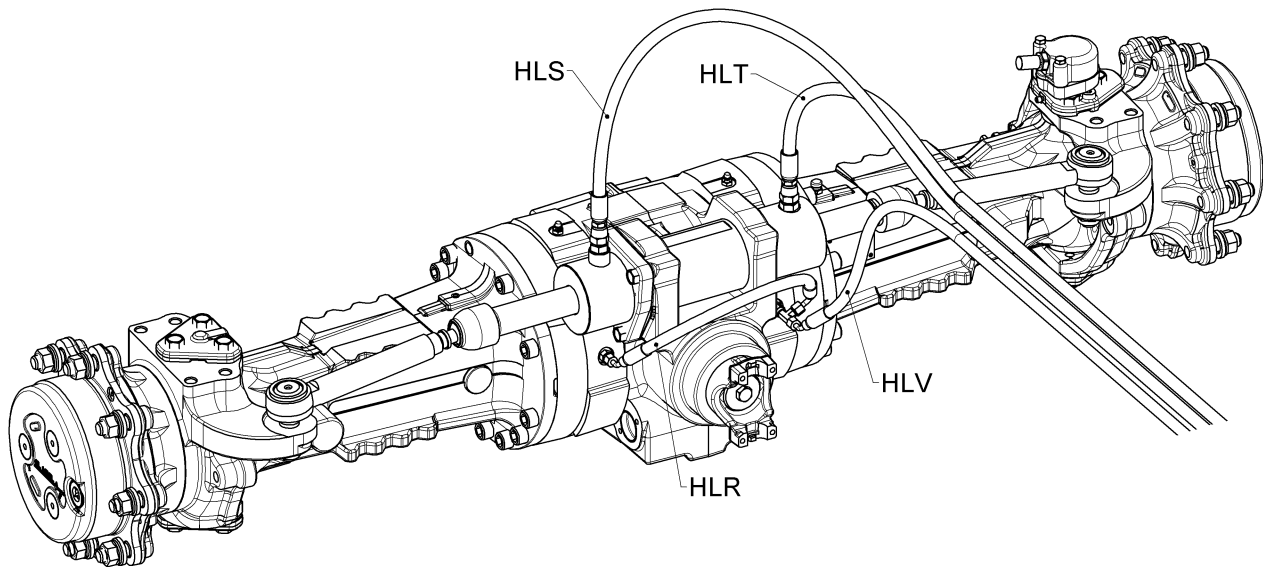

REAR AXLE

Revision Log

Rev	Date	Description	Appr.
A	17-Apr-2014	Original release for production	PRB
B	05-Sep-2014	Corrected accumulator pre-charge values	SEB
C	20-May-2015	Revised and rearranged pages in section. Updated for eTT12 rev G tractors.	DCM
D	26-Aug-2015	Added shift dampener hose (HLX) and fittings.	DCM
E	24-Aug-2016	Updated hydraulic hose schematic and fittings table	TFP

Table of Contents

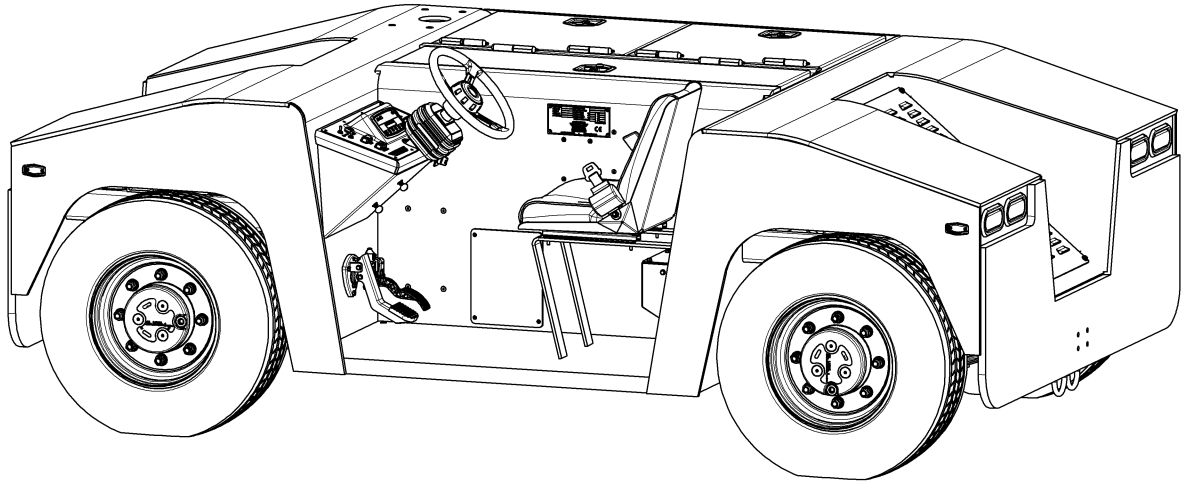

Section 8 - Operator Interface and Chassis System

Description	Page
Park Brake	8-2
Steering Valve, Column, Wheel	8-4
Dash Panel	8-5
Seats and Floor Mats	8-7
Charge Jack Cover	8-8
Body Cover Panels	8-10
Revision Log	8-14

Park Brake Handle, Cable

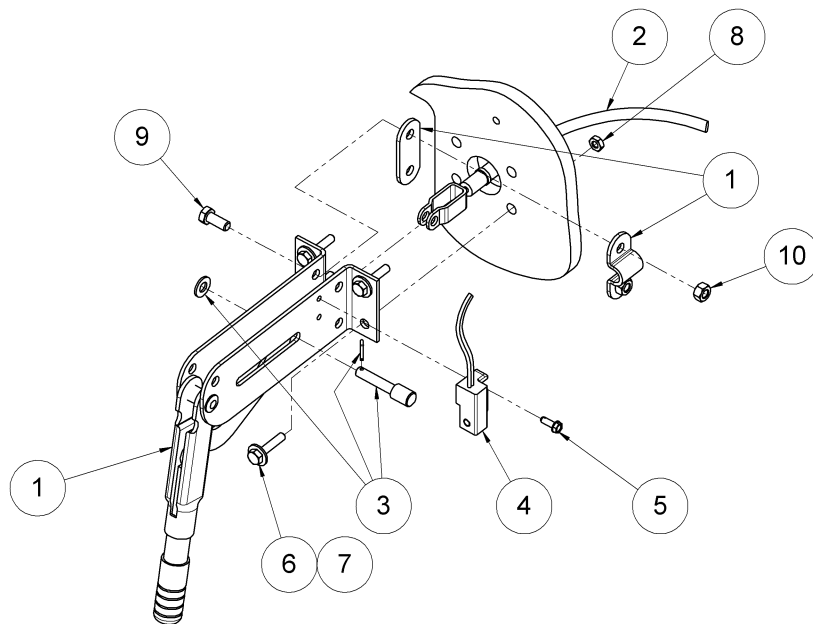

Item	Part Number	Qty.	Description
1	A-TT4-00141	1	PARK BRAKE HANDLE
2	A-ES12-0150	1	PARK BRAKE CABLE
3	81008429	1	PARK BRAKE CONTACT PIN
4	82050000	1	PROXIMITY SENSOR
5	82066700	1	SCREW, SELF-TAPPING, #12 X .5, TYPE B
6	NPN	4	HCS, 1/4-20 UNC X 1.25
7	NPN	4	FLAT WASHER, 1/4
8	NPN	4	LOCK NUT, 1/4-20 UNC
9	NPN	2	HCS, 5/16-18 UNC X .75
10	NPN	2	LOCK NUT, 5/16-18 UNC
N/A	DT04-2P	1	ELECTRICAL CONNECTOR (INSTALLED TO ITEM 4)
N/A	W2P	1	CONNECTOR LOCK (INSTALLED TO ITEM 4)
N/A	0460-215-16141	2	CONNECTOR PINS (INSTALLED TO ITEM 4)

Item 4 to be wired as shown below:

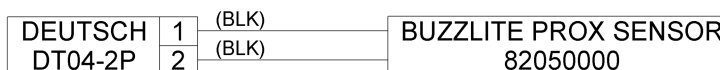

Park Brake Cable Routing

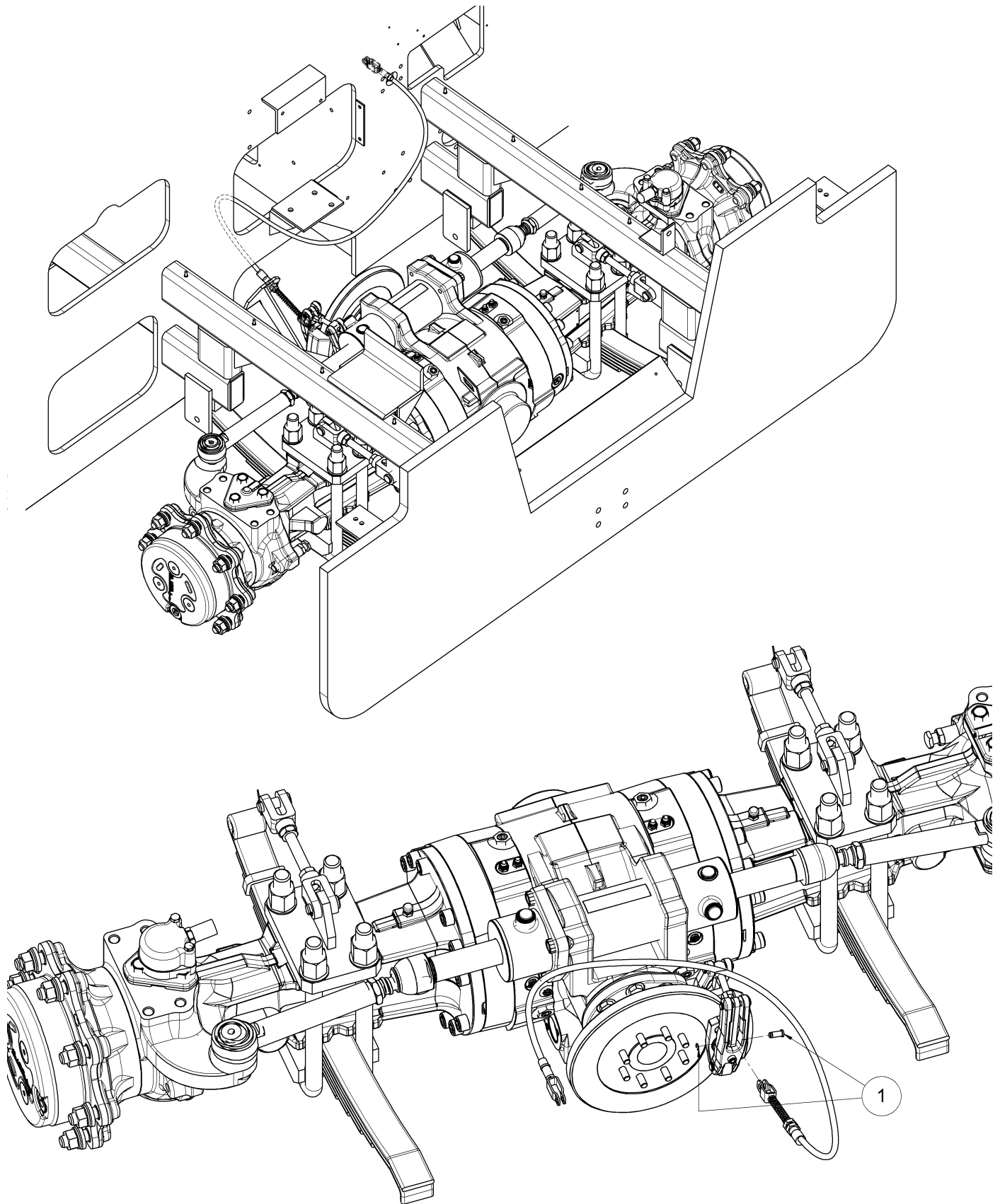

Item	Part Number	Qty.	Description
1	A-ES12-0152	1	CLEVIS PIN

Steering Valve, Column, Wheel

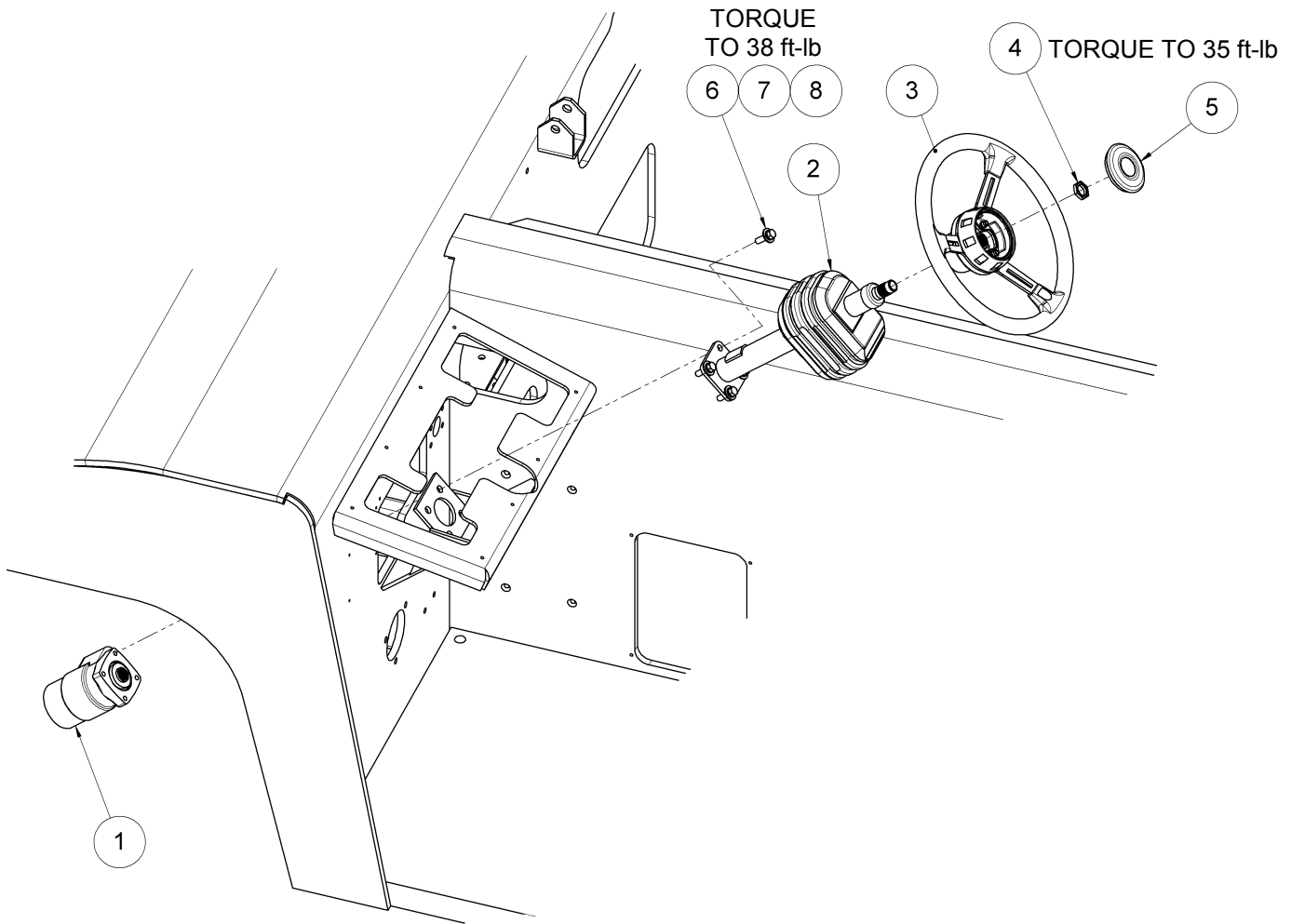

Item	Part Number	Qty.	Description
1	A-ES12-0457	1	STEER VALVE
2	A-ES12-0807	1	STEERING COLUMN
3	A-TN4-00809E	1	STEERING WHEEL
4	A-TT10-00813	1	WHEEL NUT, 13/16-20 UNEF
5	A-TT10-00811	1	HORN BUTTON
6	NPN	4	HCS, 3/8-16 UNC X 1.25
7	NPN	4	LOCK WASHER, 3/8
8	NPN	4	FLAT WASHER, 3/8

Dash Panel

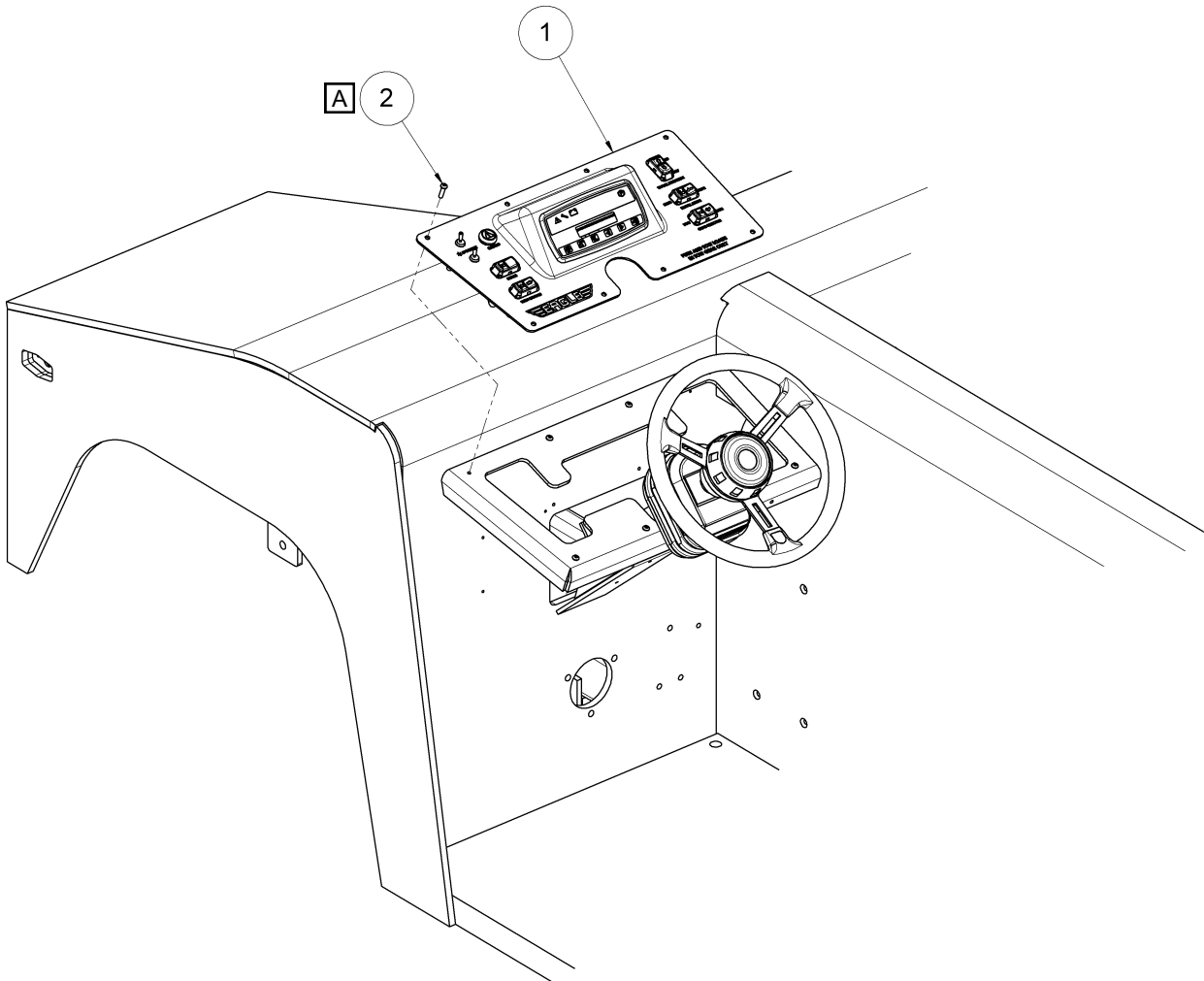

A Use Permatex® Anti-Seize Lubricant or equivalent.

Item	Part Number	Qty.	Description
1	NPN	1	DASH PANEL ASSEMBLY, (SEE SECTION 4)
2	NPN	8	BHCS, 1/4-20 UNC X 1, SS

Seats and Floor Mats

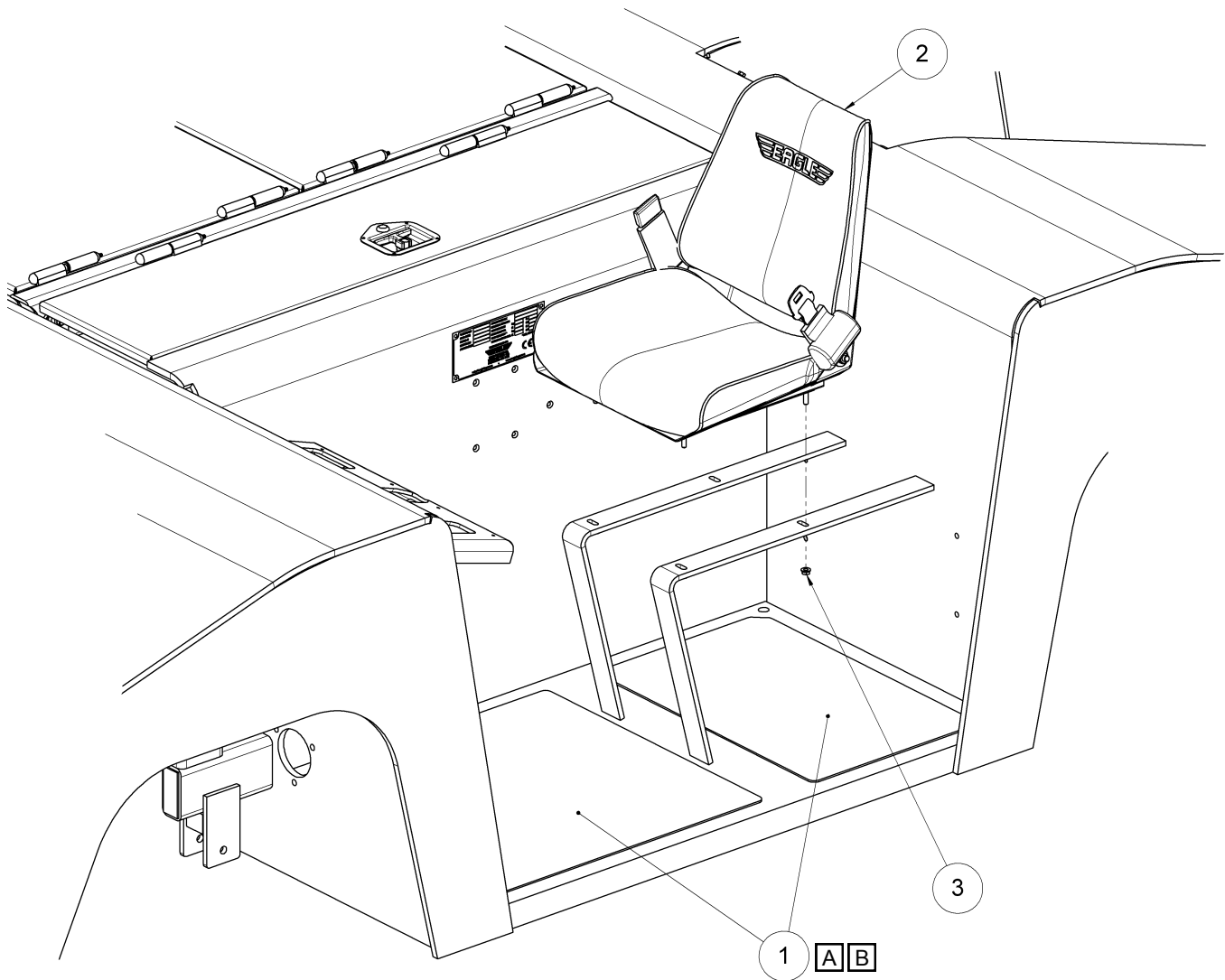

A Prime back surface of PVC decking with Bulldog® Adhesion Promoter or equivalent.

B Adhere to chassis with SEM 39337 Door Skin & SMC Adhesive or equivalent.

Item	Part Number	Qty.	Description
1	A-ES12-0820	1	FLOOR MAT KIT, ETT12
2	A-TT4-0048-1	1	STANDARD SEAT WITH SEATBELT
N/A	AE-OPT-0055-A	N/A	REPLACEMENT BOTTOM CUSHION, STANDARD SEAT
3	NPN	4	FLANGE NUT, SERRATED, 5/16-18 UNC (INCLUDED WITH ITEM 1)
N/A	E10000	N/A	REPLACEMENT SEAT BELT

Charge Jack Cover

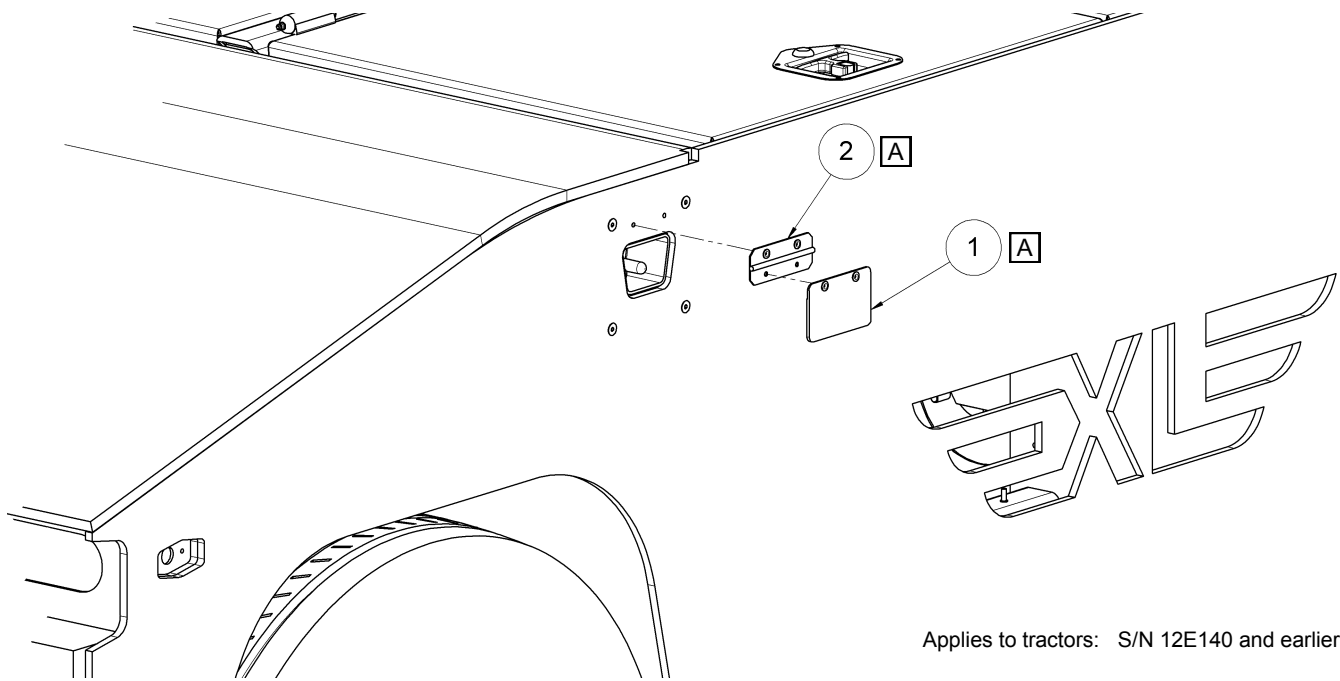

Applies to tractors: S/N 12E140 and earlier

A Items 1 and 2 are installed using Aluminum Pop Rivets, 3/16.

Item	Part Number	Qty.	Description
1	A-ES12-0109	1	BATTERY CHARGE JACK COVER (S/N 12E140 AND EARLIER)
2	NPN	1	HINGE, CHARGE JACK COVER

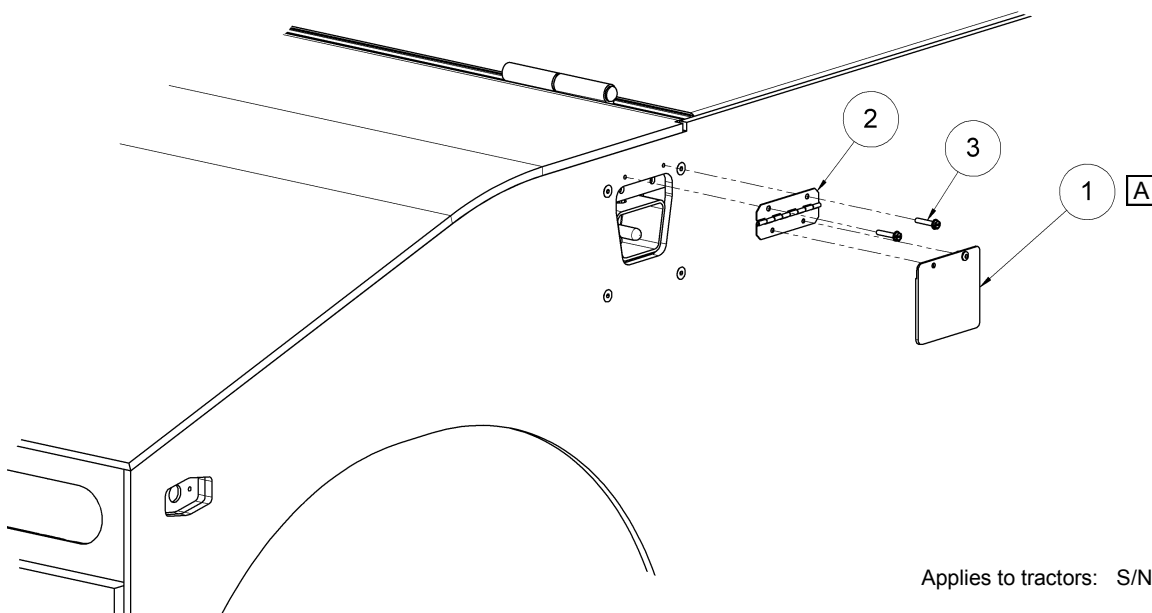

Applies to tractors: S/N 12E141 and 12E142

A Item installed using Aluminum Pop Rivets, 3/16.

Item	Part Number	Qty.	Description
1	ET12-02-004-SA	1	BATTERY CHARGE JACK COVER (S/N 12E141 AND 12E142)
2	NPN	1	HINGE, CHARGE JACK COVER
3	NPN	2	HCS, #10-32 UNF X 1

Charge Jack Cover

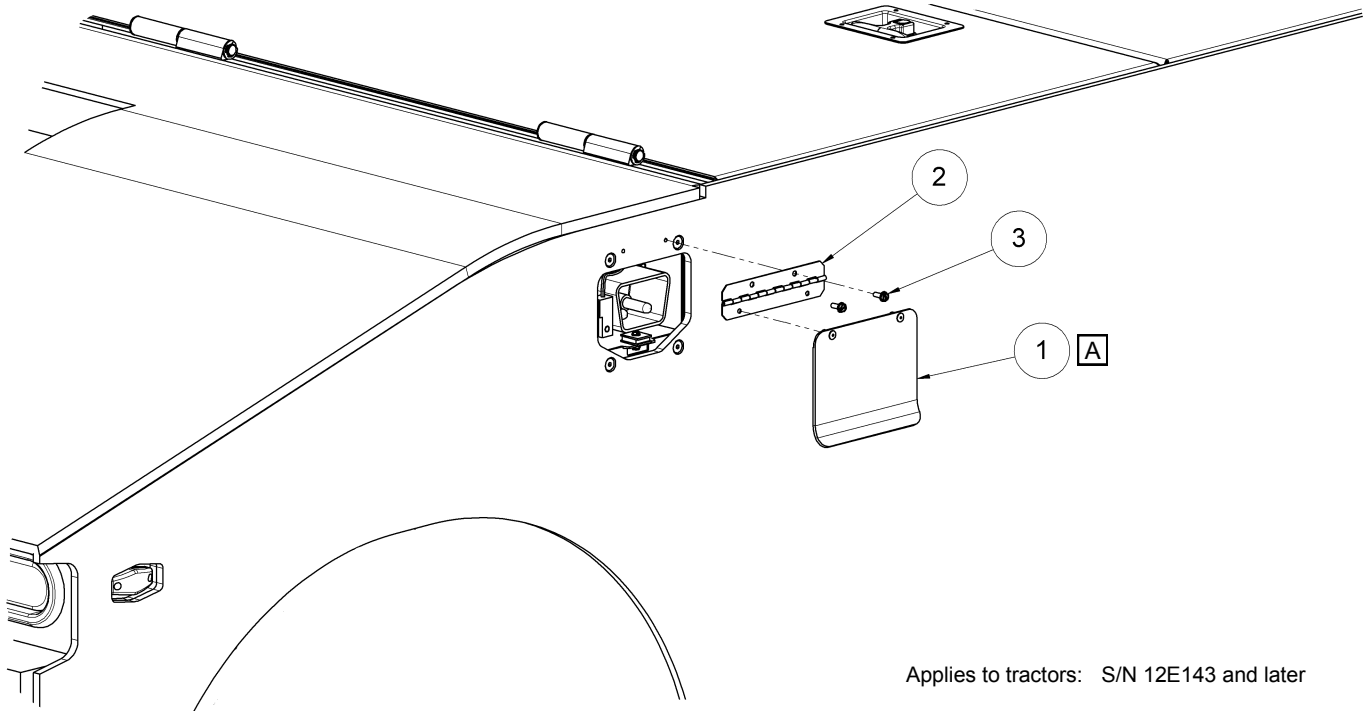

Applies to tractors: S/N 12E143 and later

A Item installed using Aluminum Pop Rivets, 3/16.

Item	Part Number	Qty.	Description
1	ET00-02-003-SA	1	BATTERY CHARGE JACK COVER (S/N 12E143 AND LATER)
2	ET00-02-004-SA	1	HINGE, CHARGE JACK COVER
3	NPN	2	HCS, #10-32 UNF X .5

Body Cover Panels

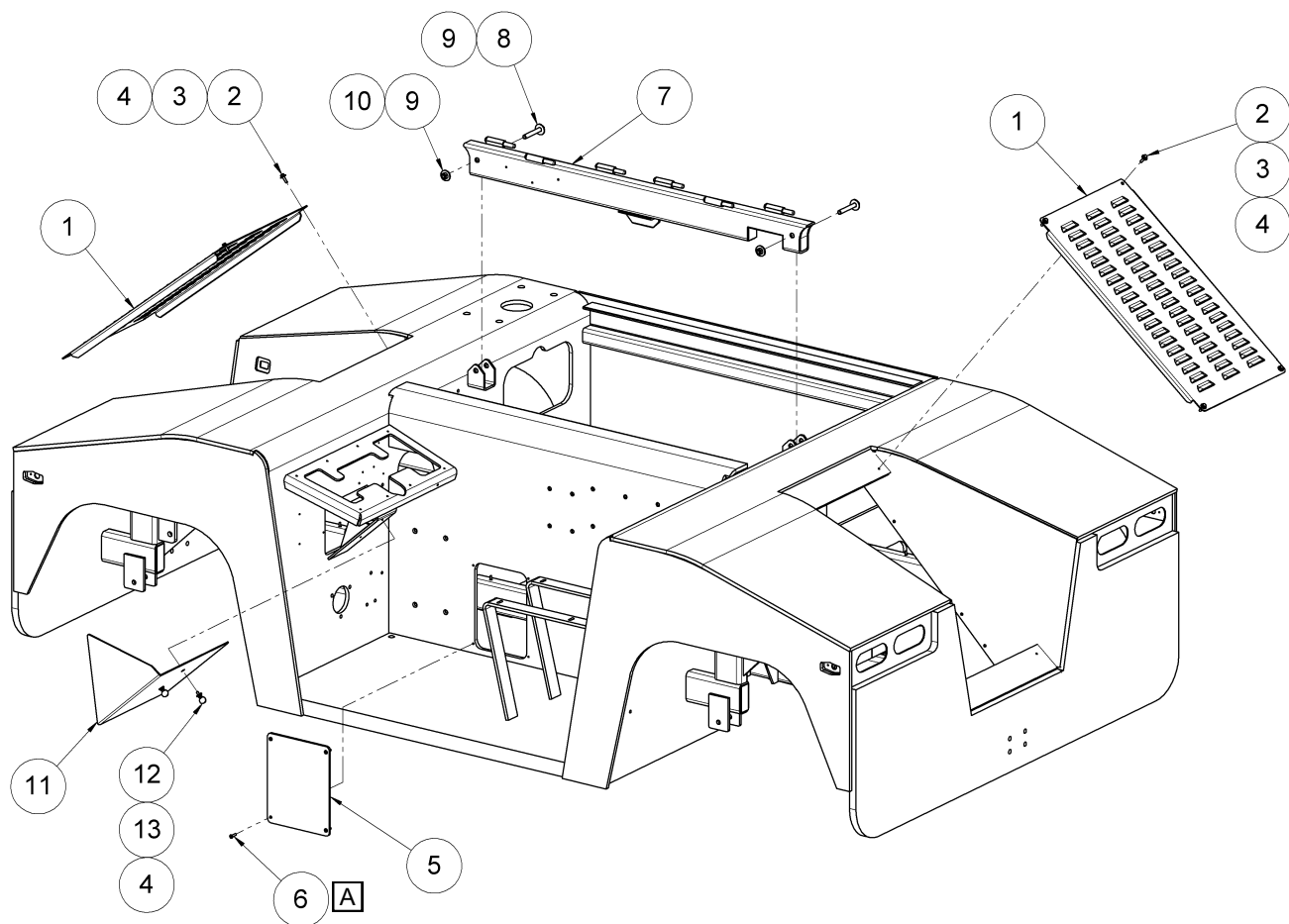

A Use Permatex® Anti-Seize Lubricant or equivalent.

Item	Part Number	Qty.	Description
1	A-ES12-0325	2	LOUVER
2	NPN	8	HCS, 1/4-20 UNC X 1
3	NPN	8	LOCK WASHER, 1/4
4	NPN	9	FLAT WASHER, 1/4
5	A-ES12-0335	1	CENTER ACCESS PANEL COVER
6	NPN	4	BHS, 1/4-20 UNC X 1, SS
7	A-ES12-0305	1	PANEL SUPPORT WELDMENT
8	NPN	4	HCS, 1/2-13 UNC X 3.5
9	NPN	8	FLAT WASHER, 1/2
10	NPN	4	LOCK NUT, 1/2-13 UNC
11	A-ES12-0330	1	DASH WIRING COVER
12	NPN	2	THUMB SCREW, 1/4-20 UNC X .75
13	NPN	2	FLANGE NUT, 1/4-20 UNC

Body Cover Panels

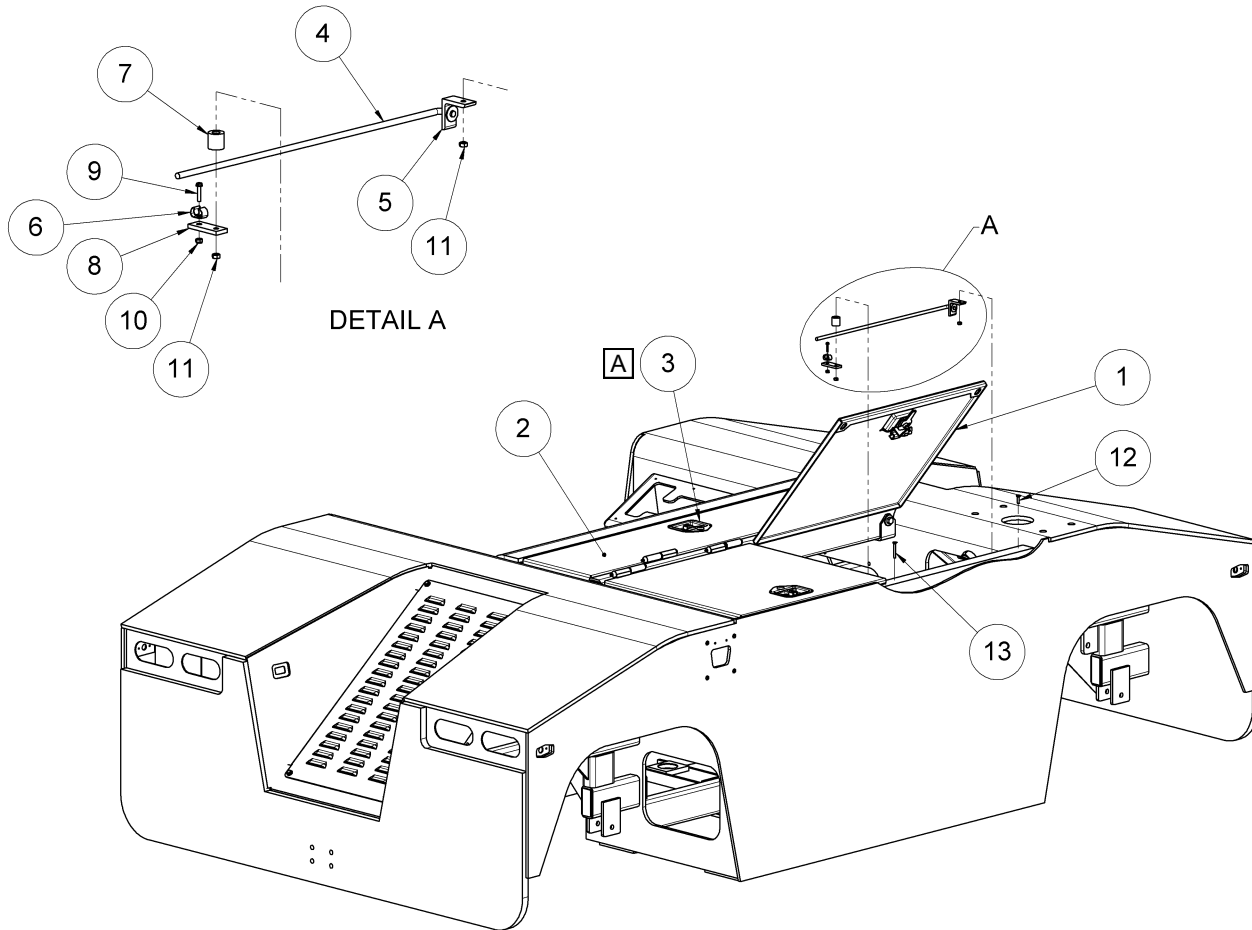

A Items 3 is installed using Aluminum Pop Rivets, 3/16.

Item	Part Number	Qty.	Description
1	A-ES12-0320	2	BATTERY HOOD
2	A-ES12-0310	1	MOTOR COVER
3	C-TT4-0012-3	3	LOCKING T-HANDLE
4	SH-TT8-0012-3	2	HOOD PROP ROD
5	SH-TT-0012-4	2	HOOD PROP ANGLE BRACKET
6	1723A21	2	HOOD PROP CLIP
7	NPN	2	SPACER, Ø1.0 OD X 1.0 LONG
8	SH-TT-0012-5	2	HOOD PROP CLIP BRACKET
9	NPN	2	HCS, #10-32 UNF X 1
10	NPN	2	LOCK NUT, #10-32 UNF
11	NPN	4	LOCK NUT, 1/4-20 UNC
12	NPN	2	SHCS, 1/4-20 UNC X 1
13	NPN	2	SHCS, 1/4-20 UNC X 2

Body Cover Panels

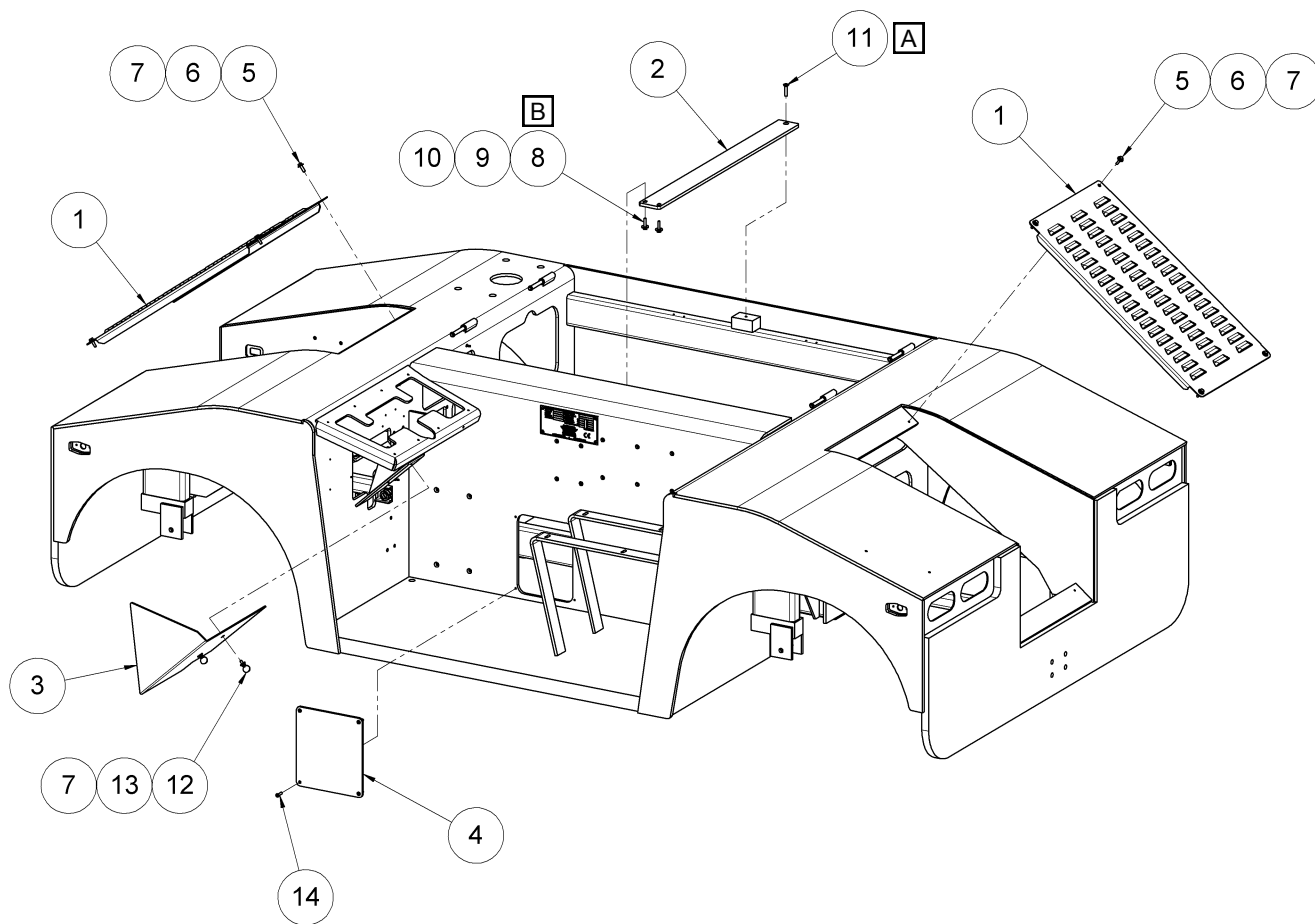

A Use Permatex® Anti-Seize Lubricant or equivalent.

B Install specified components using Loctite® Threadlocker Blue 242® thread retaining compound or comparable.

Item	Part Number	Qty.	Description
1	ES12-0325	2	LOUVER
2	ET12-02-003-SA	1	HOOD REST WELDMENT
3	A-ES12-0330	1	DASH WIRING COVER
4	A-ES12-0335	1	CENTER ACCESS PANEL COVER
5	NPN	10	HCS, 1/4-20 UNF X 1
6	NPN	10	LOCK WASHER, 1/4
7	NPN	12	FLAT WASHER, 1/4
8	NPN	2	HCS, 5/16-18 UNF X 1.25
9	NPN	2	LOCK WASHER, 5/16
10	NPN	2	FLAT WASHER, 5/16
11	NPN	1	FHSCS, 5/16 UNC X 1.5
12	NPN	2	THUMB SCREW, 1/4-20 UNC X .75
13	NPN	2	FLANGE NUT, 1/4-20 UNC
14	NPN	4	BHS, 1/4-20 UNC X 1, SS

Body Cover Panels

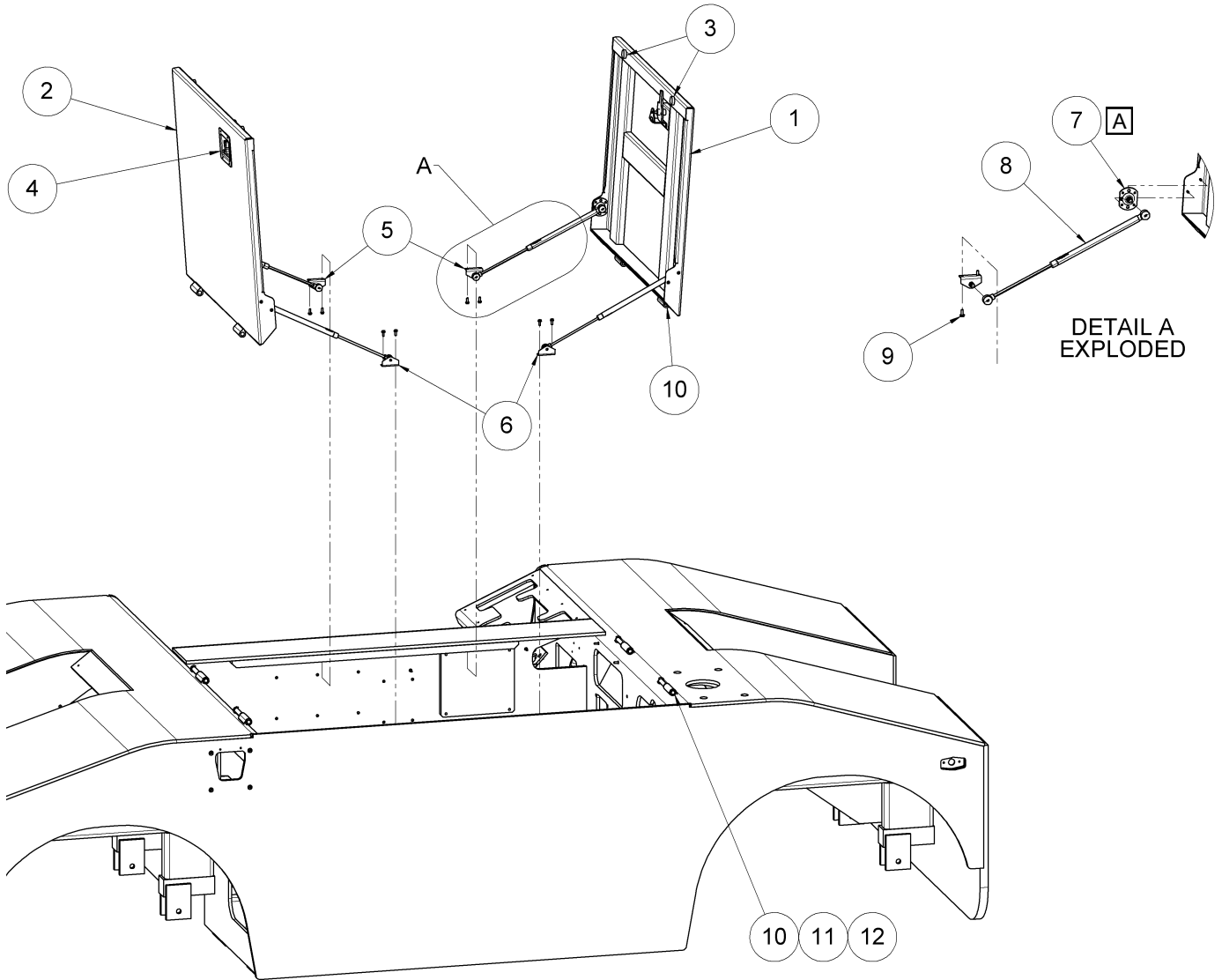

A Items 7 is installed using Pop Rivets, 5/32 X .375.

Item	Part Number	Qty.	Description
1	ET12-02-002-SA	1	FRONT BATTERY HOOD
2	ET12-02-002-SB	1	REAR BATTERY HOOD
3	NVSP-21-004-CA	4	RUBBER PRESS-IN BUMPER
4	C-TT4-0012-2	2	T-HANDLE LATCH
5	SATS-14-002-CA	2	GAS SHOCK MOUNT
6	NVSP-24-029-CA	2	GAS SHOCK MOUNT
7	SATS-14-003-CA	4	GAS SHOCK MOUNT
8	ET12-14-004-CA	4	GAS SHOCK
9	NPN	8	HCS, #10-32 UNF X .5
10	NVSP-24-007-CA	4	HINGE SLEEVE, PAIR
11	NVSP-24-030-SA	4	HINGE PIN
12	NVSP-24-031-SA	8	RETAINING RING

Revision Log

Rev	Date	Description	Appr.
A	22-Apr-2014	Original release for production	PRB
B	28-Apr-2014	Added part number for Dash Wiring Cover. Corrected part number of Panel Support Weldment.	SEB
C	09-Mar-2015	Added information for Rev G tractors.	DCM
D	27-July-2016	Added new charge jack cover	TFP
E	29-Nov-2016	Corrected parking brake proximity sensor part number	PRB

Section 9 - Optional Equipment	
Description	Page
Spotlights	9-2
Post Mounted Beacon	9-4
Backup Alarm	9-5
Turn Signals	9-6
Dual Battery Option - eTT16 only	9-8
Cab Heater - eTT8/eTT12	9-13
PVC Decking	9-16
Revision Log	9-18

Spotlights

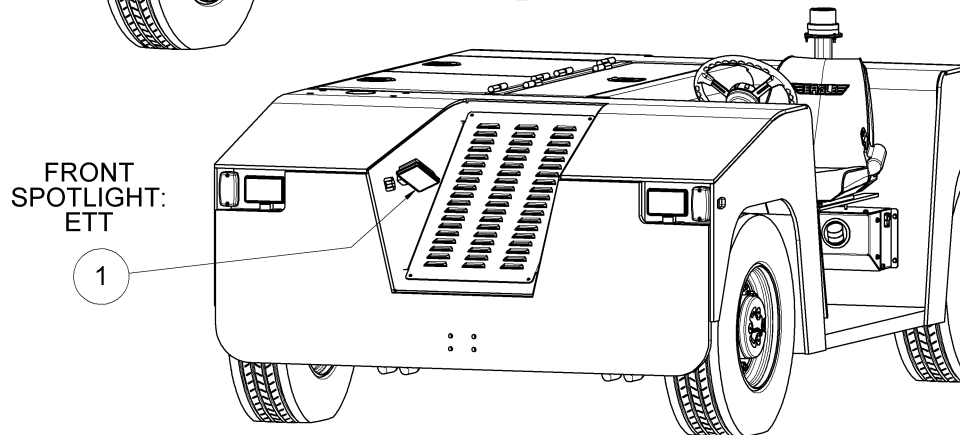
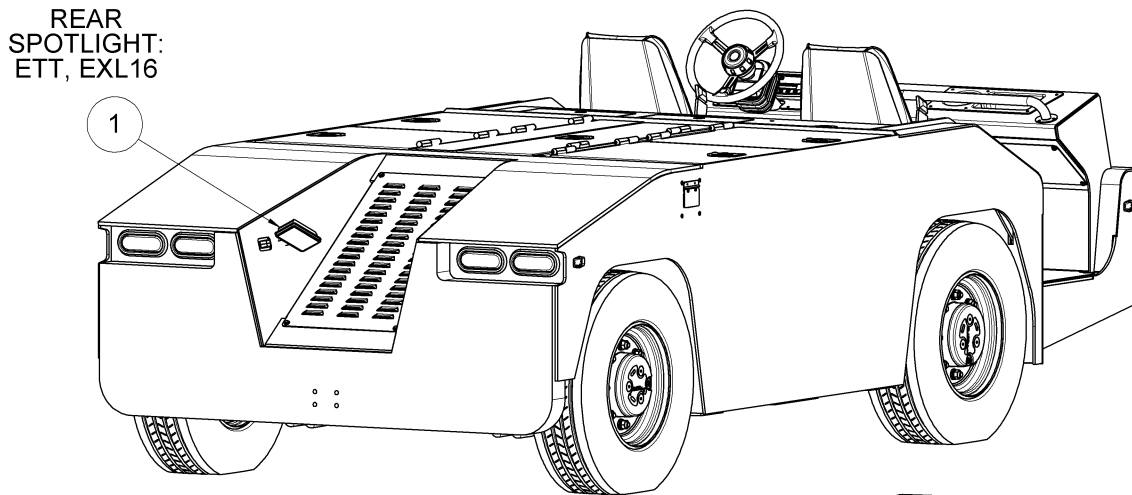
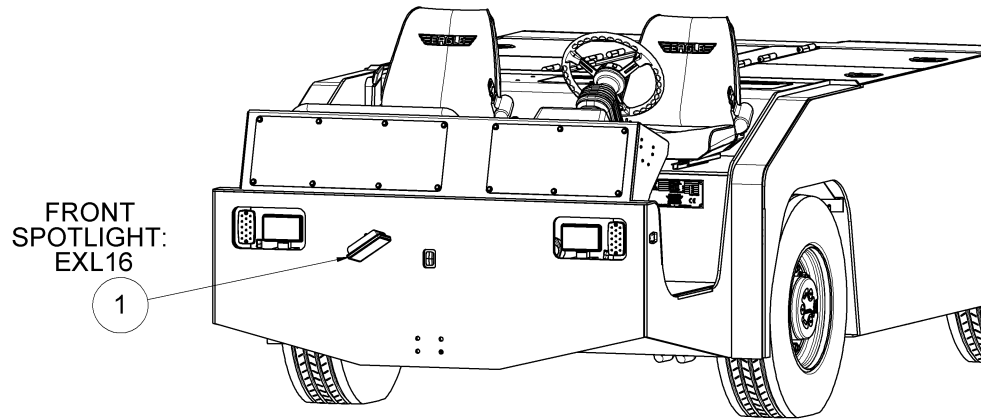

Item	Part Number	Qty.	Description
1	A-TT4-00291-LED	-	SPOTLIGHT, LED (MOUNTING HARDWARE INCLUDED)
2	NVSP-14-008-CA	-	TOGGLE SWITCH, LIT TIP (SEE DASH PANEL ASY, SECTION 4)
N/A	DT04-2P	-	ELECTRICAL CONNECTOR (INSTALLED TO ITEM 1)
N/A	W2P	-	CONNECTOR LOCK (INSTALLED TO ITEM 1)
N/A	0460-215-16141	-	CONNECTOR PINS (INSTALLED TO ITEM 1)
N/A	DT04-4P	-	ELECTRICAL CONNECTOR (INSTALLED TO ITEM 2)
N/A	W4P	-	CONNECTOR LOCK (INSTALLED TO ITEM 2)
N/A	0460-215-16141	-	CONNECTOR PINS (INSTALLED TO ITEM 2)
N/A	114017	-	CAVITY PLUG (INSTALLED TO ITEM 2)
N/A	NPN	-	QUICK DISCONNECT, FEMALE, 1/4 (INSTALLED TO ITEM 2)

Spotlights

Item 1 to be wired as shown below:



Item 2 to be wired as shown below (for tractor S/N's: 12E118 / 8E113 / 16E103 and later only (excluding 12E124)):

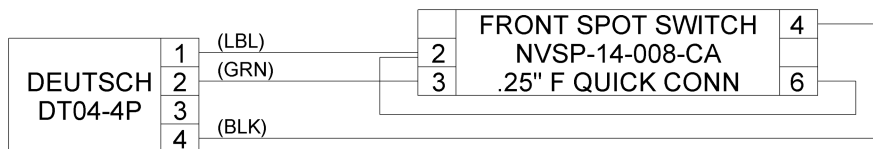

FRONT SPOT ONLY

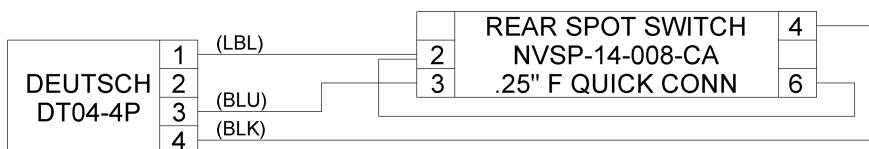

REAR SPOT ONLY

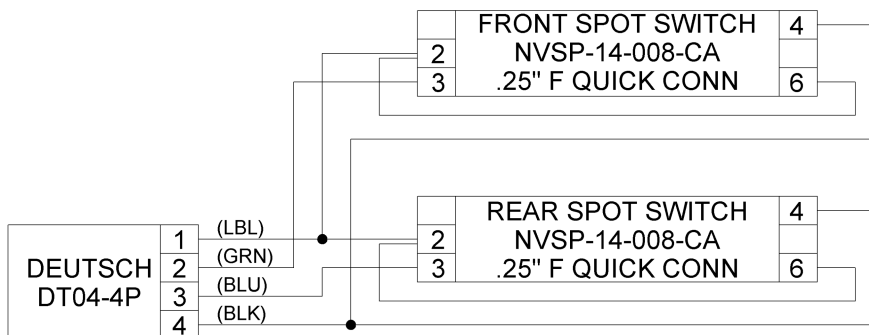

FRONT AND REAR SPOT

Post Mounted Beacon

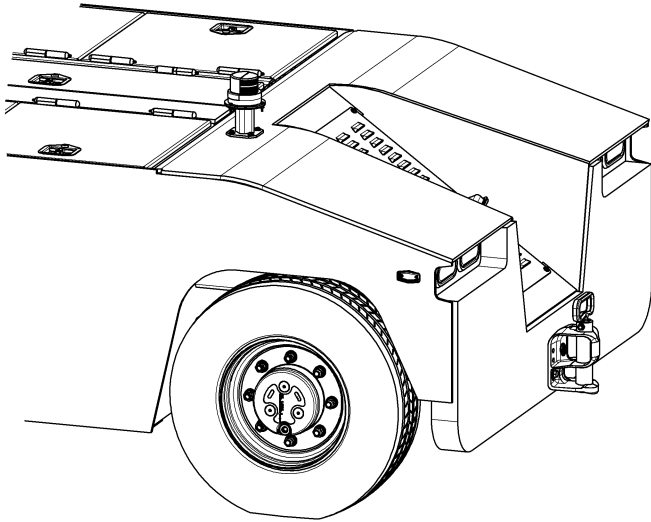

INSTALLED TO LEFT REAR FENDER

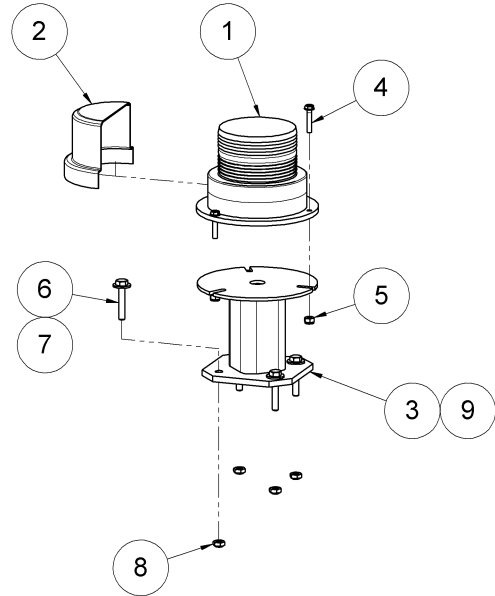

Item	Part Number	Qty.	Description
1	AE-OPT-0007-LED	1	AMBER STROBE BEACON, LED
2	AE-OPT-0009-LED	1	HALF COVER, LED BEACON
3	AE-OPT-0082-LED	1	BEACON POST, LED
4	NPN	3	HCS, #10-32 UNC X 1
5	NPN	3	LOCK NUT, #10-32 UNC
6	NPN	4	HCS, 1/4-20 UNC X 1.5
7	NPN	4	FLAT WASHER, 1/4
8	NPN	4	LOCK NUT, 1/4-20 UNC
N/A	DT04-2P	1	ELECTRICAL CONNECTOR (INSTALLED TO ITEM 1)
N/A	W2P	1	CONNECTOR LOCK (INSTALLED TO ITEM 1)
N/A	0460-215-16141	2	CONNECTOR PINS (INSTALLED TO ITEM 1)

Item 1 to be wired as shown below:



Backup Alarm

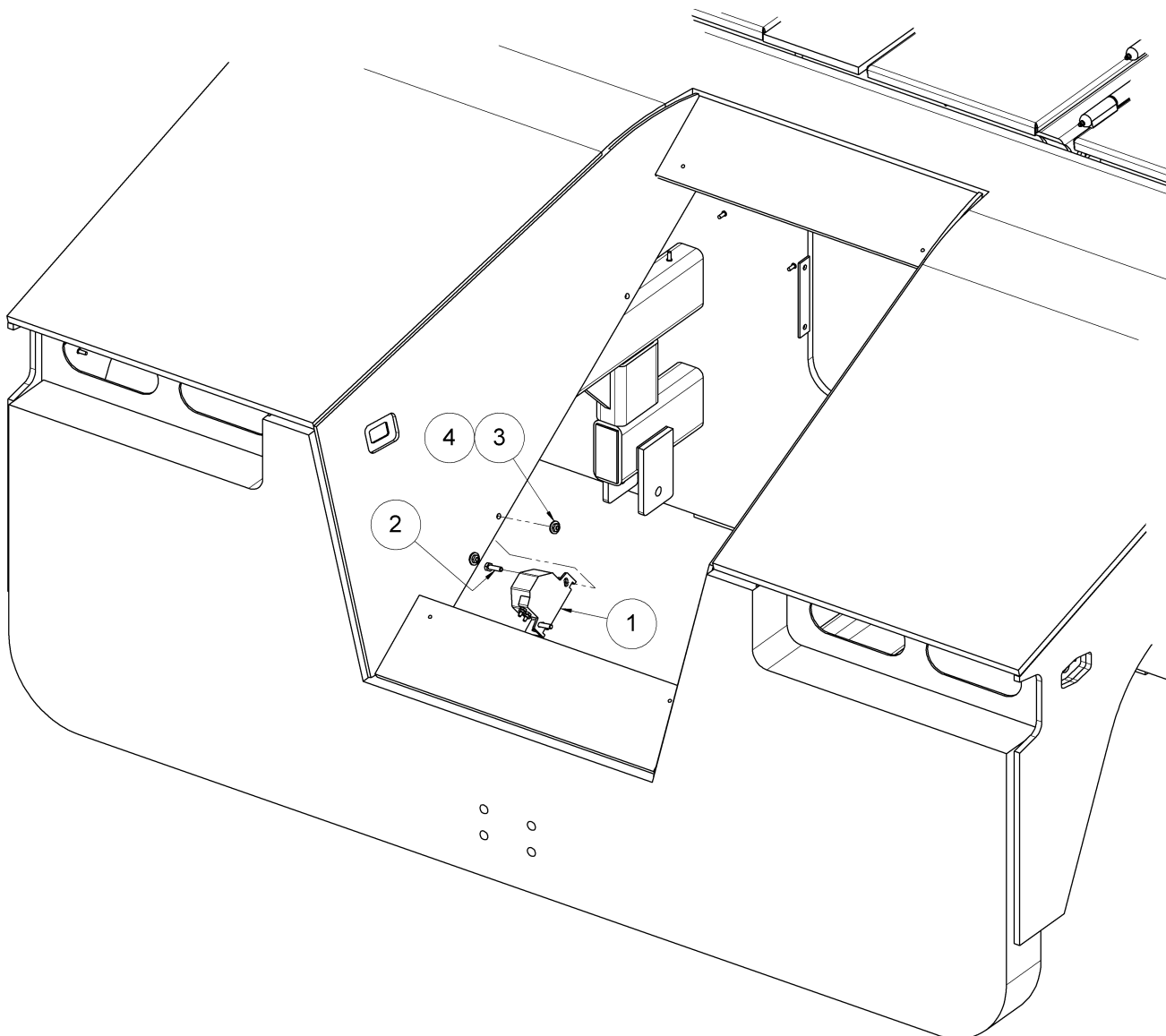

Item	Part Number	Qty.	Description
1	AE-OPT-0001	1	BACKUP ALARM
2	NPN	3	HCS, 1/4-20 UNC X 1
3	NPN	3	FLAT WASHER, 1/4
4	NPN	3	LOCK NUT, 1/4-20 UNC
N/A	DT04-2P	1	ELECTRICAL CONNECTOR (INSTALLED TO ITEM 1)
N/A	W2P	1	CONNECTOR LOCK (INSTALLED TO ITEM 1)
N/A	0460-215-16141	2	CONNECTOR PINS (INSTALLED TO ITEM 1)
N/A	NPN	2	RING TERMINAL, #10 (INSTALLED TO ITEM 1)

Item 1 to be wired as shown below:

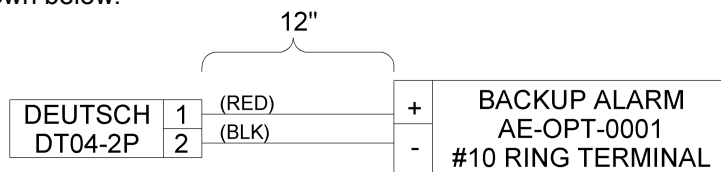

Turn Signals

This page applies to unit S/N's: 12E118 / 8E113 / 16E103 and later only (excluding 12E124)

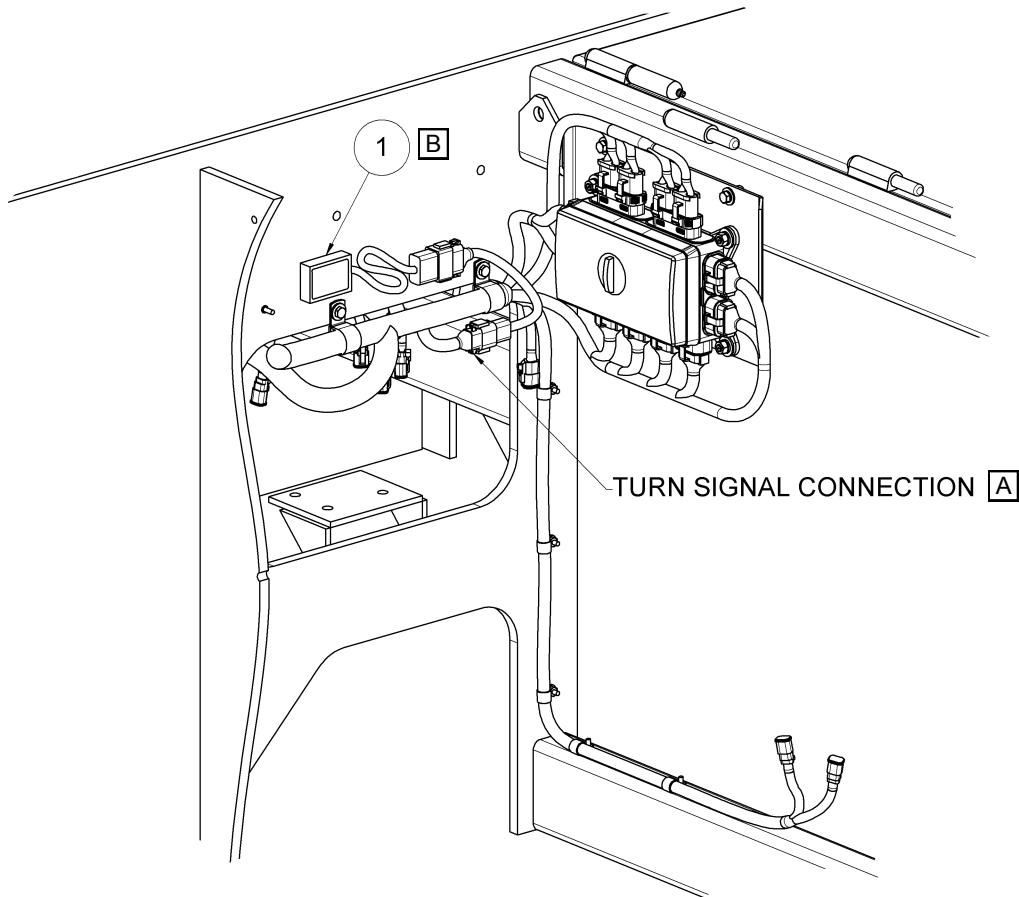

A Turn signal harness is routed through tractor to switch base in dash panel.

B Adhere to sheet metal using included double-sided adhesive.

Item	Part Number	Qty.	Description
1	NVSP-31-004-CA	1	TURN SIGNAL MODULE
2	NVSP-14-001-CE	1	MOM-OFF-MOM SWITCH BASE (SEE DASH PANEL ASY, SECTION 4)
3	NVSP-14-002-CA	1	TURN SIGNAL ACTUATOR (SEE DASH PANEL ASY, SECTION 4)
N/A	DT04-12PA	1	ELECTRICAL CONNECTOR (INSTALLED TO ITEM 1)
N/A	W12P	1	CONNECTOR LOCK (INSTALLED TO ITEM 1)
N/A	0460-215-16141	9	CONNECTOR PINS (INSTALLED TO ITEM 1)
N/A	114017	3	CAVITY PLUG (INSTALLED TO ITEM 1)
N/A	DT06-12SA	1	ELECTRICAL CONNECTOR
N/A	W12S	1	CONNECTOR LOCK
N/A	0462-209-16141	9	CONNECTOR PINS
N/A	114017	3	CAVITY PLUG
N/A	DTM04-08PA	1	ELECTRICAL CONNECTOR
N/A	WM-8P	1	CONNECTOR LOCK
N/A	0460-202-20141	7	CONNECTOR PINS
N/A	0413-204-2005	1	CAVITY PLUG
N/A	28-5637-2	1	SWITCH CONNECTOR (CONNECTED TO ITEM 2)
N/A	12015870	7	CONNECTOR PINS

Turn Signals

This page applies to unit S/N's: 12E118 / 8E113 / 16E103 and later only (excluding 12E124)

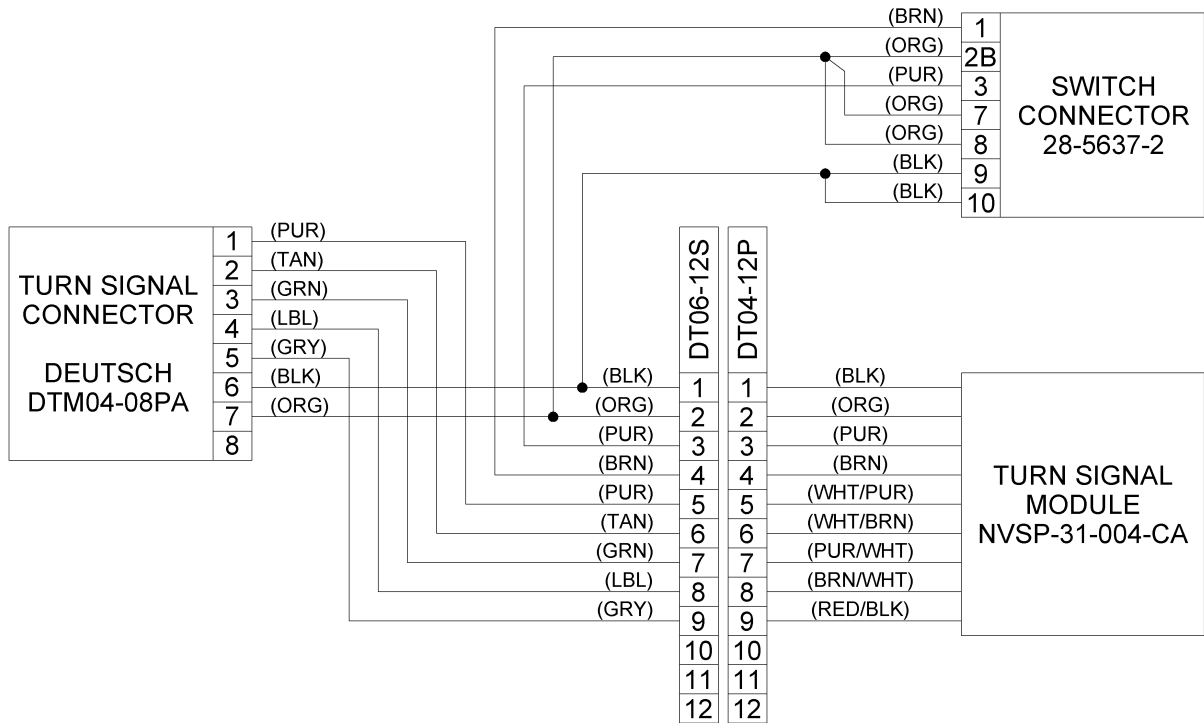
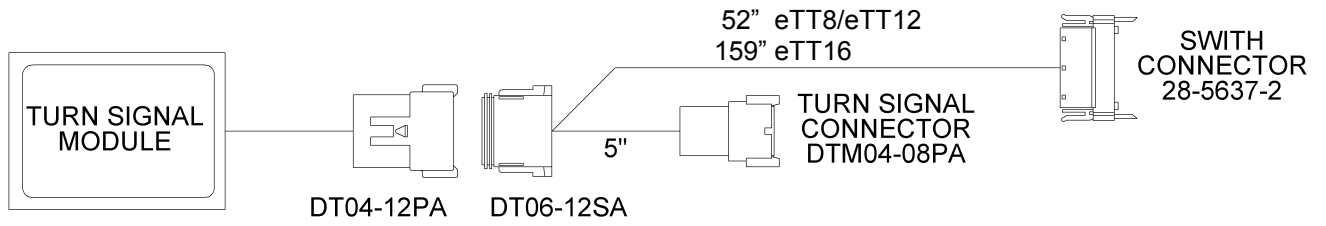

Dual Battery Option - eTT16 only

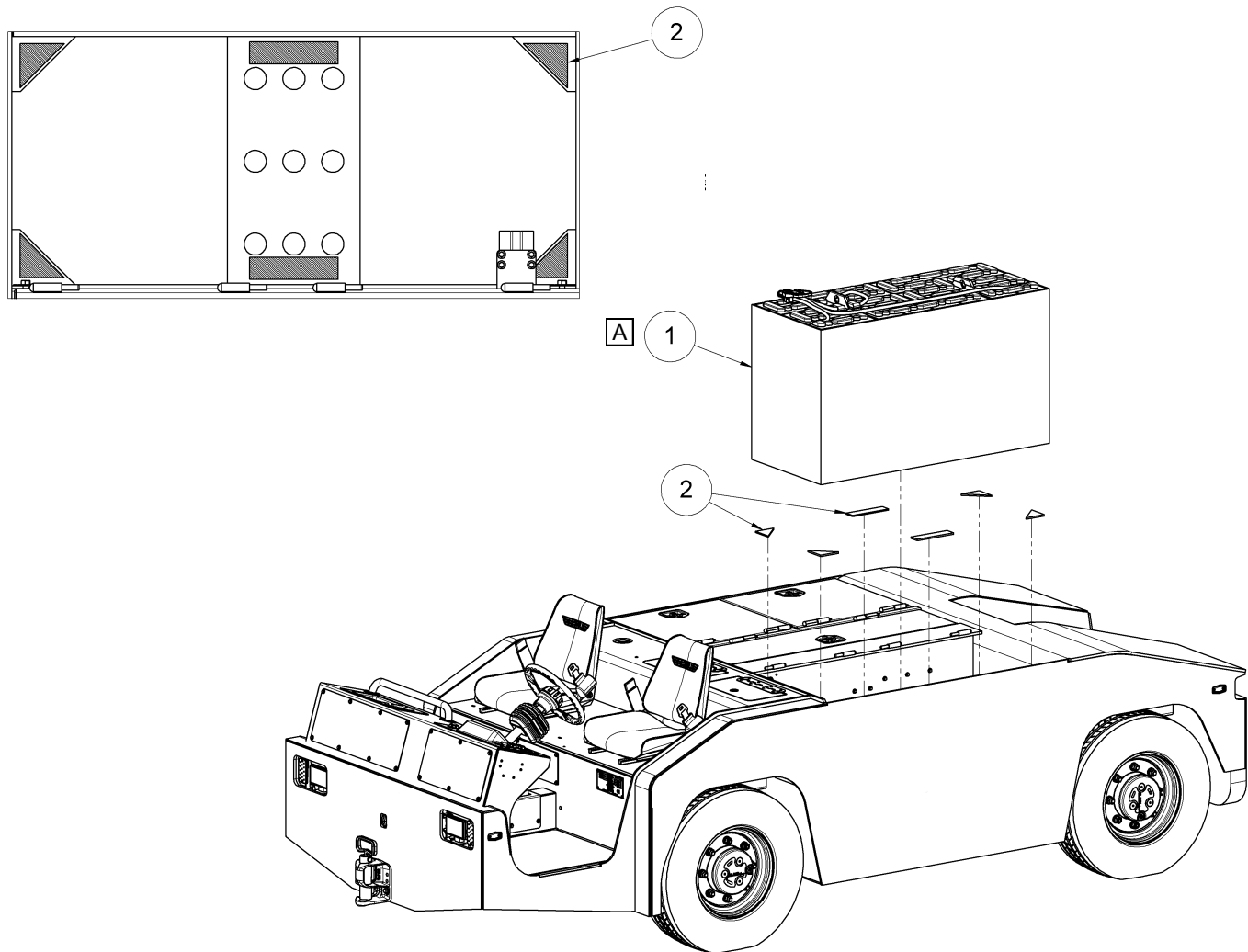

A Battery must be installed before hoods, gas shocks, and prop rods and before mating connector is mounted.

Item	Part Number	Qty.	Description
1	A-ES12-1200	1	TRACTION BATTERY, 80V, 625 AH
2	A-ES12-0448	.5	SELF-ADHESIVE BATTERY PAD (APPLY AS SHOWN)

Dual Battery Option - eTT16 only

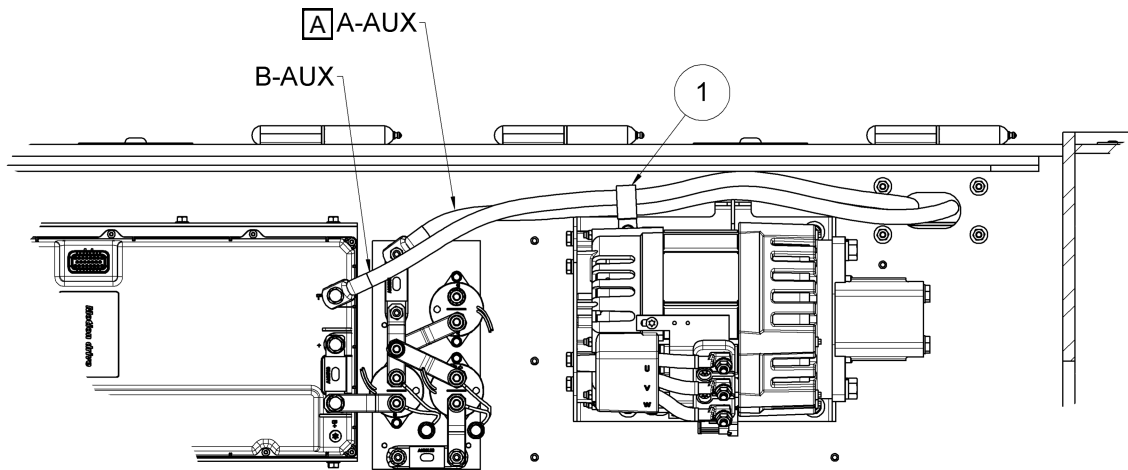

A Terminating lug in fuse holder must be replaced with 1.5 inch long bolt to secure A-AUX.

Item	Part Number	Qty.	Description
1	NPN	1	CUSHIONED LOOP CLAMP

Dual Battery Option - eTT16 only

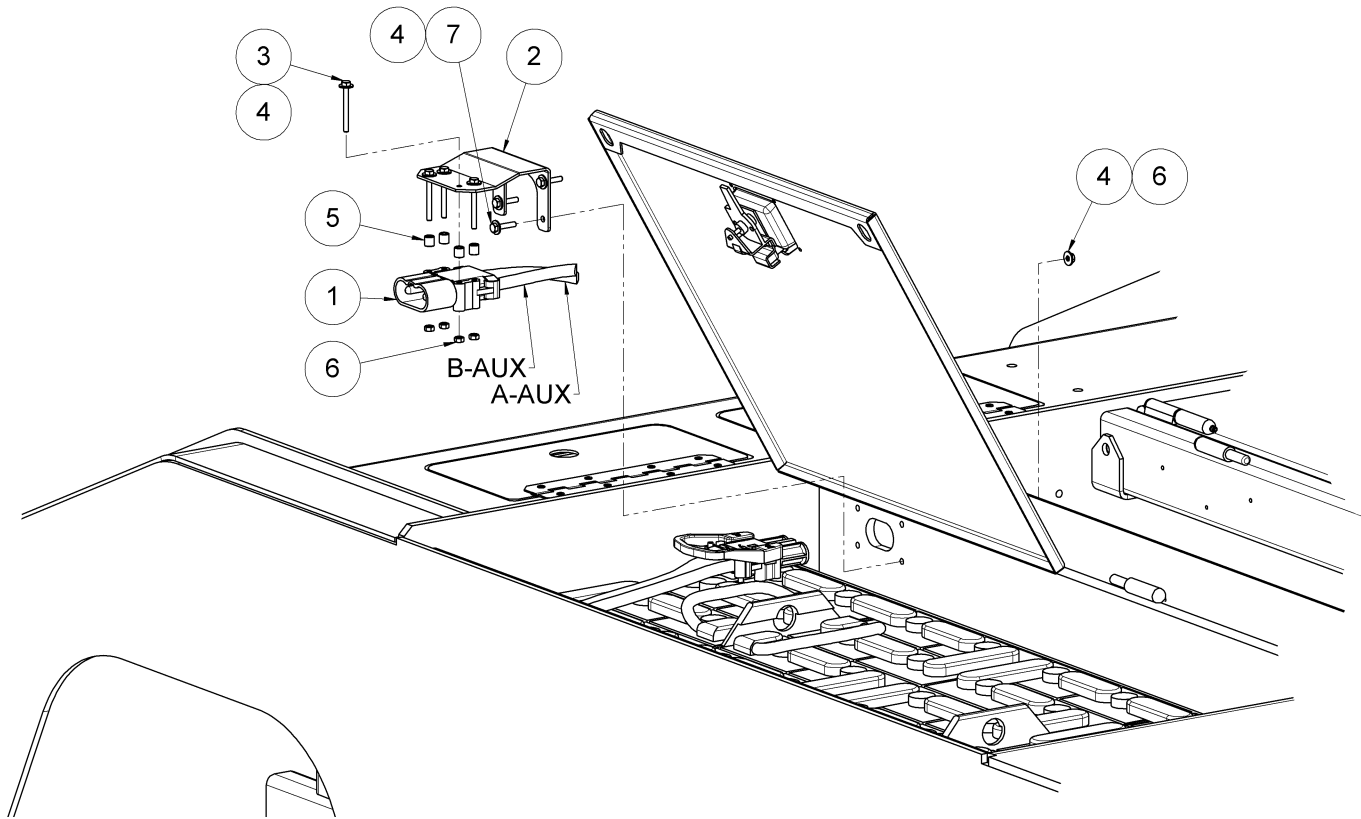

Item	Part Number	Qty.	Description
1	A-ES12-0447	1	EURO/DIN BATTERY CONNECTOR KIT
2	A-EXL16-0119	1	SECOND BATTERY EURO CONNECTOR BRACKET
3	NPN	4	HCS, 1/4-20 UNC X 2.5
4	NPN	12	FLAT WASHER, 1/4
5	NPN	4	SPACER, Ø.5 OD X .5 TALL
6	NPN	8	LOCK NUT, 1/4-20 UNC
7	NPN	4	HCS, 1/4-20 UNC X 1.25

Dual Battery Option - eTT16 only

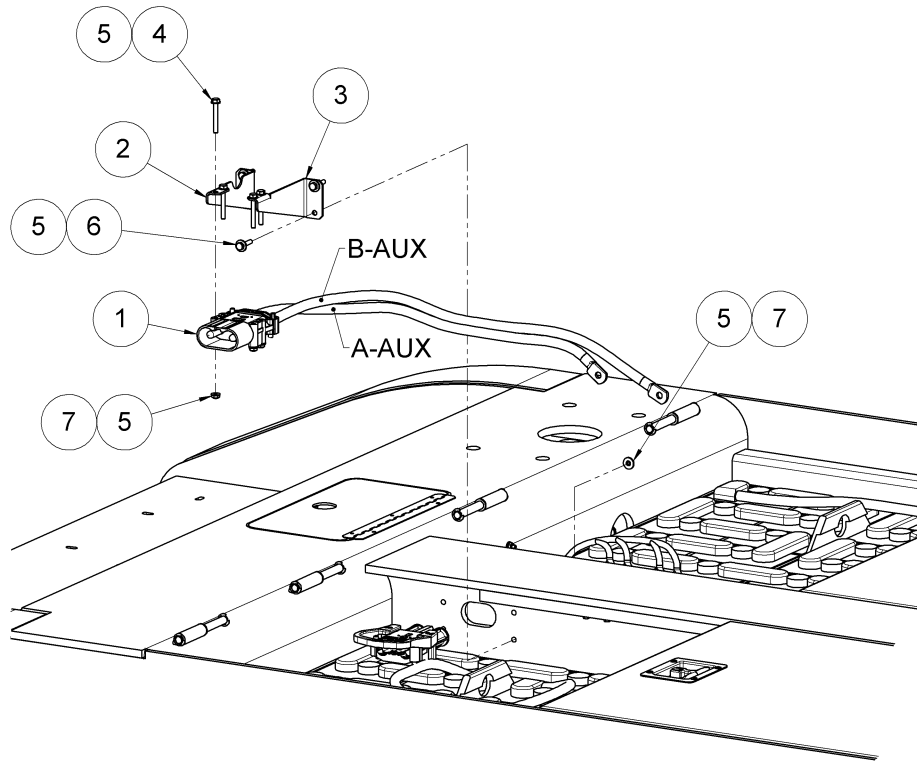

Item	Part Number	Qty.	Description
1	A-ES12-0447	1	EURO/DIN BATTERY CONNECTOR KIT
2	EX16-02-007-SA	1	EURO CONN BRKT, FRONT, DUAL BATTERY
3	EX16-02-008-SA	1	EURO CONN BRKT, REAR, DUAL BATTERY
4	NPN	4	HCS, 1/4-20 UNC X 2
5	NPN	16	FLAT WASHER, 1/4
6	NPN	4	HCS, 1/4-20 UNC X 1
7	NPN	8	LOCK NUT, 1/4-20 UNC

Dual Battery Option - eTT16 only

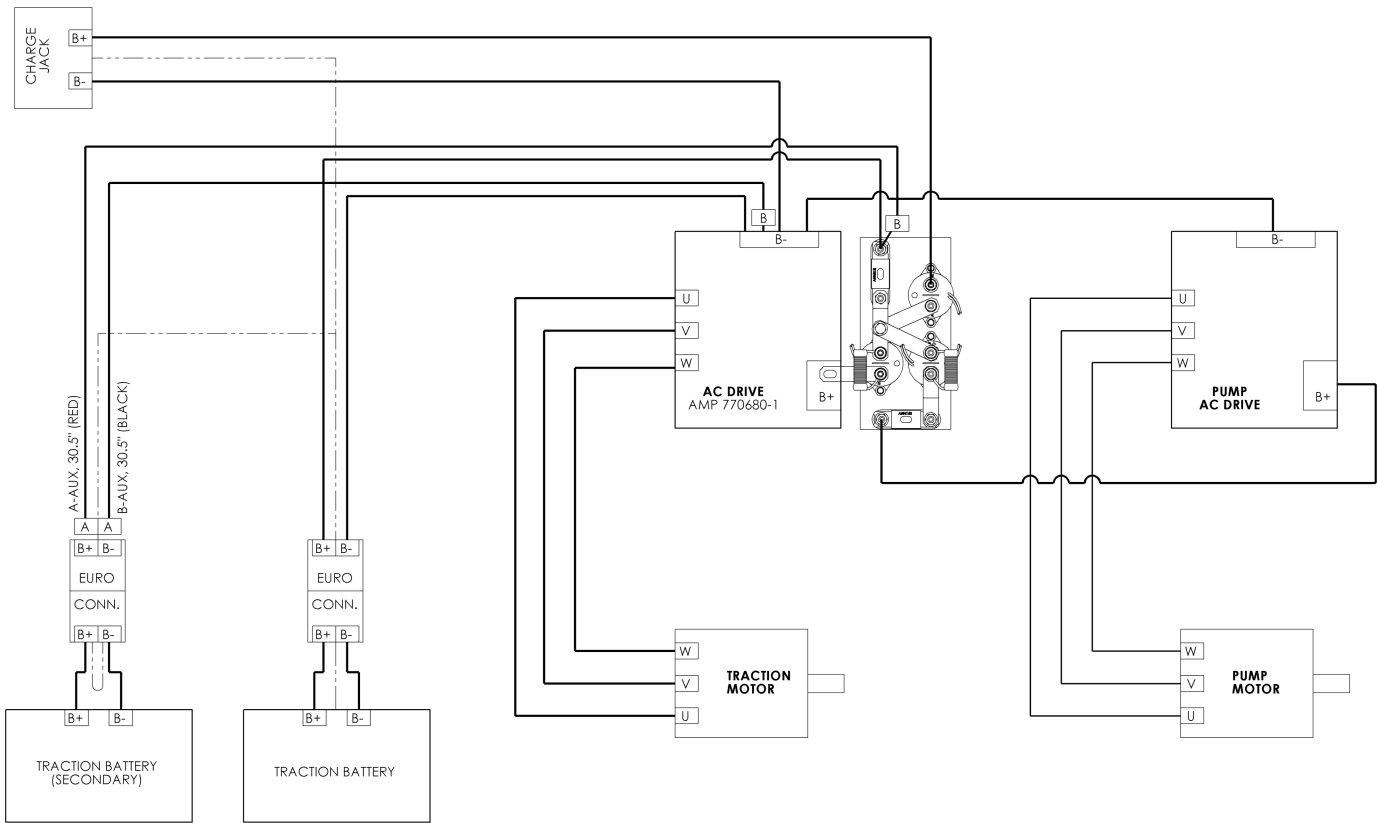

ITEM	WIRE				END A		END B	
	GAGE	COLOR	P/N	LENGTH	P/N	TYPE	P/N	TYPE
A-AUX	2/0	RED	A-ES12-0498	30.5"	A-ES12-0447	EURO	A-ES12-0497	STRAIGHT
B-AUX	2/0	BLACK	A-ES12-0499	31.5"	A-ES12-0447	EURO	A-ES12-0497	STRAIGHT

Cab Heater Schematic- eTT8/eTT12

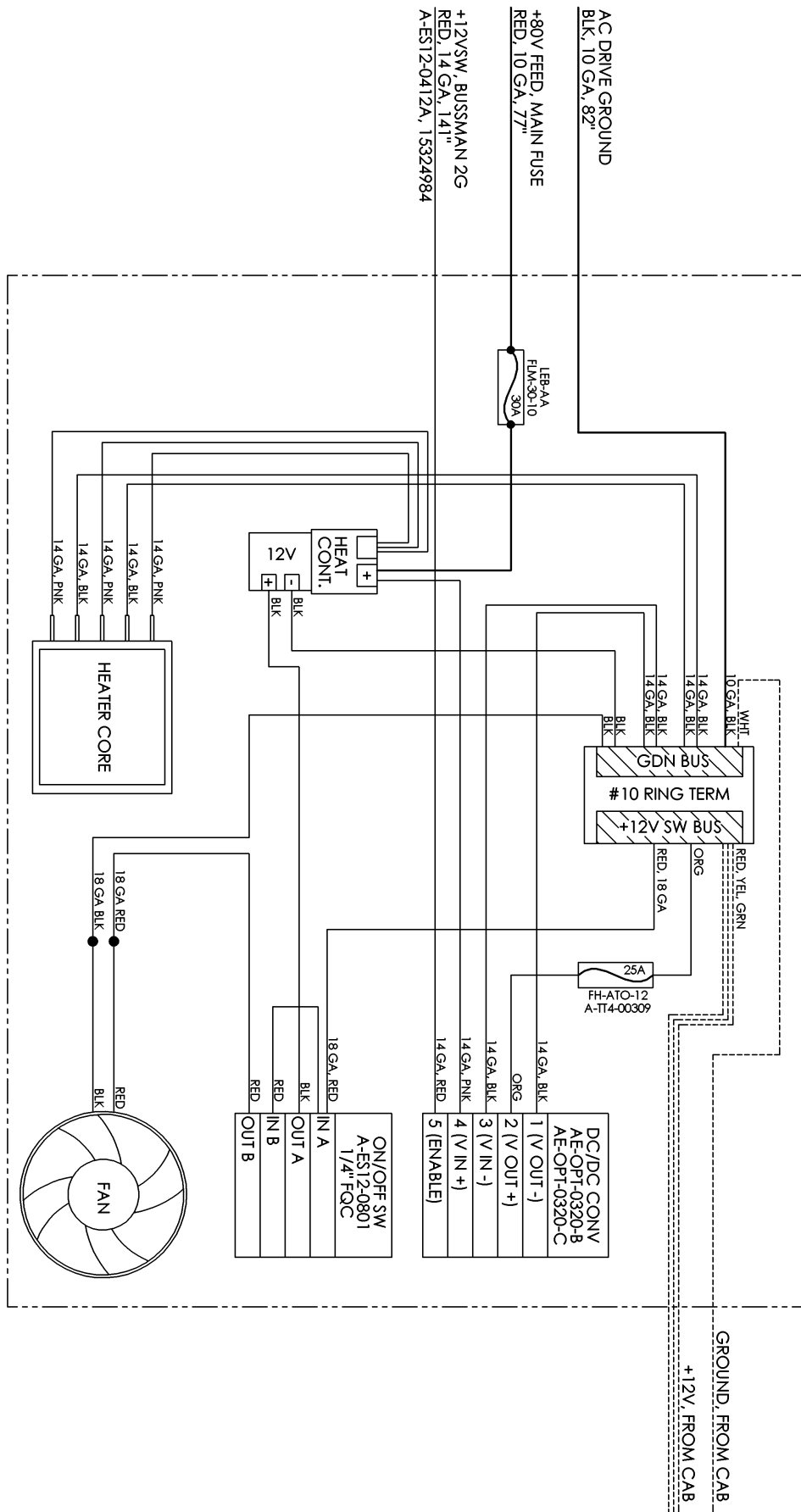

GROUND, FROM CAB
+12V, FROM CAB

Cab Heater - eTT8/eTT12

Item	Part Number	Qty.	Description
1	A-ES12-0210	1	HEATER MODULE WELDMENT
2	A-ES12-0211	1	HEATER MODULE FRONT COVER
3	A-ES12-0212	1	HEATER MODULE FAN BRACKET
4	AE-OPT-0320-B	1	DC/DC CONVERTER
5	A-MTT5-0235	1	FAN, Ø5.2
6	AE-OPT-0300-B	1	HEATER CORE
7	A-MTT5-0236	2	ADJUSTABLE LOUVER
8	A-ES12-0415-1	1	CONTACTOR, 12V
9	A-TT4-00300	1	TERMINAL BLOCK, BUS BAR
10	A-ES12-0801	1	ROCKER SWITCH, ON-OFF
11	AE-OPT-0320-E	3	GROMMET, HIGH TEMP, Ø.375 X .125 THK
12	AE-OPT-0320-D	2	SHOULDER SCREW, 3/8 SHOULDER X .25 X 5/16-18 UNC
13	NPN	2	LOCK NUT, 5/16-18 UNC
14	NPN	2	FLAT WASHER, 5/16
16	NPN	11	FLAT WASHER, 1/4
17	NPN	4	LOCK NUT, 1/4-20 UNC
18	NPN	11	HCS, 1/4-20 UNC X 1
19	NPN	19	LOCK NUT, #10-32 UNF
20	NPN	21	FLAT WASHER, #10
21	NPN	9	HCS, #10-32 UNF X 1
22	NPN	7	RIVNUT, 1/4-20

PVC Decking

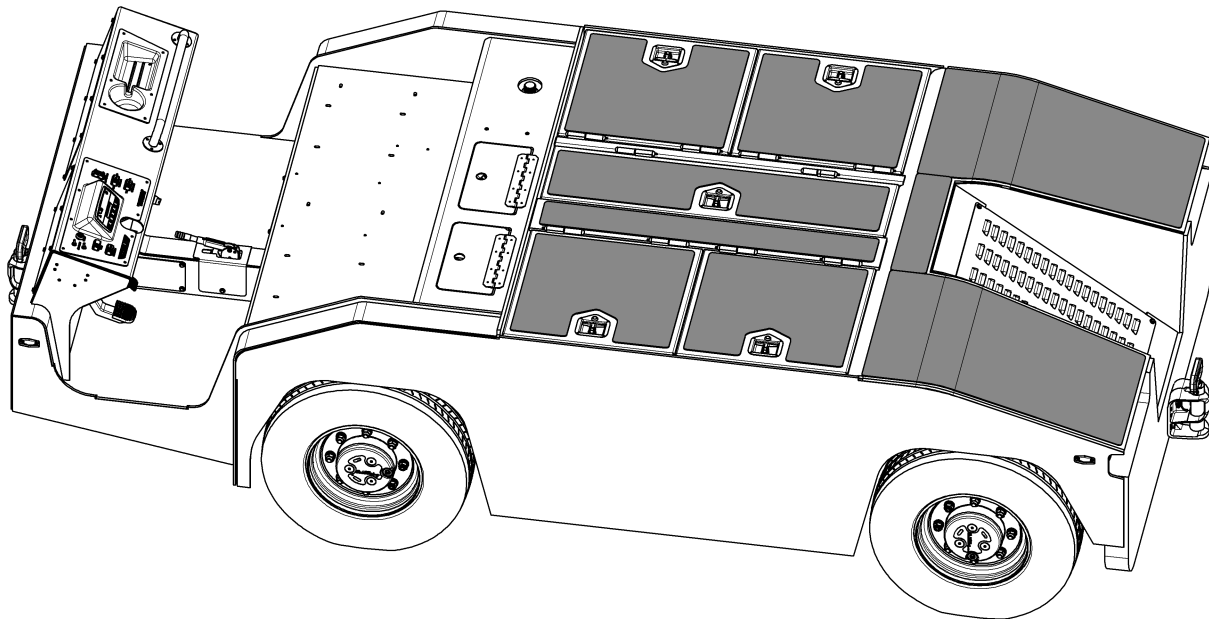
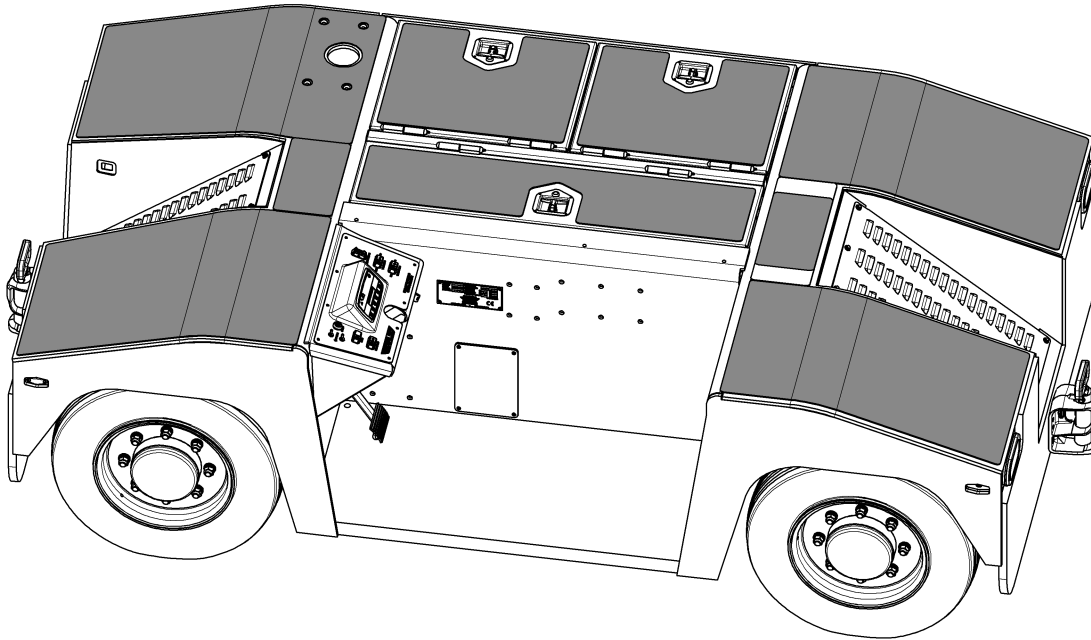

Item	Part Number	Qty.	Description
1	AE-OPT-ETT8-0115	1	PVC DECKING KIT (9 PCS)
2	AE-OPT-ETT12-0115	1	PVC DECKING KIT (9 PCS)
3	AE-OPT-ETT16-0115	1	PVC DECKING KIT (9 PCS)

PVC Decking

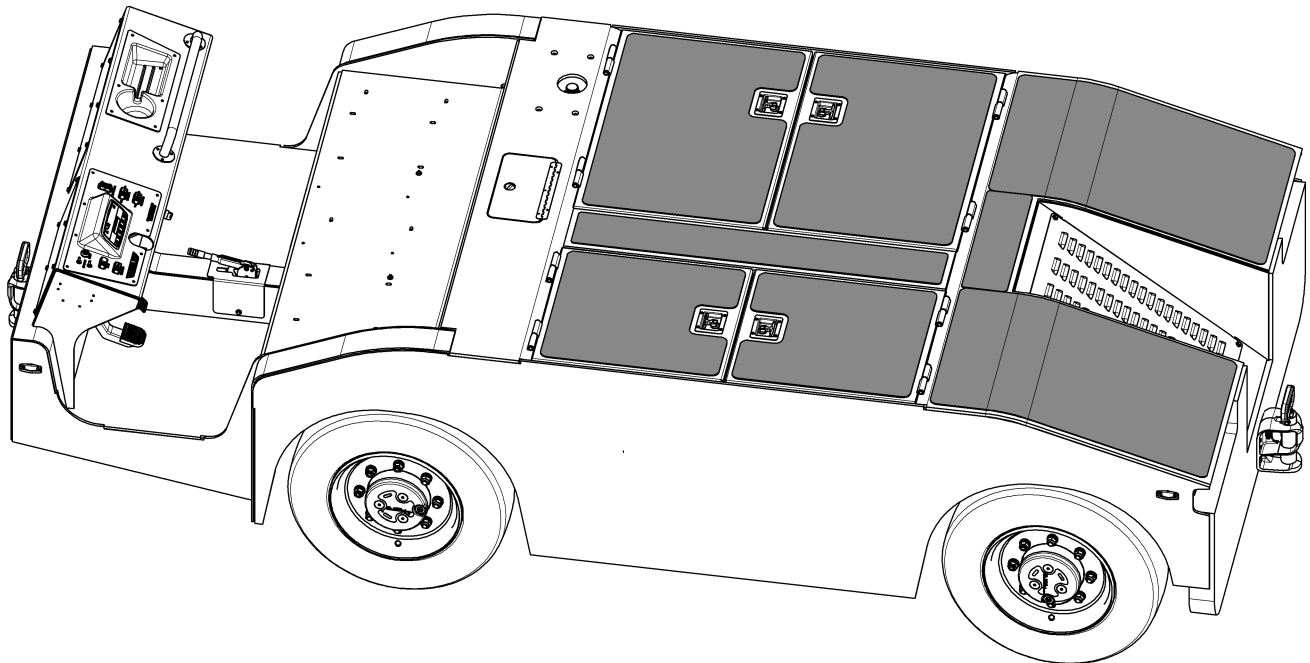
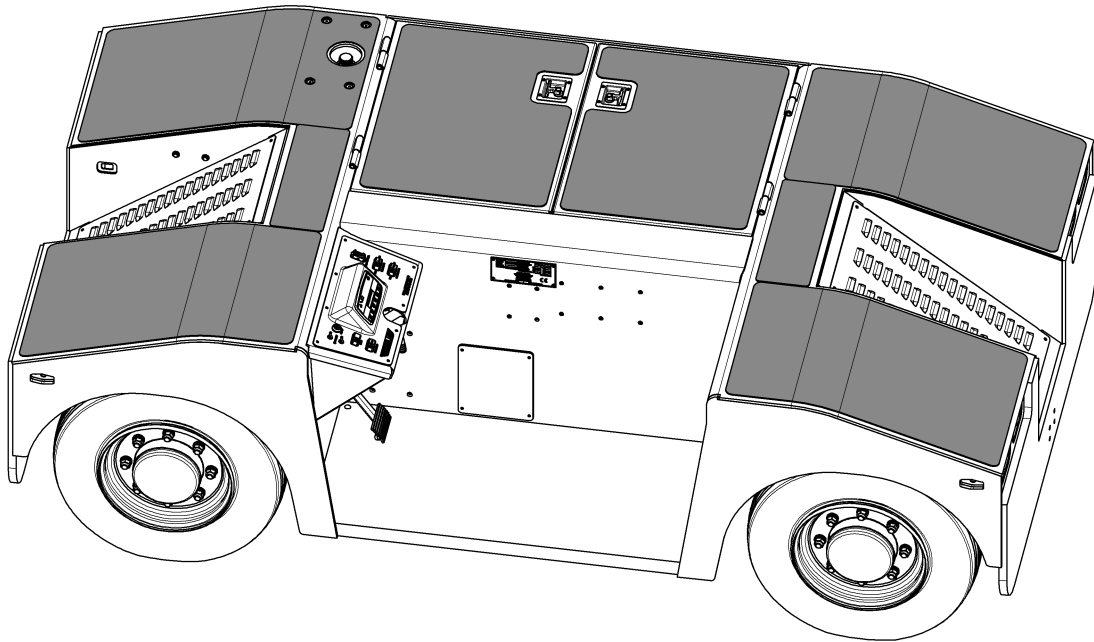

Item	Part Number	Qty.	Description
1	OPT-ET08-002-A	1	PVC DECKING KIT (8 PCS)
2	OPT-ET12-001-A	1	PVC DECKING KIT (8 PCS)
3	OPT-ET16-004-A	1	PVC DECKING KIT (8 PCS)

Revision Log

Rev	Date	Description	Appr.
A	25-Feb-2014	Original release for production	PRB
B	30-Apr-2014	Corrected cab heater illustrations and schematic.	SEB
C	15-May-2015	Added information for Rev G tractors.	DCM
D	7-Jan-2016	Corrected contactor part number.	DCM
E	6-Jun-2016	Changed eXL16 model name to eTT16	TFP

Table of Contents

Section 10 - Specifications	
Description	Page
Full Specifications	10-2
Fluids and Filters	10-4
Tractor Drawing	10-5
Revision Log	10-6

Full Specifications

Chassis System		
Length (Not Including Hitches)	130 inches	3302 mm
Chassis Width	71.9 inches	1826 mm
Chassis Height	43.3 inches	1100 mm
Height at Seat Back	45.6 inches	1157 mm
Step-in Height	11 inches	279 mm
Ground Clearance	9 inches	229 mm
Vehicle Weights		
Gross Vehicle Weight	14,200 lbs.	6,441 kg
Weight Distribution	50% Front / 50% Rear	
Drive Motor		
Model	Kollmorgen TSP 180/6-200	
Type	AC Induction	
Power	18.4 kW - S2 60 min	
Environmental Rating	IP20	
Drive Inverter		
Model	Kollmorgen ACS8025-550	
Power	550 A - 2 min	
Power	220 A - S2 60 min	
Environmental Rating	IP54	
Nominal Voltage	80V DC	
Cooling	Active - Finned Heatsink	
Pump Motor		
Model	Kollmorgen TSP 112/4-90-12	
Type	AC Induction	
Power	7.7 kW - S2 60 min	
Environmental Rating	IP20	
Pump Inverter		
Model	Kollmorgen ACS8010-220	
Power	220 A - 2 min	
Power	100 A - S2 60 min	
Environmental Rating	IP54	
Nominal Voltage	80V DC	
Cooling	Passive - Flat Heatsink	
Transfer Case		
Gear Ratio Low	4.286	
Gear Ratio High	1.359	
Shift Pressure (Maximum)	435 psi	30 bar

Full Specifications

Axles		
Wheelbase	90 inches	2286 mm
Track Width	62.6 inches	1591 mm
Inside Tire Steering Angle	35°	
Center Differential Ratio	2.909	
Planetary Ratio	6.000	
Overall Ratio	17.454	
Maximum Brake Pressure	638 psi	44 bar
Service Brakes	Wet Immersed Disc, Front and Rear	
Parking Brakes	Dry Disc, Located on Front Input Yoke	
Input Flange	1410 Yoke (Rear) / 1410 Flange (Front)	
Tires		
Tire Size	9.50R16.5	
Tire Capacity Rating	Load Range E	
Tire Inflation Pressure	75 psi	517 kPa
Electrical		
System Voltage	80 Volt Floating Ground	
Lighting Voltage	12 Volt Floating Ground	
12V Converter Rating	30A Intermittent / 25A Continuous	
Battery Specification		
Battery Designation	40-125-11	
Nominal Voltage	80V DC	
Capacity	625 Ahr	
Length	50.6 inches	1285 mm
Width	21.8 inches	554 mm
Height (At Lifting Ears)	31.1 inches	790 mm
Performance		
Drawbar Pull Rating	12,000 lbf	53.4 kN
Top Speed (Tow Gear)	5.0 mph	8.0 kph
Top Speed (High Gear)	12.0 mph	19.3 kph
Outside Turning Radius	140 inches	3556 mm
Approach Angle Without Hitch	35.2°	
Departure Angle Without Hitch	32.4°	
Breakover Angle	25.4°	
Fluid Specifications		
Hydraulic Steering and Braking	Castrol Dual Range HV 32	
Axle and Transfer Case Oil	Castrol Trans-C SAE 50	

Fluids and Filters

Fluid Specifications

Fluid	Recommendation	Requirement	Volume (approx.)
Hydraulic Fluid	Castrol Dual Range HV 32	N/A	10.3 gallons / 47 liters
Transfer Case Oil	Castrol Trans-C SAE 50	API GL4	4.3 quarts / 4.0 liters
Front Axle Gear Oil	Castrol Trans-C SAE 50	API GL4	12.3 quarts / 11.6 liters
Rear Axle Gear Oil	Castrol Trans-C SAE 50	API GL4	12.3 quarts / 11.6 liters

Filter Specifications

Filter	Part Number
Hydraulic Filter	A-ES12-0485

Tractor Drawing

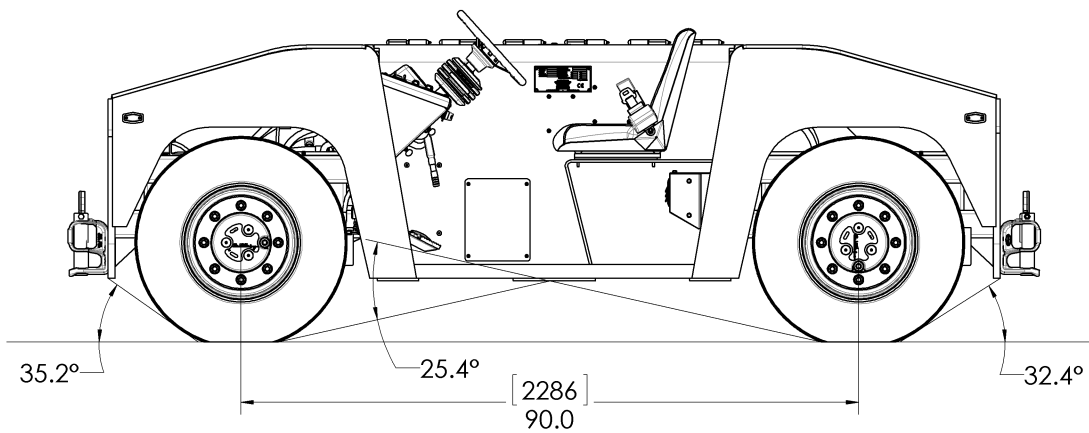
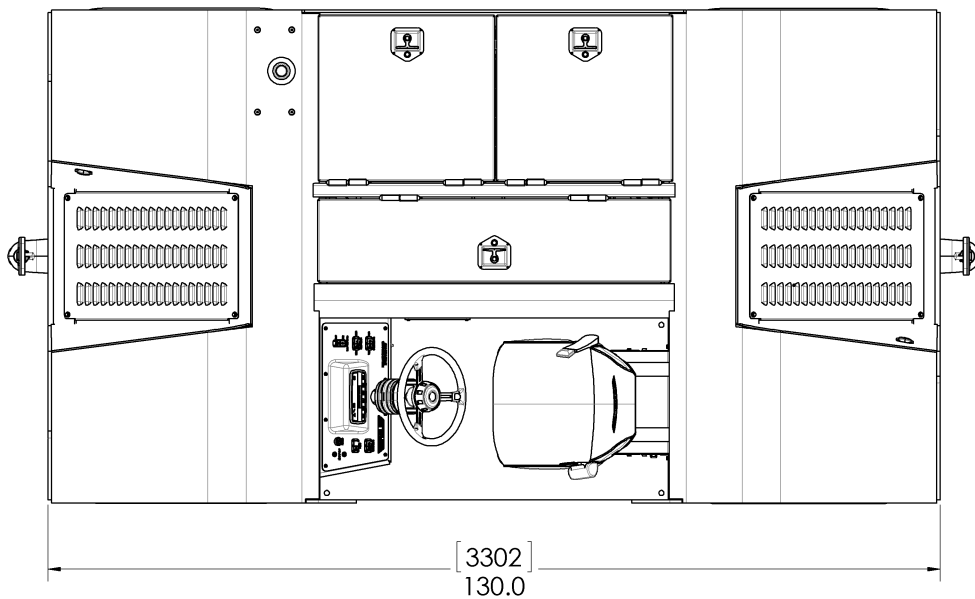
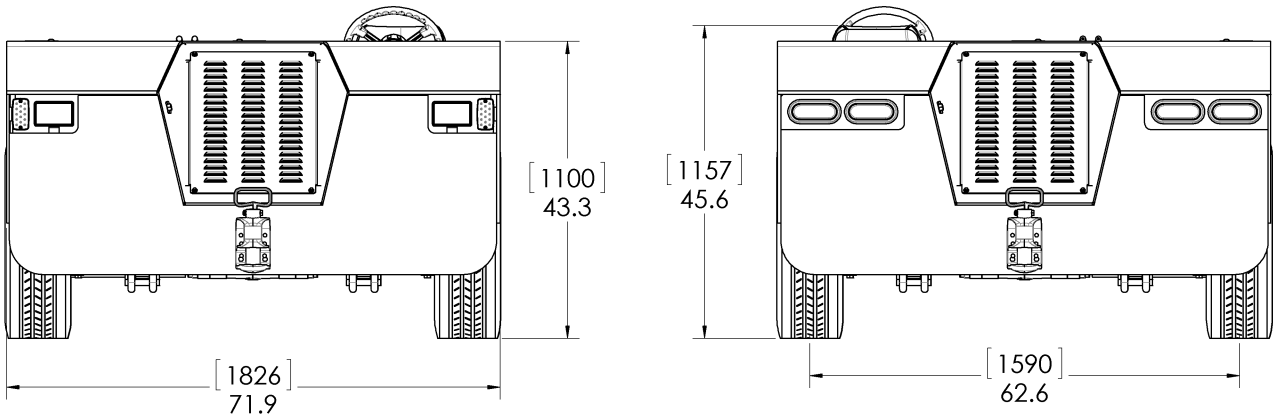

Optional equipment shown; customer tractor may vary.

Revision Log

Rev	Date	Description	Appr.
A	17-Apr-2014	Original release for production.	PRB
B	26-May-2015	Corrected axle fill volume.	DCM

Section 11 - Preventive Maintenance	
Description	Page
Preventive Maintenance Schedule	11-2
Hydraulic Filter and Fluid	11-3
Axles	11-4
Transfer Case	11-5
Grease Points	11-6
Hitch Wear	11-7
Revision Log	11-8

Preventive Maintenance

Preventive Maintenance Item	Daily	Weekly	First 50 hours	First 150 hours	250 hours or monthly †	500 hours	1500 hours or annually †
Perform daily pre-operation checklist (see Operations Manual)	X						
Check hydraulic fluid level and top off if necessary		X					
Verify tire pressure and add air as necessary		X					
Perform a battery equalization charge then water		X					
Re-torque front and rear axle U-bolts			X				
Drain and replace axle oil; center and planetaries (first time only)				X			
Drain and replace transfer case oil (first time only)				X			
Check and log specific gravity of all battery cells (fully charged)					X		
Check axle oil level; center and planetaries						X	
Clean axle oil breathers						X	
Grease upper and lower kingpin grease fittings on axles						X	
Check transfer case oil level						X	
Clean transfer case oil breather						X	
Grease driveshaft U-joints and slip shafts						X	
Inspect wheel lug nuts and tighten if necessary						X	
Check all battery cable connections for tightness and corrosion							X
Drain and replace axle oil; center and planetaries							X
Clean axle magnetic drain plugs							X
Drain and replace transfer case oil							X
Clean transfer case magnetic drain plug							X
Drain hydraulic fluid from tank and replace							X
Remove and clean hydraulic magnetic drain plug							X
Replace hydraulic filter							X
Re-torque front axle U-bolts if they show signs of loosening							X
Re-torque driveshaft U-joint straps and flange hardware							X
Check wet brake disc wear							X
Check front parking brake disc and pads and replace if necessary							X
Inspect steering tie-rod ball ends for play and replace if necessary							X
Inspect steering tie-rod adjustment nuts and tighten if necessary							X
Inspect steering stops and re-set/tighten if necessary							X
Inspect steering sensor potentiometers							X
Inspect all hydraulic tubes and hoses for wear/damage and leaks							X
Inspect hitch pins for wear and replace if beyond specifications							X
Inspect motor / transfer case mount isolators and replace if necessary							X
Check steering accumulator pre-charge pressure (key-on hours)							X
Check brake accumulator pre-charge pressure (key-on hours)							X

Any items found to be deficient during the preventive maintenance review should be repaired or replaced. All fluids found low should be topped off. All hours are traction hours unless otherwise specified.

† Whichever time period is shorter.

Hydraulic Fluid and Filter

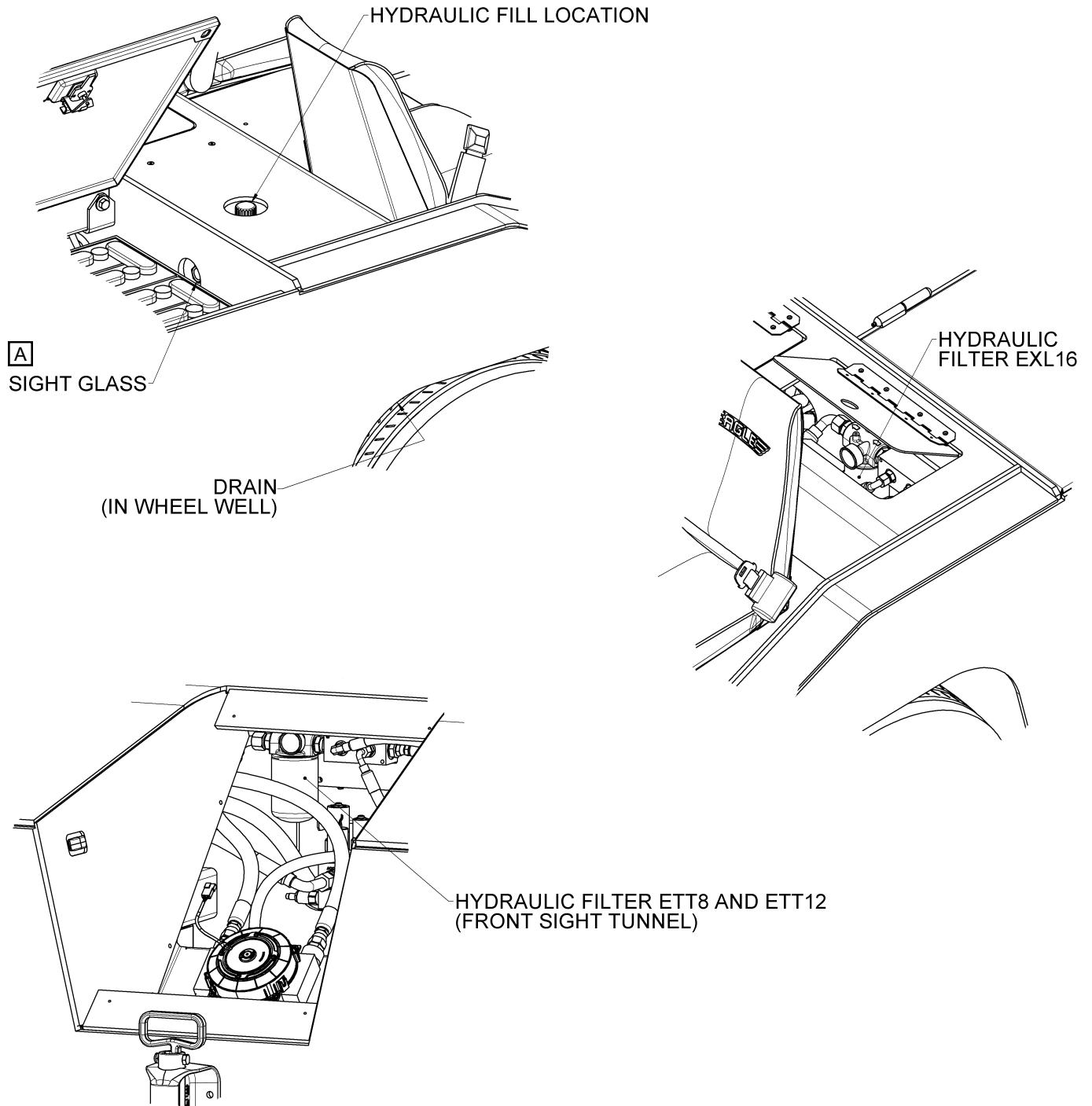

A Warning: correct hydraulic level is to the center of the sight glass with the steering system charged. Filling past the sight glass can result in overflow due to stored volume in the accumulators.

Fluid	Recommendation	System Volume (approx.)		
		eTT8	eTT12	eTT16
Hydraulic	Castrol Dual Range HV 32	8.8 gallons / 33 liters	10.3 gallons / 39 liters	12.3 gallons / 47 liters

Filter	Part Number
Hydraulic	A-ES12-0485

Axles

Tractors eTT12 and eTT16:

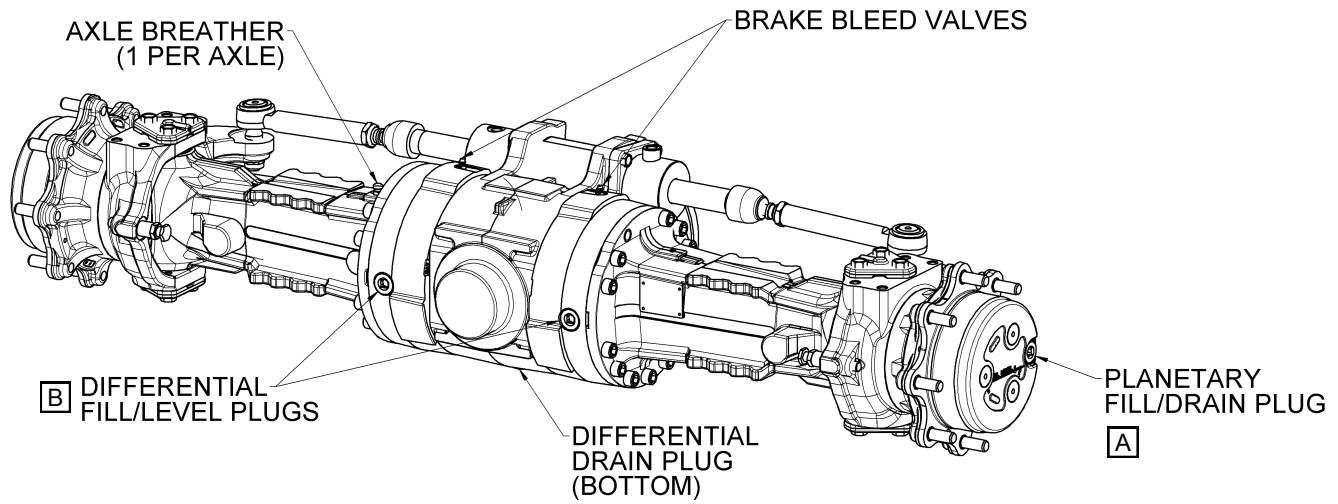

Tractors eTT8:

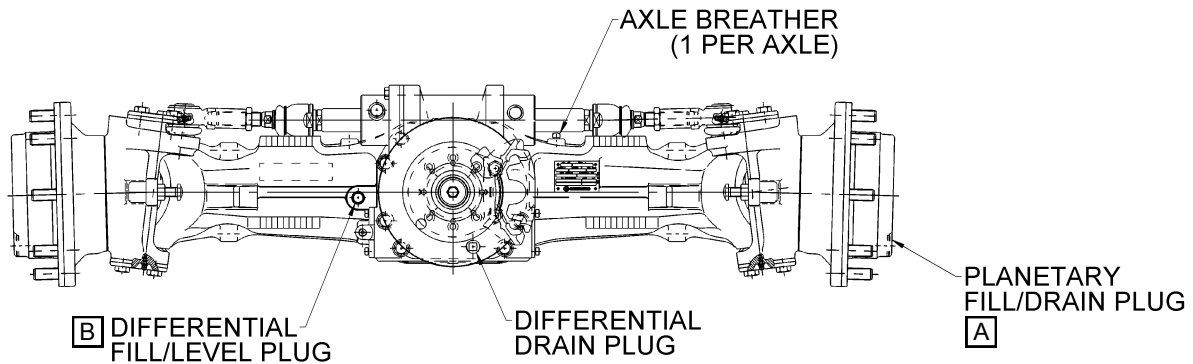

A Fill planetary ends to the bottom of the fill hole with the axle end rotated so that the arrow on the casting is horizontal. Axle must also be horizontal.

B Fill to the bottom of the fill hole with the axle horizontal.

	Fluid	Recommendation	Requirement	Center Diff Volume (approx.)	Planetary End Volume (approx.) Each
eTT8	Axle Oil	Castrol Trans-C SAE 50	API GL4	4.8 quarts /4.5 liters	.7 quarts / .7 liters
eTT12/eTT16				10.6 quarts /10 liters	.8 quarts / .8 liters

Transfer Case

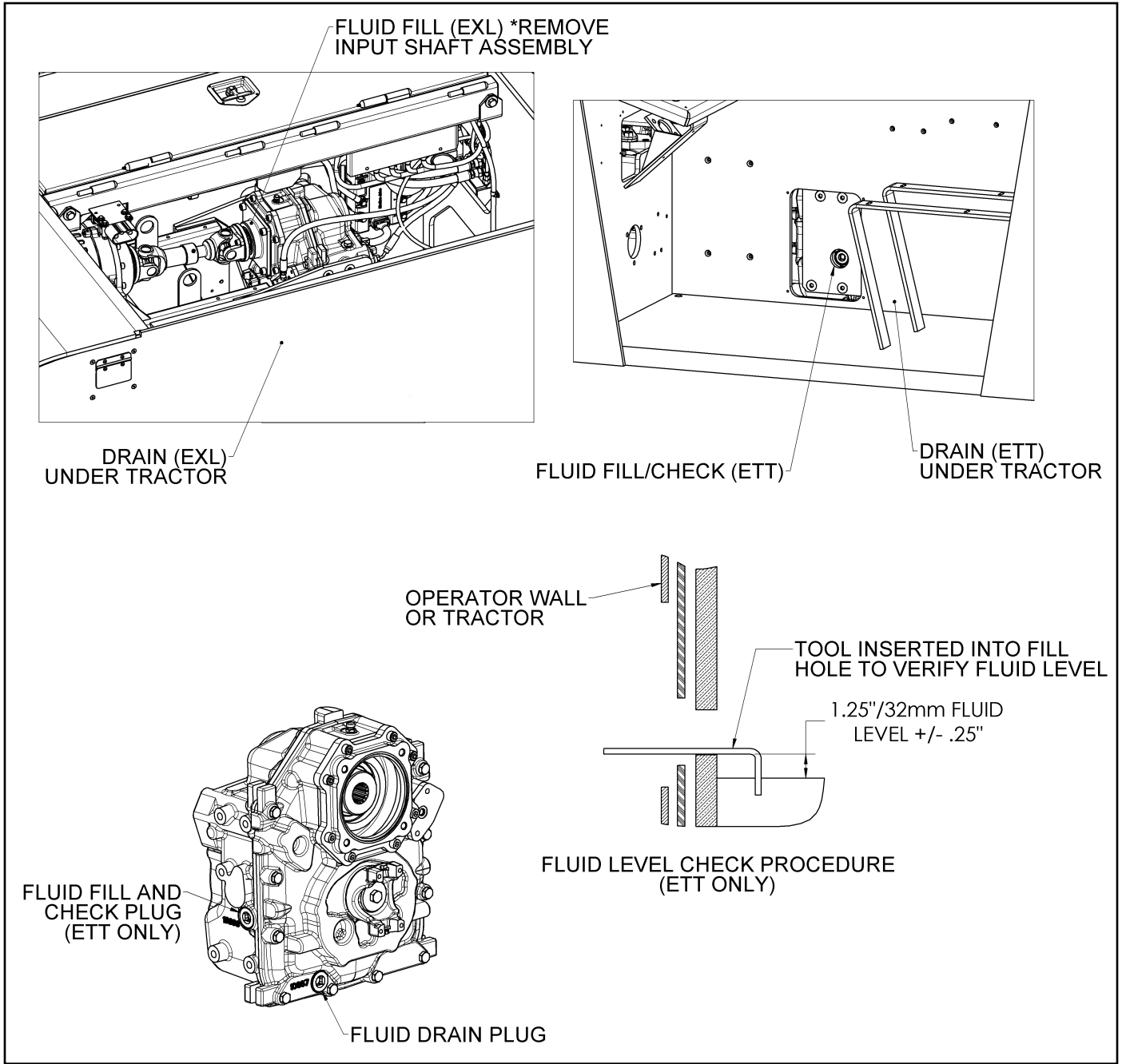

Fluid	Recommendation	Requirement	Volume (approx.)
Gearbox Oil	Castrol Trans-C SAE 50	API GL4	4.3 quarts / 4.0 liters

Grease Points

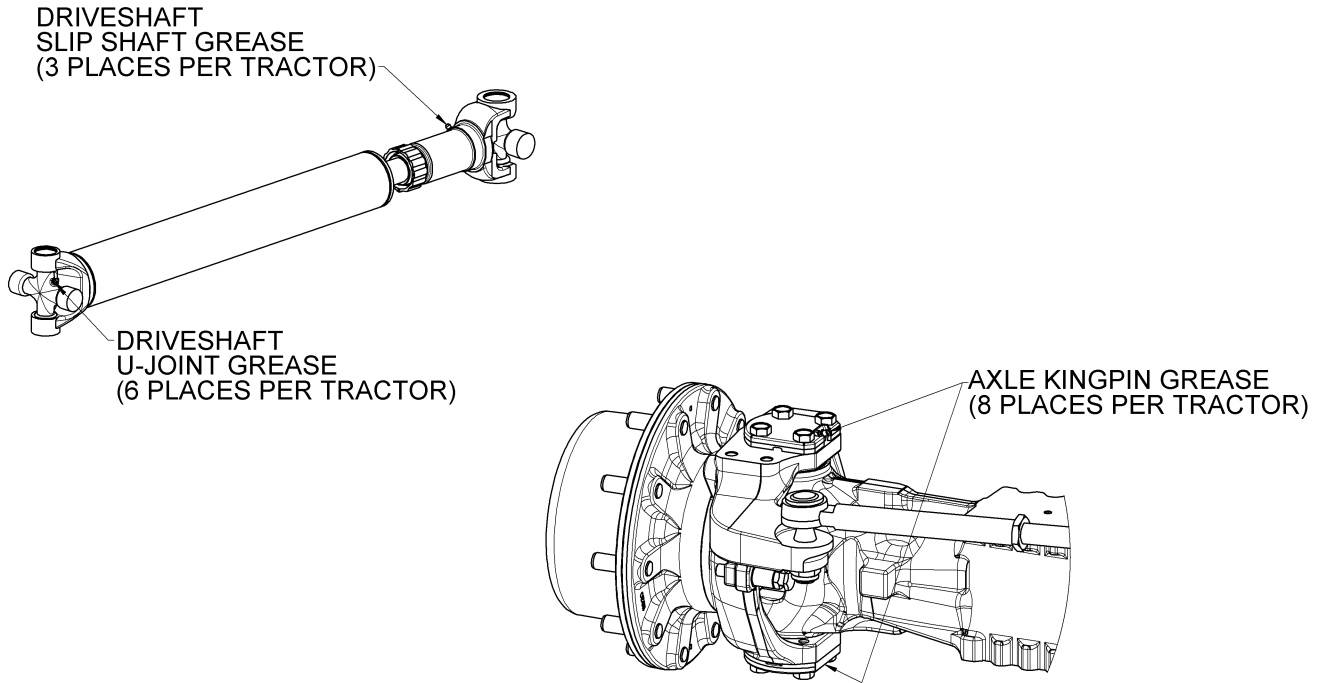

Grease points should have grease added per the Preventive Maintenance Schedule. Grease should be added until old grease is visible being extruded from the joint.

Fluid	Spec
Multi Purpose Grease	NGLI 2

Hitch Wear

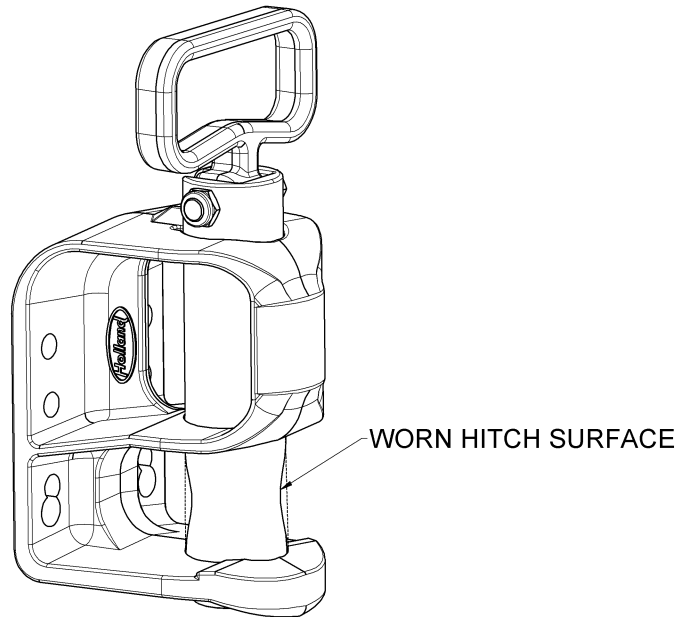

Hitch pins should be replaced if the pin surface wear exceeds .125" or 3mm from the original surface profile (on any height position).

Revision Log

Rev	Date	Description	Appr.
A	26-Feb-2014	Original release for production	PRB
B	15-May-2015	Corrected axle fluid quantities.	DCM
C	7-Oct-2015	Modified eXL-16 transfer case fluid fill location	PRB
D	6-Jun-2016	Changed eXL16 model name to eTT16	TFP

Table of Contents

Section 12 - Safe Handling	
Description	Page
Tie-Downs	12-2
Jack and Jack Stand Locations	12-3
Weight Distribution Without Battery	12-4
Flat Towing	12-5
Center of Gravity - eTT8	12-6
Center of Gravity - eTT12	12-7
Center of Gravity - eTT16	12-8
Lifting Provisions	12-9
Revision Log	12-10

Tie-Downs

Tractors eTT16:

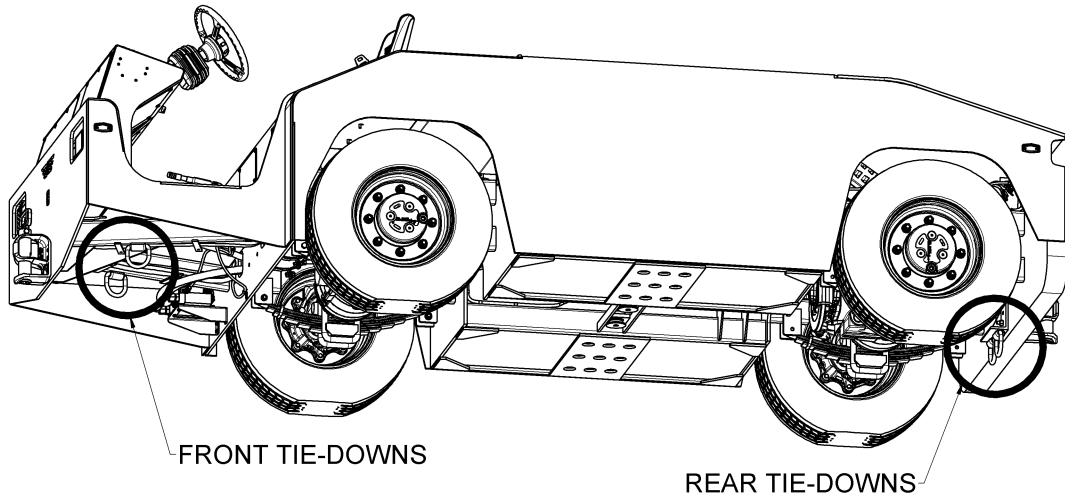

Tractors eTT8 and eTT12:

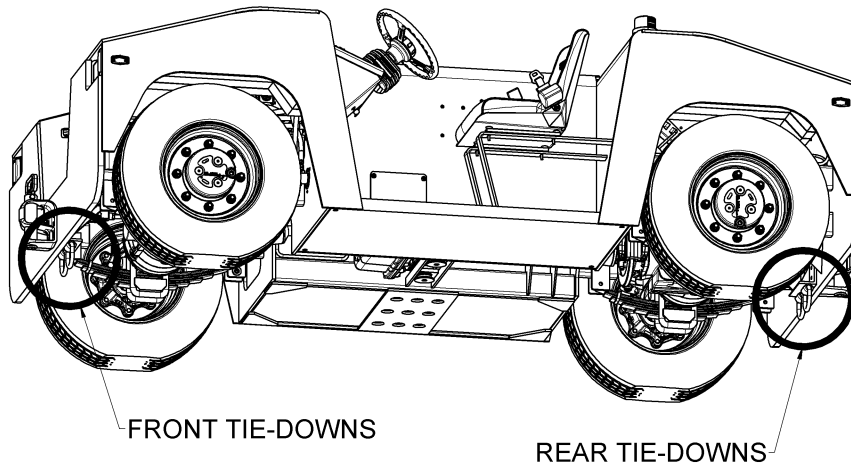

The eTT is equipped with four heavy duty tie-down rings located on the front and rear of the tractor. These tie-downs provide for safe ground transportation.

When securing the tractor, chains/straps should not make contact with the tractor in any area other than the tie-down rings. At no point should the hitches be used for securing the tractor.

Jacking and Jack-Stand Locations

Tractors eTT16:

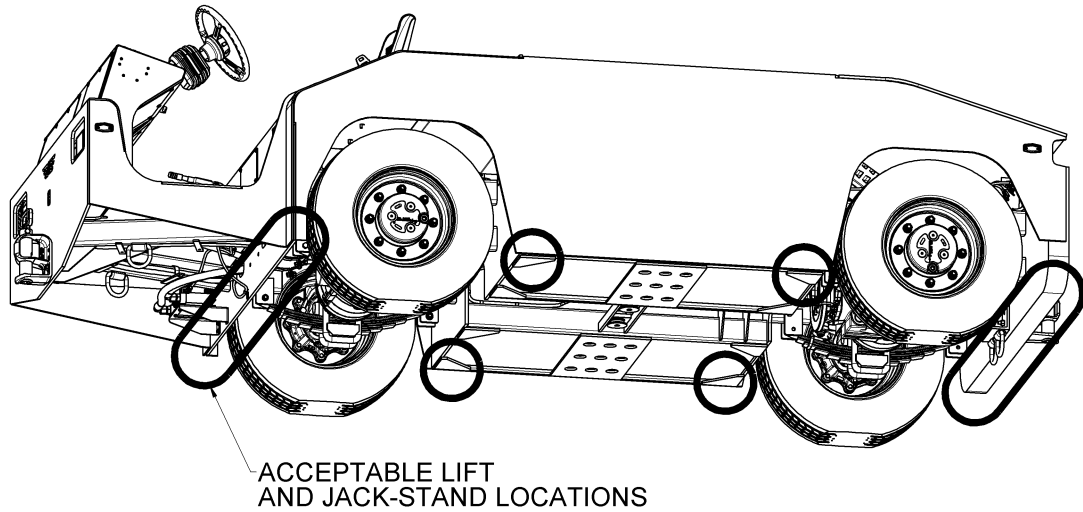

Tractors eTT8 and eTT12:

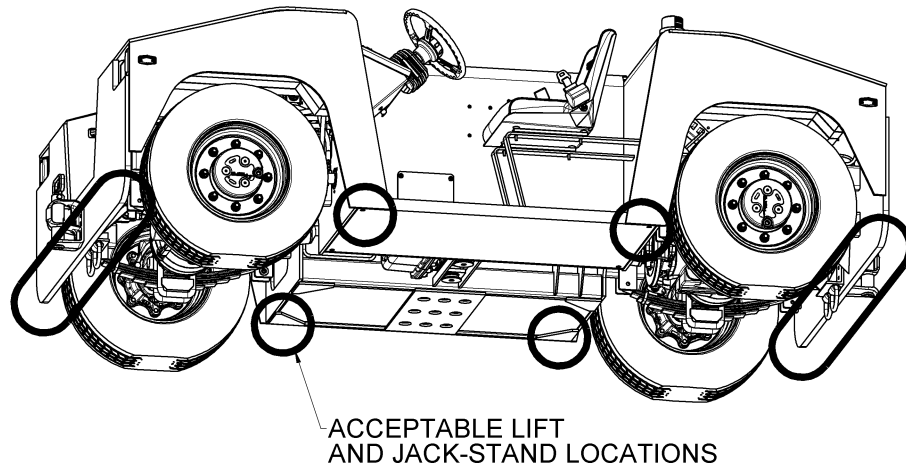

When lifting the eTT with jacks use the locations shown above for maximum safety.

Jacks and jack stands should be rated for 5 short tons or 5 metric tons minimum when using one located at each corner of the tractor.

Weight Distribution Without Battery

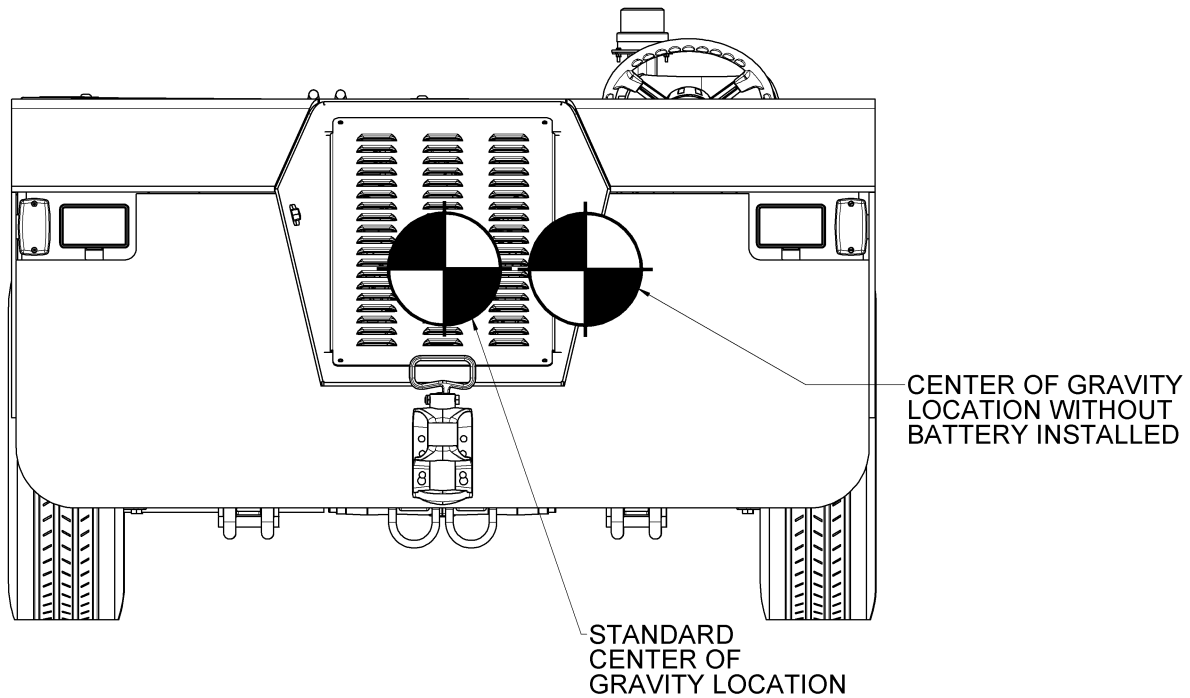

The battery or batteries of the eTT series tractor constitutes a large portion of the total tractor weight. Removal of the battery will result in a large shift in center of gravity location.

When transporting or handling a tractor without a battery installed, the new center of gravity needs to be taken into account. When lifting with a fork lift, always lift from the heavy side (non-battery side). When lifting with jacks, factor in the new center of gravity location.

Flat Towing

Should the eTT tractor be disabled, it can be flat towed for short distances without any modification as long as the following is observed:

- The maximum speed should never exceed 5 mph / 4.5 kph.
- The maximum distance should not exceed .5 mile / .8 kilometer.
- The tractor is turned off and the battery is disconnected.

During towing, the front axle may be steered with the steering wheel, but at a greatly increased effort. The rear axle will not be steerable and, if possible, should be centered before towing.

If necessary, the tractor can be towed with full steering by performing the following steps. Note that the maximum speed and distance requirements are still in effect.

- Turn the tractor off.
- Disconnect the shift valve electrical connectors (see section 6).
- Manually shift the transfer case to neutral by moving the shift lever to the center location. See the below diagram. A pair of channel lock pliers is sufficient for moving the lever.
- Turn the tractor back on.

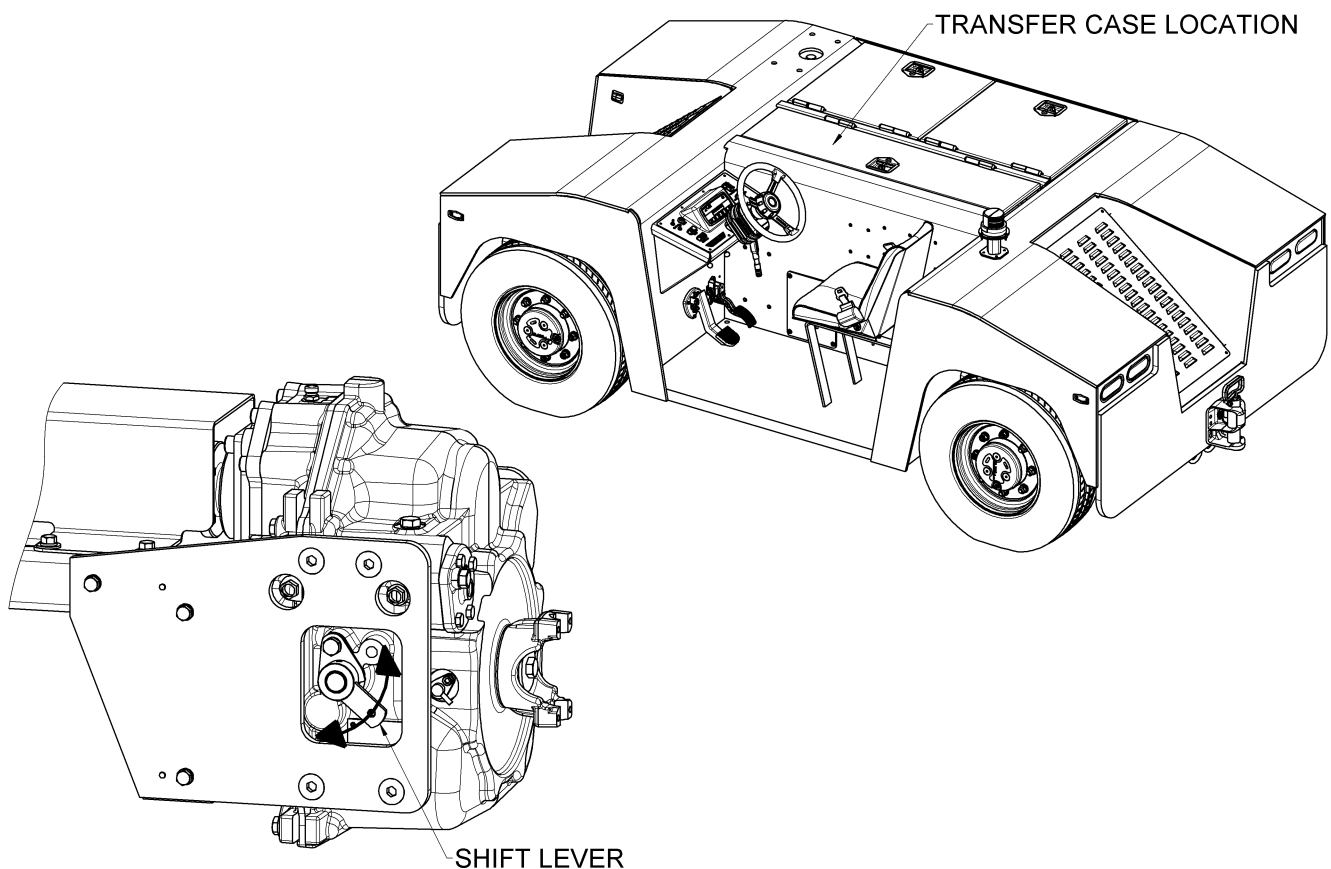

Center of Gravity - eTT8

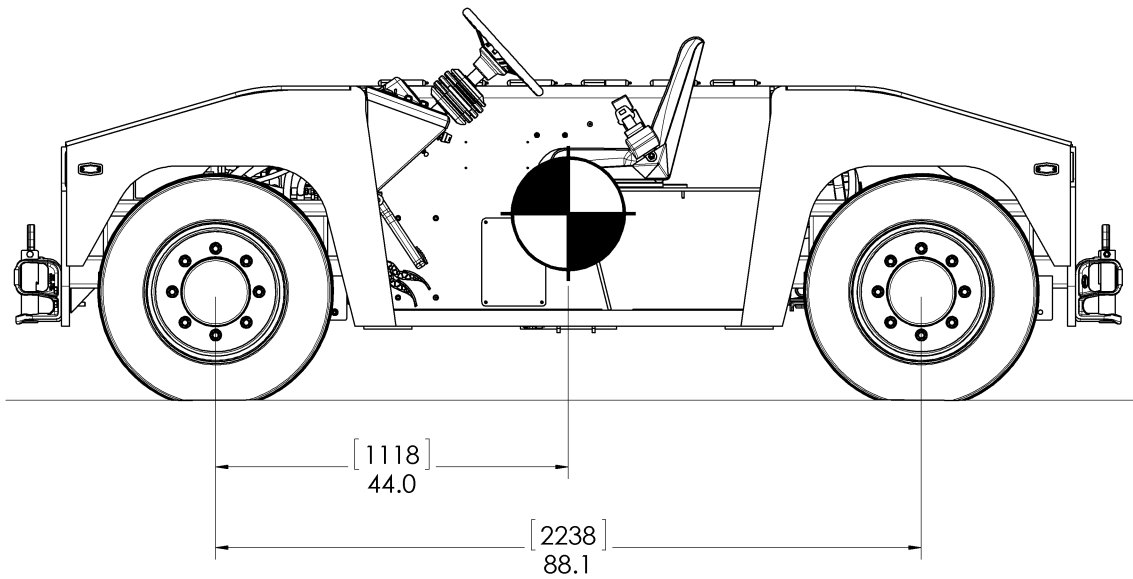
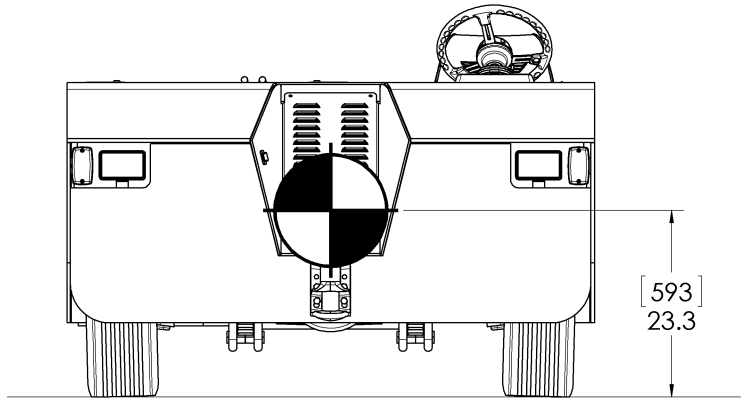

Center of Gravity - eTT12

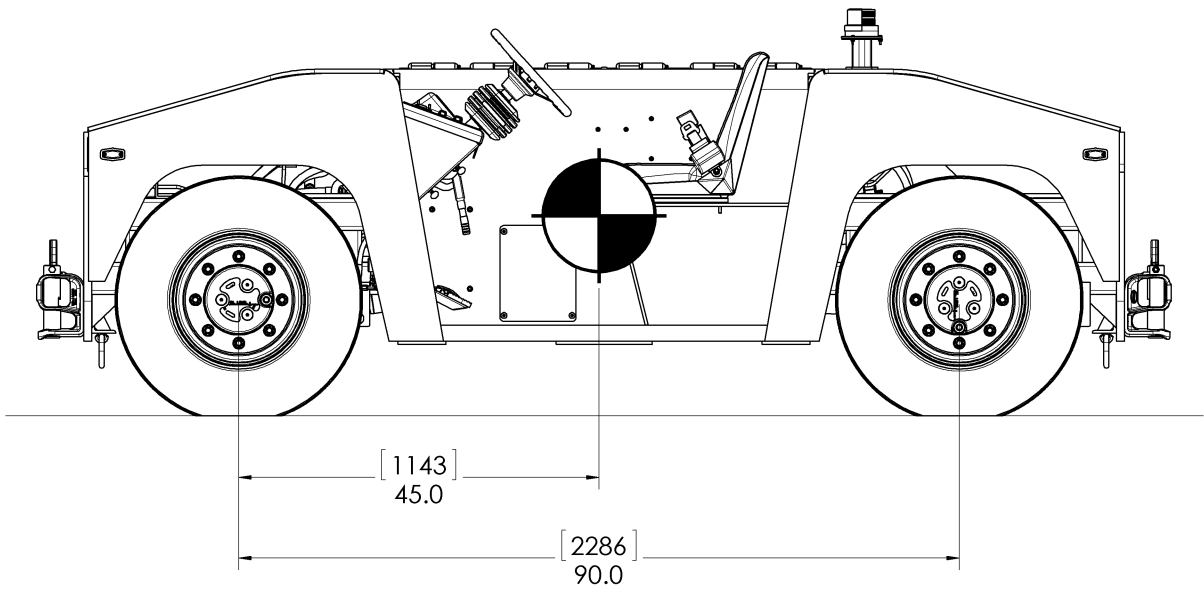
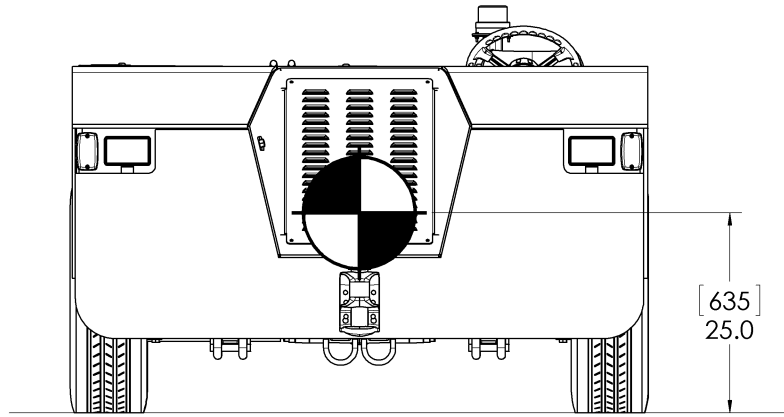

Center of Gravity - eTT16

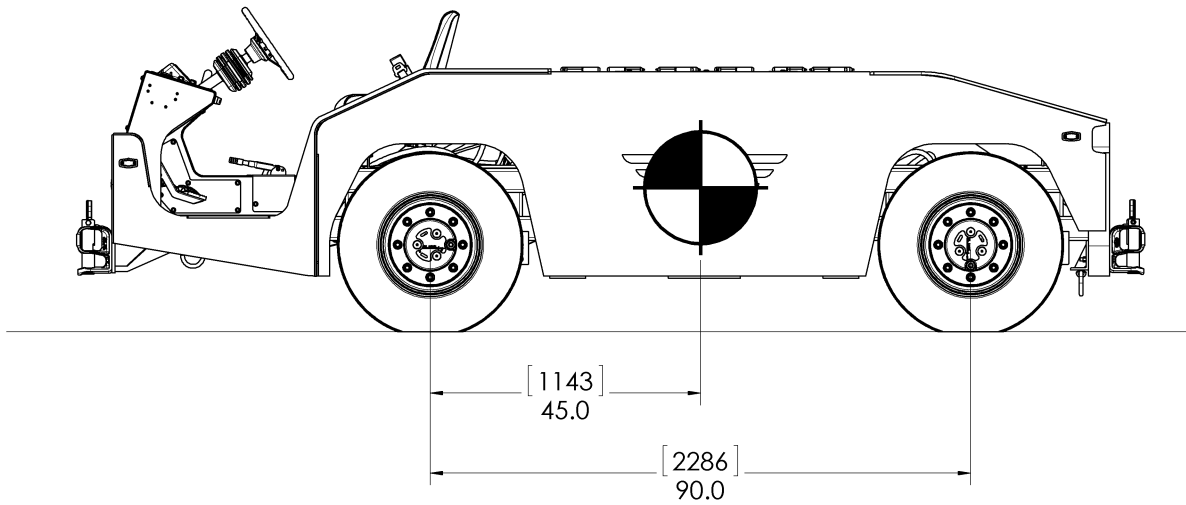
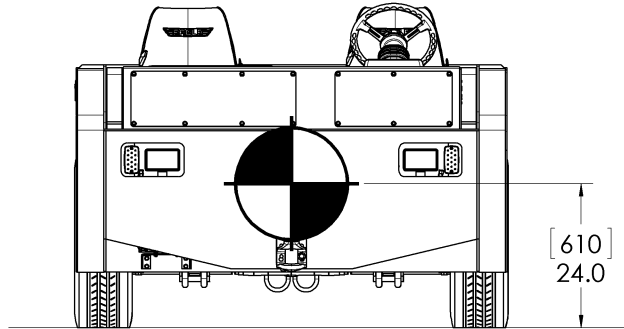

Lifting Provisions

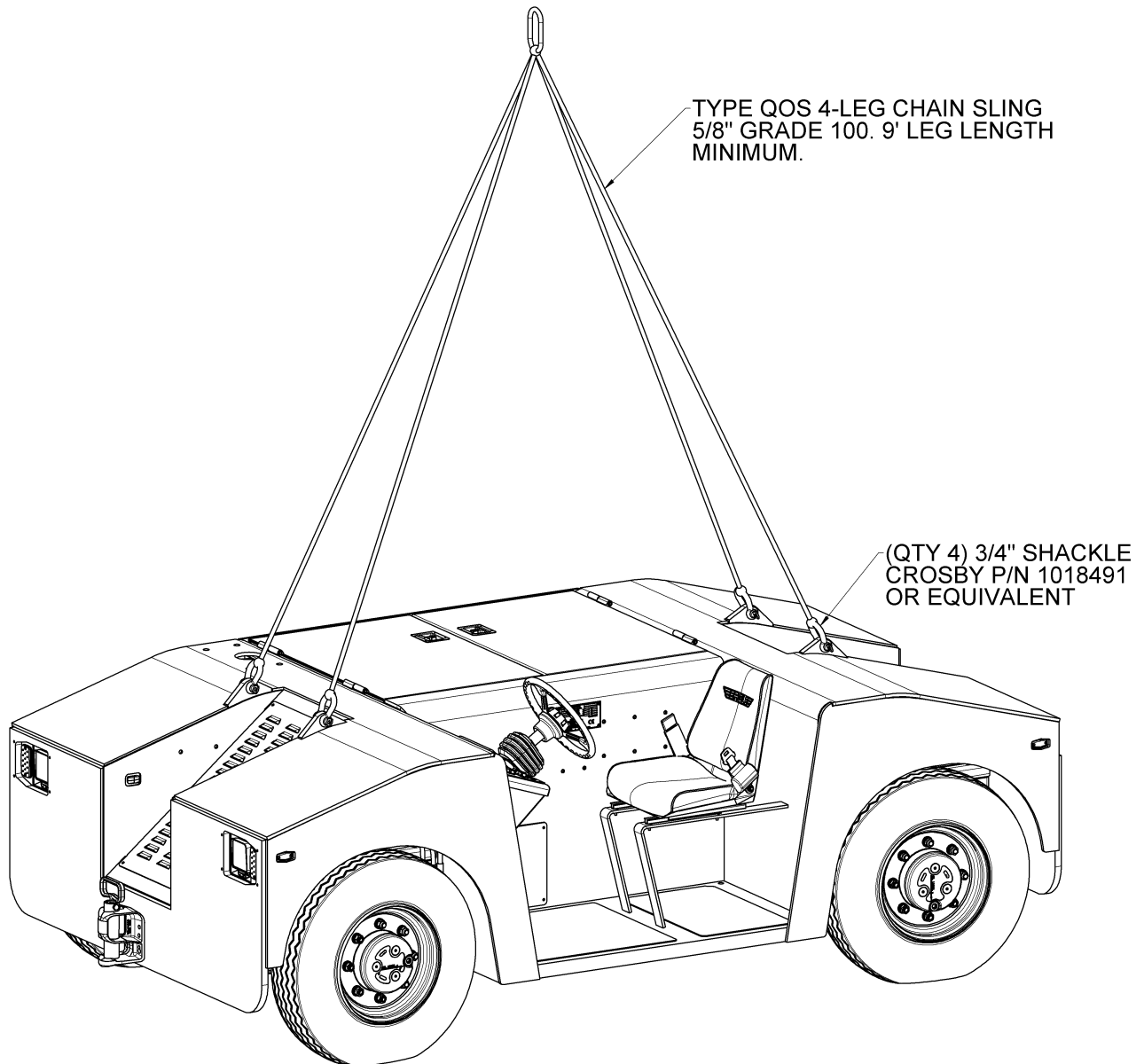

The eTT tractors as of Jan 2015 can be optionally equipped with lifting lugs integrated into the chassis. These lugs provide a safe mechanism for overhead lifting of the eTT tractor.

It is the responsibility of the customer to supply four 3/4" shackles (Crosby P/N 1018491 or equivalent) and a type QOS 4-leg 5/8" grade 100 chain sling with leg lengths no smaller than 9'. Using this equipment, the tractor can be safely lifted as shown.

Revision Log

Rev	Date	Description	Appr.
A	26-Feb-2014	Original release for production	PRB
B	12-Feb-2015	Added lifting provision information	PRB
C	6-Jun-2016	Changed eXL16 model name to eTT16	TFP

Section 13 - Troubleshooting	
Description	Page
OPT10 Diagnostic Usage	13-2
Error Code Troubleshooting	13-3
Operational Troubleshooting	13-12

OPT10 Diagnostic Usage

The OPT10 digital display is capable of displaying many tractor inputs and outputs. These are extremely helpful when trying to diagnose an issue with the tractor. This section will explain how to use the OPT10 to examine this diagnostic data.

The OPT10 display has several membrane switches located below the LCD panel that allow the operator or maintenance person to interface with the tractor. While seated on the eTT unit with the unit turned on, press **. The unit will prompt for a password, the default password is 5 5 5 5. Once the password has been entered, the display is in diagnostic mode. The up and down arrows can be used to select different diagnostic functions, and the right/left arrows can be used to go down or up menu hierarchies. See the overall menu hierarchy below.

As a quick illustration, entering the diagnostic menu and then selecting INPUT DIAGNOSTICS -> FRONT STEER COUNTS. The display will show the current front steer sensor value. Manually steering the wheel will allow you to see the value change based on the steering angle. Below is a map of the menus on the display showing what parameters are available to view.

The troubleshooting section of this manual will refer to verifying input/output functionality based on using the diagnostic tools on the OPT10.

Below is a map of the menu system and what variables can be monitored

1 INPUT DIAGNOSTICS	KEY SWITCH OPERATOR PRESENT SW PARKING BRAKE SW LOW GEAR SENSOR REVERSE SWITCH HIGH SHIFT SWITCH LOW SHIFT SWITCH HIGH GEAR SENSOR LOW PRESSURE SWITCH HI PRESSURE SWITCH HYDRAULIC OVERTEMP	INCH FORWARD SWITCH INCH REVERSE SWITCH FOOTBRAKE SWITCH BATTERY VOLTAGE REFERENCE COUNTS THROTTLE POT COUNTS FOOT PEDAL SWITCH FRONT STEER COUNTS REAR STEER COUNTS MOTOR SPEED SENSOR
2 OUTPUT DIAGNOSTICS	BRAKE LIGHT HIGH GEAR LIGHT LOW GEAR LIGHT MAIN CONTACTOR HYDRAULIC CONTACTOR	SHIFT LOW SOLENOID SHIFT HIGH SOLENOID TURN POSITIVE SOL TURN NEGATIVE SOL
3 TEMPERATURE	TRACT ACS TEMP TRACT MOTOR TEMP	PUMP ACS TEMP PUMP MOTOR TEMP
4 ERROR LOG	ERROR #	NUMBER OF OCCURENCES
5 STEER SETUP	FRONT CENTER CTS FRONT MAX LEFT CTS FRONT MAX RIGHT CTS REAR CENTER CTS	REAR MAX LEFT CTS REAR MAX RIGHT CTS STORE PARAMS
6 REGEN SETUP	NEUTRAL BRAKE LOW NEUTRAL BRAKE HIGH PEDAL BRAKE LOW	PEDAL BRAKE HIGH STORE PARAMS

To exit diagnostic mode, press the left button several times, or cycle tractor power.

Error Code Troubleshooting

Should the eTT tractor encounter a system error, the OPT10 display may display one or more error codes. These codes are intended to direct technicians to the most likely cause of the error. Making use of both the error codes as well as the diagnostic abilities of the OPT10 greatly facilitate troubleshooting.

The following is a list of the most likely error codes to be encountered and what they mean. Also included are troubleshooting steps to take to further diagnose the error. Please go through the steps in this section before calling Eagle Tugs. This will greatly expedite the troubleshooting process.

6: CAN ERROR

A CAN error occurs if there is an issue with the communication wiring between system components.

- Check electrical connections and pins on the CAN wiring and verify that the plug-in resistor under the dash is in place. If everything looks good, use a multimeter to pin-out the wiring and verify continuity through the communication system.

10: WARN. TRACTION DC BUS LOW

The most likely cause is a bad connection on the pre-charge resistor. The resistor allows the AC Drive to charge the on-board capacitors without the main contactor being closed.

- Check the electrical connections on the pre-charge resistor.
- Use a multimeter to verify the resistor measures 10 ± 1 Ohms. If the resistance is outside of this range, replace the resistor.

11: WARN. TRACTION DC BUS HIGH

This error happens when the regenerative braking system is unable to put excess energy back into the battery.

- If the battery is fully charged the braking energy has nowhere to go. Modify the driving and charging procedures to prevent extensive downhill usage with a completely full battery.
- This can also occur due to an issue in the battery wiring during regenerative braking. Check all battery cables, bus bars, and fuses for loose connections. Damaged battery cell interconnects can also cause this error.

12: WARN. TRACTION SPEED SENSOR

Inspect the wiring and connectors for the traction motor speed sensor (4-wire connector mounted to motor).

- If no issues can be found with the wiring, replace motor (to replace the speed sensor)
- If motor replacement does not correct the issue, replace the traction drive.

14: WARN. TRACTION MOTOR TEMP HIGH

The eTT traction motor features a built-in thermal sensor. This sensor will cause an error when over a certain temperature threshold; motor power output will also be reduced.

- Inspect motor for debris/dust covering the cooling holes in the motor. Clean any dirt or debris present. Resume operation.
- Verify that the drivetrain system moves freely. Hanging brakes, bad bearings, or other issues that prevent free movement of the drivetrain can lead to high motor load.
- If motor is clean and drivetrain is not binding, reduce the operational duty cycle to reduce motor heating.

Error Code Troubleshooting

15: WARN. TRACTION TEMPERATURE SENSOR

The eTT traction motor features a built-in thermal sensor.

- Verify resistance of the thermal sensor on the motor (2-pin connector mounted to the traction motor). If open circuit or short circuit replace the drive motor.
- If sensor itself is not open/short circuit, check electrical wiring and connections to the thermal sensor. If wiring and sensor are good, replace the traction drive.

17: WARN. TRACTION HEAT SINK TEMP HIGH

The eTT traction drive features a built-in thermal sensor. This sensor will cause an error when over a certain temperature threshold; motor power output will also be reduced.

- Inspect drive cooling fans for proper operation. If fans are inoperative, verify that they are getting power from the power distribution block. Check the 5A fuse (F1). If fans are getting power but are inoperative they need to be replaced. Note that the fans will not run if the drive is at a cool temperature, which is normal.
- Check the cooling fans and the heatsink fins on the drive for debris/dust. Clean the cooling fans carefully with low pressure air or water (overspeeding them can damage them). Remove the access panel at the rear of the drive and flush any dirt or debris present out of the fins with compressed air or water. Replace panel and resume operation.
- Verify that the drivetrain system moves freely. Hanging brakes, bad bearings, or other issues that prevent free movement of the drivetrain can lead to high drive load.
- If fans are operational and fins are clean, and the drivetrain is not binding, reduce the operational duty cycle to reduce drive heating. Note that it is also important to use the parking brake on the truck at all times when not actively moving. The parking brake disables the traction drive. This reduces battery usage and heat build-up.

18: WARN. TRACTION HEAT SINK TEMP SENS

The eTT traction drive features a built-in thermal sensor.

- The sensor is non-serviceable. Replace the traction drive.

20: WARN. BATTERY LOW

The battery monitor algorithm has determined that the battery needs to be recharged. The tractor will force a limp-mode to prevent further usage and possible damage to the battery. Charge the battery immediately.

21: ERR. TRACTION SHORT CIRCUIT

The traction drive detected a very large voltage drop during operation. This can be caused by a short on the battery terminals or a break in the battery connection during travel.

- Physically verify that no shorts are present on the battery cables and bus bars.
- Check all battery cables, bus bars, and fuses for loose connections. Damaged battery cell interconnects can also cause this error.
- Verify the main contactor coil wiring and connector pins.

22: ERR. TRACTION LOW VOLTAGE

The most likely cause is a bad connection on the pre-charge resistor. The resistor allows the AC Drive to charge the on-board capacitors without the main contactor being closed.

- Check the electrical connections on the pre-charge resistor.
- Use a multimeter to verify the resistor measures 10 ± 1 Ohms. If the resistance is outside of this range, replace the resistor.

Error Code Troubleshooting

23: ERR. TRACTION HIGH VOLTAGE

This error happens when the regenerative braking system is unable to put excess energy back into the battery.

- If the battery is fully charged the braking energy has nowhere to go. Modify the driving and charging procedures to prevent extensive downhill usage with a completely full battery.
- This can also occur due to an issue in the battery wiring during regenerative braking. Check all battery cables, bus bars, and fuses for loose connections. Damaged battery cell interconnects can also cause this error.

24: ERR. TRACTION MOTOR TEMP HIGH

The eTT traction motor features a built-in thermal sensor. This sensor will cause an error when over a certain temperature threshold; motor power output will also be disabled.

- Inspect motor for debris/dust covering the cooling holes in the motor. Clean any dirt or debris present. Resume operation.
- Verify that the drivetrain system moves freely. Hanging brakes, bad bearings, or other issues that prevent free movement of the drivetrain can lead to high motor load.
- If motor is clean and drivetrain is not binding, reduce the operational duty cycle to reduce motor heating.

25: ERR. TRACTION HEAT SINK TEMP HIGH

The eTT traction drive features a built-in thermal sensor. This sensor will cause an error when over a certain temperature threshold; motor power output will also be disabled.

- Inspect drive cooling fans for proper operation. If fans are inoperative, verify that they are getting power from the power distribution block. Check the 5A fuse (F1). If fans are getting power but are inoperative they need to be replaced. Note that the fans will not run if the drive is at a cool temperature, which is normal.
- Check the cooling fans and the heatsink fins on the drive for debris/dust. Clean the cooling fans carefully with low pressure air or water (overspeeding them can damage them). Remove the access panel at the rear of the drive and flush any dirt or debris present out of the fins with compressed air or water. Replace panel and resume operation.
- Verify that the drivetrain system moves freely. Hanging brakes, bad bearings, or other issues that prevent free movement of the drivetrain can lead to high drive load.
- If fans are operational and fins are clean, and the drivetrain is not binding, reduce the operational duty cycle to reduce drive heating. Note that it is also important to use the parking brake on the truck at all times when not actively moving. The parking brake disables the traction drive. This reduces battery usage and heat build-up.

26: ERR. TRACTION NOT RESPONDING

The traction drive is not responding to the VMC30.

- Verify that the drive is powered up (look at LED indicator light on the drive). The LED should be steadily lit to indicate a drive with no errors or warnings.
- Check electrical connections and pins on the CAN wiring and verify that the plug-in resistor under the dash is in place. If everything looks good, use a multimeter to pin-put the wiring and verify continuity through the communication system.
- If no issues can be found with the CAN wiring, the drive is receiving power, and the problem persists, replace the traction drive.

Error Code Troubleshooting

41: HIGH HYDRAULIC FLUID TEMPERATURE

The normally open hydraulic temperature switch input has closed indicating the hydraulic fluid has exceeded 160°F/71°C. Test the temperature of the hydraulic fluid in the hydraulic tank. If the fluid in the hydraulic tank exceeds 140°F take the tractor out of service to prevent component damage and check the following.

- Verify that the cooler fan is operating correctly. The fan is run directly from a secondary temperature switch located in the hydraulic cooler.
- Verify that the cooler is clean and free of debris. Wash out with compressed air or water spray.
- Turn the tractor off with a charged accumulator and listen for hydraulic bleed. A partially open valve can cause excessive pump operation leading to heated fluid.
- Verify that hydraulic accumulator charge time and storage volume have not changed significantly. An accumulator with insufficient pre-charge can lead to excessive pump operation leading to heated fluid.

If the tank is below 140°F, verify the following.

- If the input reads 1, inspect for a faulty switch or short in the electrical wires/connectors.
- Use the OPT10 diagnostics to review the input status of the switch. If the input reads 0 (OPEN), replace the VMC30.

42: LOW BATTERY VOLTAGE LEVEL

The battery does not have sufficient charge to continue tractor operation. Remove the tractor from service and charge immediately. If this error occurs shortly (less than a full hour of use) after a full charge see the below inspection items.

- Verify that the drivetrain is freely moving and that no bearings, brakes, or other components are creating resistance in the drivetrain.
- After a full equalization charge on the battery, inspect the specific gravity of each cell. If the specific gravity is lower than a full charge, have the charger serviced. If any individual cell differs by more than .020 from the nominal 1.290 (positive or negative), have the battery serviced.

43: THROTTLE FAULT

If the steering is also disabled, the cause is most likely a failure of the 5V DC-DC converter that powers the steering sensors and throttle pedal.

- Verify the 5A fuse in the power distribution box (F5) is intact.
- Use a multimeter to ensure that the 5V converter is getting +12V from the power distribution box (pins 1 and 2 on the converter). If not, verify electrical connections and pins between the converter and the power distribution box to see if any issues are apparent.
- If the converter is getting power on pins 1 and 2, test pins 3 and 4 for +5V output. If the output is incorrect, replace the converter.

If the steering is not disabled, the issue is likely with the pedal itself. Use the OPT10 to view the THROTTLE POT COUNTS input while operating the pedal.

- The count value should move up and down on application of the throttle pedal. Normal range is 0-1000 counts. If outside this value, replace the pedal.
- If value is zero, check electrical connections and pins between the pedal and VMC30 to see if any issues are apparent. If no issues are apparent replace the pedal.

Error Code Troubleshooting

44: SHIFTING FAULT

The shifting has timed-out. This happens when the tractor attempts to shift gears and the gear detection switches don't confirm that the shift has completed. Use the OPT10 to verify that the inputs LOW SHIFT SWITCH and HIGH SHIFT SWITCH match the physical positioning of the shift switch (when the switch is in tow, the LOW SHIFT SWITCH input should be 1). Verify that the LOW GEAR SENSOR and the HIGH GEAR SENSOR also match the switch position. The dash mounted LED lights will illuminate along with the LOW GEAR SENSOR and the HIGH GEAR SENSOR inputs.

- If the inputs do not agree, check all wiring connections. Having either the transfer case gear sensor connectors flipped, the dash switch wires flipped, or the shift solenoid connectors flipped can lead to this error. Verify that all of these items are correct.
- Verify that you can hear the hydraulic shift mechanism in the transfer case move when the dash switch is flipped. If not, use a multimeter to verify that the solenoid outputs are being powered up correctly. *Note that the shift solenoid is a 24V solenoid, but is powered by an 80V signal. The VMC30 pulses the 80V at a high frequency duty cycle to mimic a true 24V source. Use the alternating current setting on your multimeter to verify these voltages.* If the solenoid is not getting power check the wiring to the power distribution box and to the VMC30. Verify the in-line 80V fuse from the main contactor to the ACS relay. Check both shift up and shift down coils.
- If the solenoid is being powered correctly verify that the solenoid is not lodged in place. Tap on the top of the solenoid with a soft mallet. You can also swap the shift solenoid connectors to try and pull the solenoid the opposite direction. If the solenoid appears to be lodged in place, replace the solenoid.

45: PRESSURE SENSOR FAULT

The tractor has two pressure sensors to determine when to run the hydraulic pump. The low sensor switches at 1800 psi and turns the pump on. The high pressure switches at 2500 psi and turns the pump off again. The pressure stored in the accumulator is always kept between these two pressures. If the two pressure switches indicate an impossible situation, this error is shown. Use the OPT10 to look at the inputs LOW PRESSURE SWITCH and HI PRESSURE SWITCH. The majority of the time the pressure should be between 1800 psi and 2500 psi and the switches should read 1 (LOW PRESSURE SWITCH) and 1 (HI PRESSURE SWITCH).

- With the tractor off and the hydraulic accumulator drained (steer front steering back and forth until the energy is dissipated), verify the switches with a multimeter. If the switches don't read open (low pressure) and closed (high pressure), replace the faulty switch.
- If the switches both read correctly at zero pressure, plug them back in and turn on the truck. Use the OPT10 to verify the switch inputs. If the low pressure switch never changes to 1 during system charging, replace the low pressure switch.
- If the high pressure switch never changes to 0 during system charging (the switch should change back to 1 rather quickly) the pump will keep running until the system bleeds through the relief valve. Take the tractor out of service and turn off to prevent component damage. Replace the high pressure switch.

47: INCHING SWITCH FAULT

There are two different scenarios that will cause an inching switch fault. Either the Inching switch closing within 15 seconds of a vehicle startup, or inching switch inputs for both forward and reverse active at the same time.

- If no physical operation of the inching switches occurred, verify that the switches are not shorted and are working correctly. Use the OPT10 to check the inching switch inputs INCH FORWARD SWITCH and INCH REVERSE SWITCH to verify that they both read 0 when they are not actuated.

Error Code Troubleshooting

48: FRONT STEER SENSOR FAULT

If the throttle is also disabled, the cause is most likely a failure of the 5V DC-DC converter that powers the steering sensors and throttle pedal.

- Verify the 5A fuse in the power distribution box (F5) is intact.
- Use a multimeter to ensure that the 5V converter is getting +12V from the power distribution box (pins 1 and 2 on the converter). If not, verify electrical connections and pins between the converter and the power distribution box to see if any issues are apparent.
- If the converter is getting power on pins 1 and 2, test pins 3 and 4 for +5V output. If the output is incorrect, replace the converter.

If the throttle is not disabled, the issue is likely with the steering sensor itself. Use the OPT10 to view the FRONT STEER COUNTS input while steering the front axle.

- The count value should smoothly move up and down when steering the front axle from side to side. Normal range is roughly 100-300 counts. If greatly outside this range, replace the steer sensor.
- If value does not change when steering the front axle, check electrical connections and pins between the sensor and VMC30 to see if any issues are apparent. If no issues are apparent replace the steer sensor.

49: REAR STEER SENSOR FAULT

If the throttle is also disabled, the cause is most likely a failure of the 5V DC-DC converter that powers the steering sensors and throttle pedal.

- Verify the 5A fuse in the power distribution box (F5) is intact.
- Use a multimeter to ensure that the 5V converter is getting +12V from the power distribution box (pins 1 and 2 on the converter). If not, verify electrical connections and pins between the converter and the power distribution box to see if any issues are apparent.
- If the converter is getting power on pins 1 and 2, test pins 3 and 4 for +5V output. If the output is incorrect, replace the converter.

If the throttle is not disabled, the issue is likely with the steering sensor itself.

- A steer sensor fault will prevent normal steering as a method of testing the input. The best way to test the rear steer sensor is to remove the plugs from the steering proportional valve on the manifold block, remove the rear LH wheel and tire, and remove the steering sensor from its mount on top of the axle. The sensor can then be manually rotated while viewing the input on the OPT10 display. If the count value does not change when rotating the sensor, check electrical connections and pins between the sensor and VMC30 to see if any issues are apparent. If no issues are apparent replace the steer sensor.

Error Code Troubleshooting

50: STEER ERROR FAULT

The tractor has been unable to coordinate the front and rear axle steering and has timed out. If the throttle is disabled, the cause is most likely a failure of the 5V DC-DC converter that powers the steering sensors and throttle pedal.

- Verify the 5A fuse in the power distribution box (F5) is intact.
- Use a multimeter to ensure that the 5V converter is getting +12V from the power distribution box (pins 1 and 2 on the converter). If not, verify electrical connections and pins between the converter and the power distribution box to see if any issues are apparent.
- If the converter is getting power on pins 1 and 2, test pins 3 and 4 for +5V output. If the output is incorrect, replace the converter.

If the throttle is working correctly, the error is either a steering sensor error or a hydraulic system issue.

- Verify that the hydraulics appear to be working and that the system has pressure. Verify that shifting is working properly and that the front axle can be steered properly. If the hydraulic system is not working, diagnose that system.

Verify the steering sensor functionality. Use the OPT10 to view the FRONT STEER COUNTS and REAR STEER COUNTS inputs while steering the front axle.

- The count values should smoothly move up and down when steering the front axle from side to side. Normal range is roughly 100-300 counts. If greatly outside this range, replace the steer sensors.
- If one of the values does not change when steering the front axle, check electrical connections and pins between the sensor and VMC30 to see if any issues are apparent. If no issues are apparent replace the steer sensor.

Verify the steer solenoid is getting electrical power and working correctly.

- Use a multimeter to watch the solenoid output while attempting to actuate the solenoid by steering the front axle. *Note that the steer solenoid is a 24V solenoid, but is powered by an 80V signal. The VMC30 pulses the 80V at a high frequency duty cycle to mimic a true 24V source. Use the alternating current setting on your multimeter to verify these voltages.* If the solenoid is not getting power, check the wiring to the power distribution box and to the VMC30. Verify the in-line 80V fuse from the main contactor to the ACS relay. Be sure to check both coils.
- If the solenoid is being powered correctly verify that the solenoid is not lodged in place. Tap on the top of the solenoid with a soft mallet. You can also swap the steer solenoid connectors to try and pull the solenoid the opposite direction. If the solenoid appears to be lodged in place, replace the solenoid.

51: DC DC CONVERTER FAULT

The tractor was unable to detect the 5V reference signal from the 5V DC-DC converter.

- Verify the 5A fuse in the power distribution box (F5) is intact.
- Use a multimeter to ensure that the 5V converter is getting +12V from the power distribution box (pins 1 and 2 on the converter). If not, verify electrical connections and pins between the pedal and the power distribution box to see if any issues are apparent.
- If the converter is getting power on pins 1 and 2, test pins 3 and 4 for +5V output. If the output is incorrect, replace the converter.

Error Code Troubleshooting

60: WARN. PUMP DC BUS LOW

The most likely cause is a bad connection on the pre-charge resistor. The resistor allows the pump drive to charge the on-board capacitors without the main contactor being closed.

- Check the electrical connections on the pre-charge resistor.
- Use a multimeter to verify the resistor measures 10 ± 1 Ohms. If the resistance is outside of this range replace the resistor.

62: WARN. PUMP SPEED SENSOR

Inspect the wiring and connectors for the pump motor speed sensor (4-wire connector mounted to motor).

- If no issues can be found with the wiring replace motor (to replace the speed sensor)
- If motor replacement does not correct the issue, replace the pump drive.

64: WARN. PUMP MOTOR TEMP HIGH

The eTT pump motor features a built-in thermal sensor. This sensor will cause an error when over a certain temperature threshold; motor power output will also be reduced.

- Inspect motor for debris/dust covering the cooling holes in the motor. Clean any dirt or debris present. Resume operation.
- Verify that the accumulator is holding pressure and that there is no pressure bleed in the system that would lead to excessive pump run time.

65: WARN. PUMP TEMPERATURE SENSOR

The eTT pump motor features a built-in thermal sensor.

- Verify resistance of the thermal sensor on the motor (2-pin connector mounted to the pump motor). If open circuit or short circuit replace the pump motor.
- If sensor itself is not open/short circuit, check electrical wiring and connections to the thermal sensor. If wiring and sensor are good, replace the pump drive.

67: WARN. PUMP HEAT SINK TEMP HIGH

The eTT pump drive features a built-in thermal sensor. This sensor will cause an error when over a certain temperature threshold; motor power output will also be reduced.

- Verify that the accumulator is holding pressure and that there is no pressure bleed in the system that would lead to excessive pump run time.
- Verify that the pump drive is firmly attached to the tractor center bulkhead. The drive uses the tractor chassis as a heat sink. If the hardware is loose the drive will not be able to dissipate heat effectively.

71: ERR. PUMP SHORT CIRCUIT

The pump drive detected a very large voltage drop during operation. This can be caused by a short on the battery terminals or a break in the battery connection during travel.

- Physically verify that no shorts are present on the battery cables and bus bars.
- Check all battery cables, bus bars, and fuses for loose connections. Damaged battery cell interconnects can also cause this error.
- Verify the pump contactor coil wiring and connector pins.

72: ERR. PUMP LOW VOLTAGE

The most likely cause is a bad connection on the pre-charge resistor. The resistor allows the AC Drive to charge the on-board capacitors without the main contactor being closed.

- Check the electrical connections on the pre-charge resistor.
- Use a multimeter to verify the resistor measures 10 ± 1 Ohms. If the resistance is outside of this range replace the resistor.

Error Code Troubleshooting

74: ERR. PUMP MOTOR TEMP HIGH

The eTT pump motor features a built-in thermal sensor. This sensor will cause an error when over a certain temperature threshold; motor power output will also be disabled.

- Inspect motor for debris/dust covering the cooling holes in the motor. Clean any dirt or debris present. Resume operation.
- Verify that the accumulator is holding pressure and that there is no pressure bleed in the system that would lead to excessive pump run time.

75: ERR. PUMP HEAT SINK TEMP HIGH

The eTT pump drive features a built-in thermal sensor. This sensor will cause an error when over a certain temperature threshold; motor power output will also be disabled.

- Verify that the accumulator is holding pressure and that there is no pressure bleed in the system that would lead to excessive pump run time.

76: ERR. PUMP NOT RESPONDING

The pump drive is not responding to the VMC30.

- Verify that the drive is powered up (look at LED indicator light on the drive). The LED should be steadily lit to indicate a drive with no errors or warnings.
- Check electrical connections and pins on the CAN wiring and verify that the plug-in resistor under the dash is in place. If everything looks good, use a multimeter to pin-put the wiring and verify continuity through the communication system.
- If no issues can be found with the CAN wiring and the problem persists, replace the pump drive.

Operational Troubleshooting

Tractor won't move when the throttle pedal is pressed

- Verify that the parking brake is released. Confirm by looking at the OPT10 parking brake icon. If the indicator LED does not turn off the parking brake proximity sensor is not working correctly.
- Verify that the tractor is in the selected gear by looking at the dash mounted shift switch and LED indicators. Use the OPT10 to verify that the inputs on the shift low/high switch match the low/high gear sensor inputs. A brand new transmission may hesitate when shifting until the gears get some hours on them. Switch between high/tow a couple times to attempt to get the transmission fully into the desired gear.
- Verify that the tractor is in Drive Mode.
- Verify that no active codes are present that could be impeding travel.
- Use the OPT10 to view the THROTTLE POT COUNTS. The counts should increase smoothly from 0 to 1000 when the throttle pedal is pressed. Note that the THROTTLE POT COUNTS input is filtered by the controller and does not indicate a faulty pedal by itself.
- Use the OPT10 to view the FOOT PEDAL SWITCH. The input should be roughly 1022 normally, and drop to roughly 12 when the throttle pedal is pressed. If this input is not functional, verify the wiring including the 2k ohm pull-up resistor installed in the power distribution box.

Tractor won't inch when switches are pressed

- Verify that the tractor is in inch mode.
- By design, the tractor will not inch after key-on unless the tractor has been driven in drive mode first. This is a safety feature to prevent accidental inching on startup.
- Verify that the surface you are on is flat and level. The inching functionality is not intended to be used while under load, including up-slope.
- Verify that the parking brake is released.
- Verify that the tow gear switch is selected and that the tow gear indicator LED is illuminated. Note that shifting gears cannot be done in inch mode and drive mode may need to be selected to complete the shift.

The rear axle steering is out of sync with the front axle

- If the rear axle is slightly off but otherwise operates correctly, perform a steering calibration per the instructions in this manual.
- If the rear steering is non-functional, refer to error 50: STEER ERROR FAULT.

Tractor drives very slowly (creeping) and will not speed up

- The tractor may be in limp-home mode. If the battery reaches a minimum value (30% charge), the tractor will enter limp-home mode and not exceed 1 mph. Remove the tractor from service and charge the battery before continuing usage.
- Error 42: LOW BATTERY VOLTAGE LEVEL will force a limp-home mode condition. Remove the tractor from service and charge the battery before continuing usage.
- Incorrectly installed UVW cables can cause this issue. Inspect the UVW cables to verify that they are properly installed on the motor and the traction drive.
- A faulty motor speed sensor can cause this issue. Use the OPT10 display to watch the TRAC MOTOR SPEED input while driving at the slow speed. The input should be smooth during travel. If the motor speed oscillates between positive and negative while traveling, replace the drive motor.

Operational Troubleshooting

Tractor battery does not last long before needing to be charged (error 42 or limp-home mode)

Battery life is directly dependent on usage of the tractor. If you do not feel that you are getting the battery life out of the tractor you expect please inspect the following items.

- Do not tow loads in high gear. High gear is intended to be used for unloaded travel only. Towing while in high gear will drain the battery very quickly.
- After a full equalization charge on the battery, inspect the specific gravity of each cell. If the specific gravity is lower than a full charge, have the charger serviced. If any individual cell differs by more than .020 from the nominal 1.290 (positive or negative), have the battery serviced.
- Verify that the drivetrain is freely moving and that no bearings, brakes, or other components are creating resistance in the drivetrain.

Dash panel buzzes when the tractor is on

- The dash panel will buzz when left in Inch mode for an extended amount of time. This is to let the operator know that the tractor has been left unattended. Switching to Drive mode will stop the buzzer.

Charger is giving an error message or not working properly

- Eagle Tugs does not service the battery charger for the truck. For the most expedient assistance with a charger issue, please contact the manufacturer of the charger directly. Eagle Tugs can assist with working with the charger manufacturer if you do not get a prompt response.

Battery is not performing properly or cells are out of specification

- Eagle Tugs does not service the battery for the truck. For the most expedient assistance with a battery issue, please contact the manufacturer of the battery directly. Eagle Tugs can assist with working with the battery manufacturer if you do not get a prompt response.

Hydraulic pump runs more frequently than usual, or does not shut off

One possible cause is that the system cannot maintain pressure. A relief valve stuck in the open position or any other valve or seal that is bleeding pressure from the accumulator will result in reduced battery life and increased component wear.

- Turn the tractor off and listen for any hydraulic bleed-by that is draining the accumulator pressure.
- Watch the pressure gage located on the manifold block once the system has charged. The pressure should hold at a steady rate.

If no pressure bleeds seem to be present and the system can hold pressure for a long period of time, there may be an issue with the gear pump.

- Test the time to charge the accumulator from a fully depressurized state. If the accumulator takes longer to charge than when new, the hydraulic pump may be worn or damaged.

An alternative cause of frequent pump operation is a loss of accumulator pre-charge. The accumulator relies on highly compressed nitrogen to store hydraulic energy. If some of the nitrogen leaks out, the accumulator will store much less energy and the pump will have to work much more often.

- Test the number of turns possible on the steering wheel after turning the tractor on to charge the accumulator, then turning the tractor off. If the amount of turns differs significantly from when new, the accumulator pre-charge should be checked.

Revision Log

Rev	Date	Description	Appr.
A	26-Feb-2014	Original release for production	PRB
B	6-Jun-2016	Changed eXL16 model name to eTT16	TFP

Appendix A - Logic, Controls, and 4WS System	
Description	Page
Drive System Overview	A-2
Hydraulic System Overview	A-4
Hydraulic Manifold Overview	A-6
Steering System Overview	A-10
Steering Calibration Procedure	A-11
Regenerative Braking Tuning Procedure	A-12
Revision Log	A-13

Drive System Overview

The eTT tractor drivetrain is composed of both electrical and mechanical components. This section will provide details on each component and how it fits into the system.

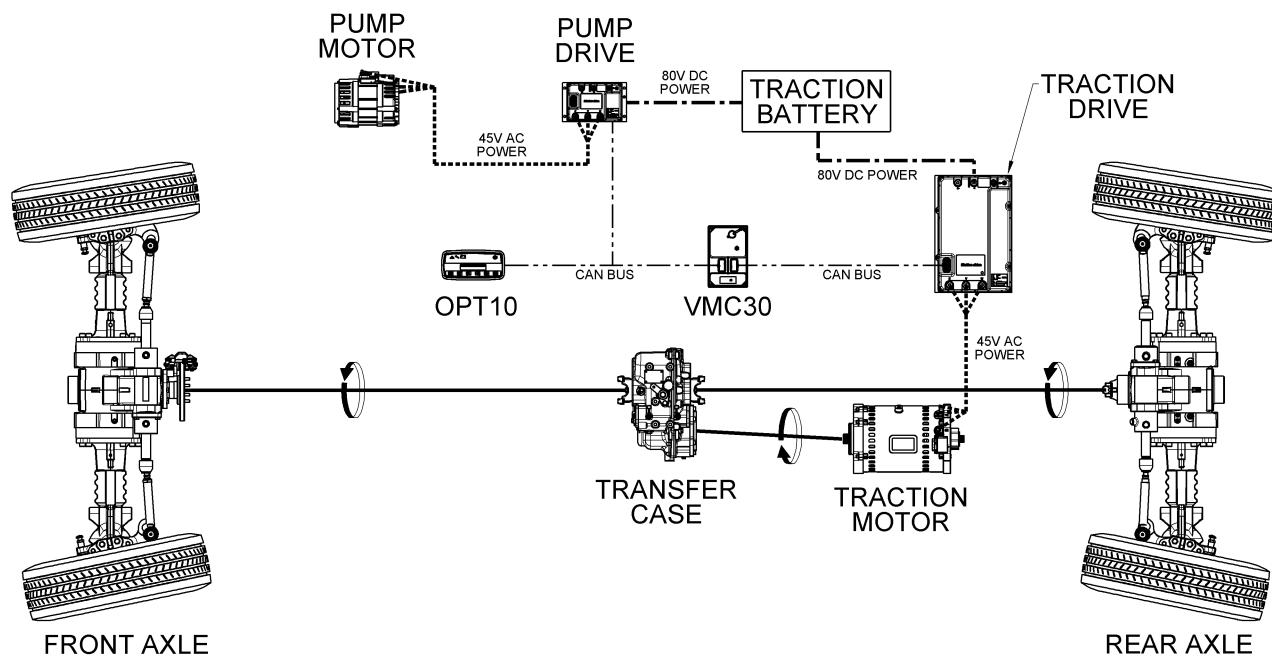

ETT8 / ETT12 / EXL16 DRIVETRAIN
SYSTEM DIAGRAM

Traction Battery

The eTT traction battery is an 80V lead-acid type battery. The battery provides electrical power to the drive system as well as providing necessary ballast weight to the tractor. The battery capacity is rated in amp-hours and Eagle uses 400 Ah or 625 Ah batteries depending on the specific tractor.

The eTT-16 also has an optional secondary battery, bringing the total capacity to 1250 Ah.

AC Drives

The AC Drives (also referred to as the Inverters, Traction Drive, and Pump Drive) control the motors per instruction from the VMC30 (see below). The inverters convert 80V DC battery power to 3-phase AC power for the motors. The motor speed and torque are controlled by the frequency and amperage of the AC signal.

Traction Motor / Pump Motor

The traction and pump motors convert 3-phase AC power to rotational motion. The motors have no brushes and are maintenance free. They include temperature and speed sensors to provide feedback to the AC Drives.

VMC30

The VMC30 is a programmable logic controller. It runs a custom program that interprets many inputs (throttle pedal, gear selection, etc.) and uses them to create various outputs (indicator lights, gear shifts, motor speed and torque, etc.). The VMC30 is responsible for all logic and safety controls on the tractor.

Drive System Overview

OPT10

The OPT10 is a graphical interface for the drive system. It interfaces with the VMC30 and provides operator information, diagnostic codes and diagnostic tools.

CAN Bus

The AC Drive, VMC30, and OPT10 communicate using a protocol called CAN. This communication enables the three devices to work as one integrated system. The communication wires consist of a Yellow, Green, and Black triplet twisted together to reduce electrical noise. This wiring is referred to as the CAN Bus.

Transfer Case

The transfer case is a two-speed gearbox. The gearbox multiplies torque from the traction motor. The two speeds are selected with hydraulic pressure and provide a tow speed and a travel speed.

Axles

The front and rear axles provide a final torque multiplication. They are high-strength planetary axles. Both axles steer in a coordinated method to provide a tight turning radius. The axles also provide braking power with immersed wet disk service brakes and an external dry disk parking brake (front axle only).

Hydraulic System Overview

The eTT tractor hydraulic system works as an on-demand system. The purpose is to limit the amount of time the hydraulic pump is in operation. This reduces battery load and extends time between charges. This is accomplished through a combination of hydraulic components that store and monitor hydraulic pressure.

On-demand Functionality

On tractor startup the system pressure is at zero. The VMC30 turns on the hydraulic pump and it begins charging the tractor accumulator. The accumulator stores the pressurized fluid for later usage.

The pump runs until the accumulator pressure reaches the high-pressure set-point of 2500 psi (172 bar). At this pressure, the normally closed high pressure switch opens to let the VMC30 know that the accumulator has been charged.

The pressurized fluid is used by the steering, braking, and shifting systems and then returned to the hydraulic tank.

Once enough of the pressurized fluid has been used, the pressure in the accumulator lowers below the low-pressure set-point of 1800 psi (124 bar). Below this pressure, the normally open low-pressure switch will close to let the VMC30 know that the system needs to be recharged.

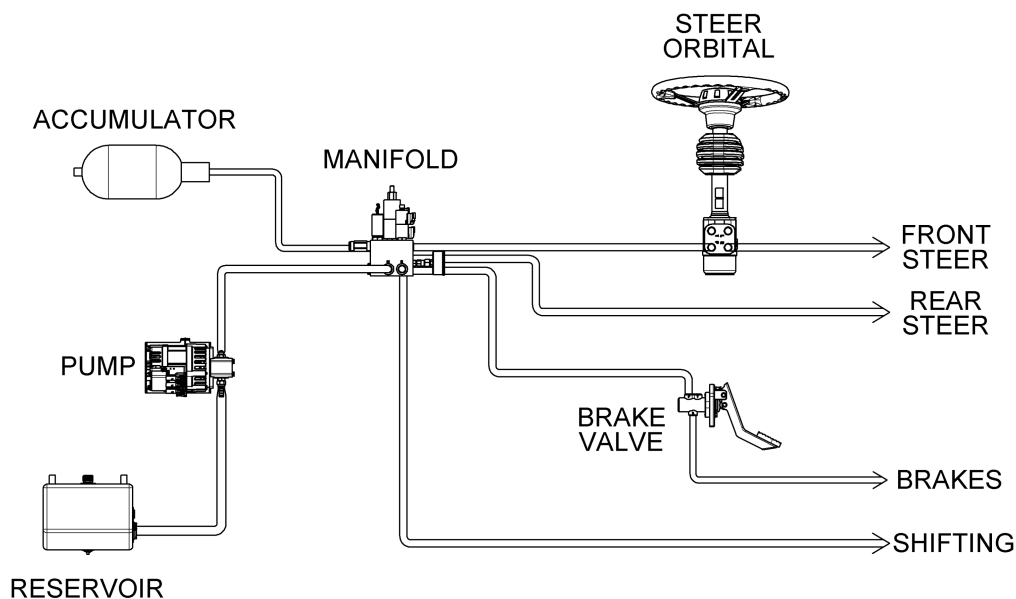

ETT8 / ETT12 / EXL16 SIMPLIFIED
HYDRAULIC SYSTEM DIAGRAM

Reservoir

The hydraulic reservoir serves several functions. The reservoir stores a large amount of hydraulic fluid to run the hydraulic components. The reservoir has a large surface area to transfer heat from hot hydraulic fluid to the environment; this supplements the cooling from the dedicated hydraulic cooler. The reservoir also serves as an expansion tank to allow fluid volume to change when the accumulator is charged and drained.

Hydraulic System Overview

Hydraulic Pump

The hydraulic pump pulls fluid from the reservoir and pressurizes it to charge the system accumulator. The pump is a hydraulic gear pump mounted to an AC induction motor. The speed of the motor is controlled by the VMC30 controller based on logic inputs to the system.

Manifold Block

The hydraulic manifold block contains switches and valves that control and direct fluid to the system. See the manifold schematic and overview for detailed information.

Front Steering

The front steering system controls steering of the front axle through a closed-center orbital valve. The steering wheel input to the orbital directly controls flow to the front axle steering cylinder. When not giving the orbital any steering input, the flow at the orbital ports is blocked. This blockage prevents pressure leakage from the accumulator, and prevents any movement on the front axle steering cylinder.

Rear Steering

The rear steering system is controlled by the VMC30. System pressure is fed to the rear steering cylinder through a proportional flow valve in the hydraulic manifold. The VMC30 uses steering sensors located on the front and rear axles and programmed logic and controls to determine the proper position of the proportional valve. When the valve is unpowered (no steering motion) all ports are blocked. This blockage prevents pressure leakage from the accumulator, and prevents any movement on the rear axle steering cylinder.

Brake System

The brakes are controlled by a valve mounted directly to the brake pedal. The input for this valve runs off of full system pressure and sends out a reduced pressure to the brakes on the front and rear axles. The output pressure varies based on how far the pedal is pressed, but is always much lower than system pressure. When the pedal is not pressed, the output pressure is connected to tank and the input port is blocked.

The brake system uses a check valve and a small dedicated accumulator to provide brake pressure even if normal system pressure is zero. This is enough stored pressure to provide several cycles of full-power braking.

Shifting System

The shifting of the 2-speed gearbox is controlled by a three-position valve in the hydraulic manifold. The manifold also includes a pressure reducing valve to prevent over-pressure and resulting damage of the shifting system.

The VMC30 controls the position of the 3-position hydraulic valve in response to operator input as well as control logic. The valve, when shifted from center, applies hydraulic pressure to either the high or low gear ports on the gearbox. The pressure is maintained at all times to prevent shifting into neutral.

Hydraulic Manifold Overview

The eTT tractor hydraulic manifold contains several valves and switches to facilitate operation of the eTT hydraulic system. The included schematic and description should help understand how the system functions.

Pressure Side

Pressure enters the manifold block on the P1 port. The fluid first passes through the check valve CV1. The CV1 check valve ensures that the pressure that is held in the accumulator does not leak back through the hydraulic pump to tank.

The incoming pressure is shared by ports ACC, STRG, MOD, PS1, PS2 as well as valved SP1, RV1, and PR1.

RV1

The relief valve ensures that the system pressure never reaches an unsafe value. Should the pressure in the pressure side of the manifold ever exceed the relief pressure (3300 psi / 227 bar), the valve will open and divert flow to the tank output T1. This prevents the pressure from building, further protecting the system.

ACC

The accumulator is connected to this port. When charging the system, pressurized fluid from P1 flows through the block to ACC. The flow continues until the VMC30 turns off the hydraulic pump. When the pump is turned off, the accumulator feeds the stored hydraulic fluid back through the ACC port to power the system components.

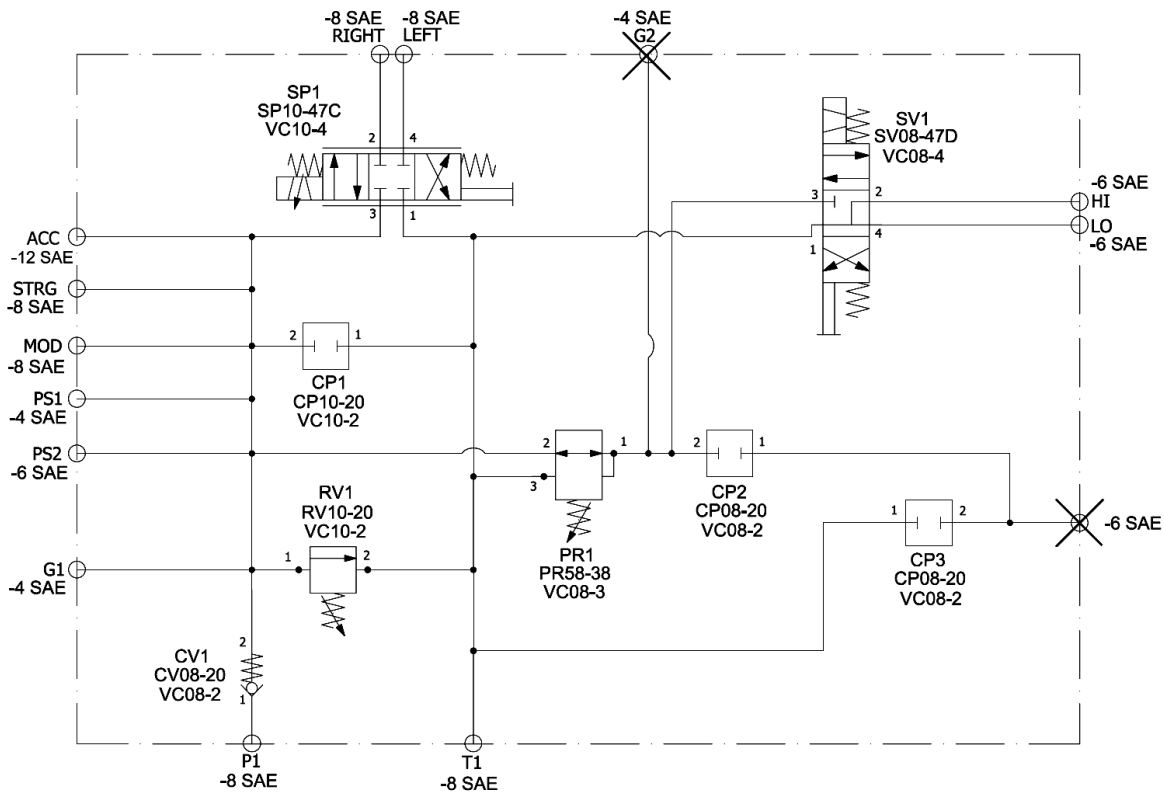

Hydraulic Manifold Schematic

Hydraulic Manifold Overview

PS1 and PS2

The low and high pressure switches are installed to these two ports. The switches monitor the manifold pressure to determine when the hydraulic pump should be running.

MOD

The MOD port provides hydraulic fluid to the brake system.

STRG

The STRG port provides hydraulic fluid to the front steering orbital.

G1 and G2

G1 is a gage port. A needle gage is installed here from the factory. The gage provides feedback on the system pressure and assists in system troubleshooting.

G2 is an optional gage port that allows monitoring of the reduced pressure output from PR1. By default the G2 port is plugged from the factory.

SP1

The SP1 valve is a proportional flow valve. This valve provides fluid to the rear axle steering cylinder and is controlled by the VMC30.

PR1

The PR1 valve is a pressure reducing valve. It reduces system pressure to 250 psi (17 bar) for use by the shifting valve. The shift valve must operate at the lower pressure to prevent damage to the gearbox.

SV1

The SV1 valve controls gearbox shifting. The valve uses low-pressure fluid from the PR1 valve and directs it to either the low gear or high gear ports on the gearbox. The valve is controlled by the VMC30 and depends on operator input and controller logic.

T1

The T1 port is connected to the hydraulic reservoir tank through the hydraulic return filter.

CP1, CP2, CP3

There are several cavity plugs and plugged ports in the manifold block. These plugs close off circuits and ports that are not used on the eTT manifold block. The plugs must remain installed to prevent fluid leakage.

Hydraulic Manifold Overview

The eTT tractor hydraulic manifold contains several valves and switches to facilitate operation of the eTT hydraulic system. The included schematic and description should help understand how the system functions.

Pressure Side

Pressure enters the manifold block on the P1 port. The fluid first passes through the check valve CV1. The CV1 check valve ensures that the pressure that is held in the accumulator does not leak back through the hydraulic pump to tank.

The incoming pressure is shared by ports ACC, STRG, MOD, MOD ACC, PS1, PS2, GP1, and TEMP.

RV1

The relief valve ensures that the system pressure never reaches an unsafe value. Should the pressure in the pressure side of the manifold ever exceed the relief pressure (3300 psi / 227 bar), the valve will open and divert flow to the tank output T1. This prevents the pressure from building, further protecting the system.

ACC

The accumulator is connected to this port. When charging the system, pressurized fluid from P1 flows through the block to ACC. The flow continues until the VMC30 turns off the hydraulic pump. When the pump is turned off, the accumulator feeds the stored hydraulic fluid back through the ACC port to power the system components.

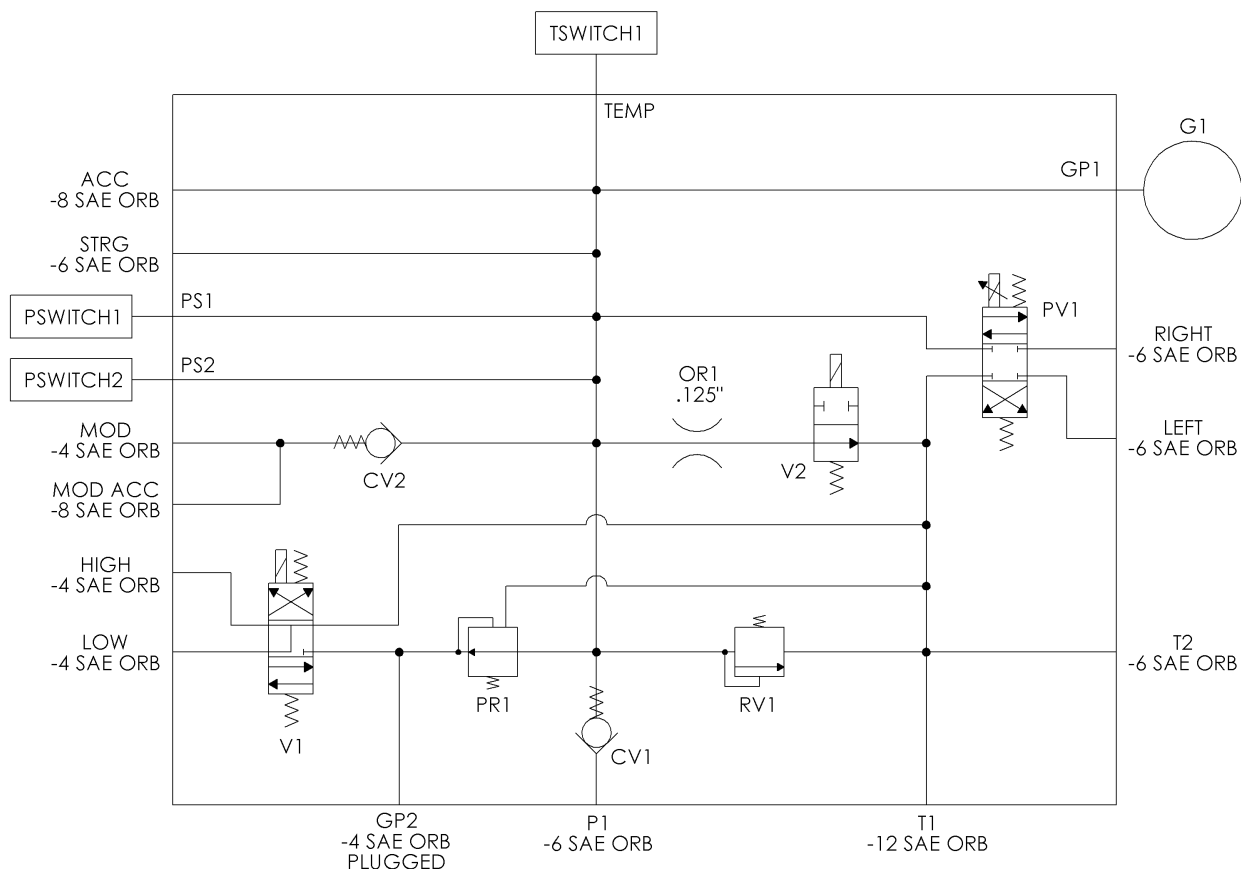

Hydraulic Manifold Schematic

Hydraulic Manifold Overview

PS1 and PS2

The low and high pressure switches are installed to these two ports. The switches monitor the manifold pressure to determine when the hydraulic pump should be running.

MOD and MOD ACC

The MOD and MOD ACC ports are joined together behind check valve CV2. The brake valve and brake accumulator connect to these two ports. The check valve ensures that the brake backup accumulator does not drain if the main system drains.

STRG

The STRG port provides hydraulic fluid to the front steering orbital.

GP1 and GP2

GP1 is a gage port. A needle gage is installed here from the factory. The gage provides feedback on the system pressure and assists in system troubleshooting.

GP2 is an optional gage port that allows monitoring of the reduced pressure output from PR1. By default the GP2 port is plugged from the factory.

PV1

The PV1 valve is a proportional flow valve. This valve provides fluid to the rear axle steering cylinder and is controlled by the VMC30.

PR1

The PR1 valve is a pressure reducing valve. It reduces system pressure to 250 psi (17 bar) for use by the shifting valve. The shift valve must operate at the lower pressure to prevent damage to the gearbox.

V1

The V1 valve controls gearbox shifting. The valve uses low-pressure fluid from the PR1 valve and directs it to either the low gear or high gear ports on the gearbox. The valve is controlled by the VMC30 and depends on operator input and controller logic.

T1

The T1 port is connected to the hydraulic reservoir tank through the hydraulic return filter.

V2

The V2 valve along with the OR1 orifice drains the main system accumulator at a controlled rate when the tractor is turned off. This provides additional safety for maintenance and operators.

Steering System Overview

The eTT tractor features a computer controlled four wheel steering system. The system operates in a slave/master configuration treating the front axle as the master and the rear axle as the slave. The process proceeds as follows:

- 1) The operator controls the front axle steering cylinder using the steering orbital. Note that the operator is in direct control of the front axle at all times.
- 2) The front and rear axle steer sensors send a variable voltage signal to the VMC30 controller.
- 3) The controller uses the two steer sensor inputs to send a variable voltage signal to the steering proportional valve in the hydraulic manifold.
- 4) The proportional valve provides hydraulic pressure to the rear axle steering cylinder, changing the position of the rear axle.

The hydraulic system fluid pressure is stored on-board in an accumulator. The accumulator allows the hydraulic pump to work on-demand, keeping battery drain to a minimum. Steering the front axle is possible after the truck has been shut down because the accumulator has stored hydraulic energy in it.

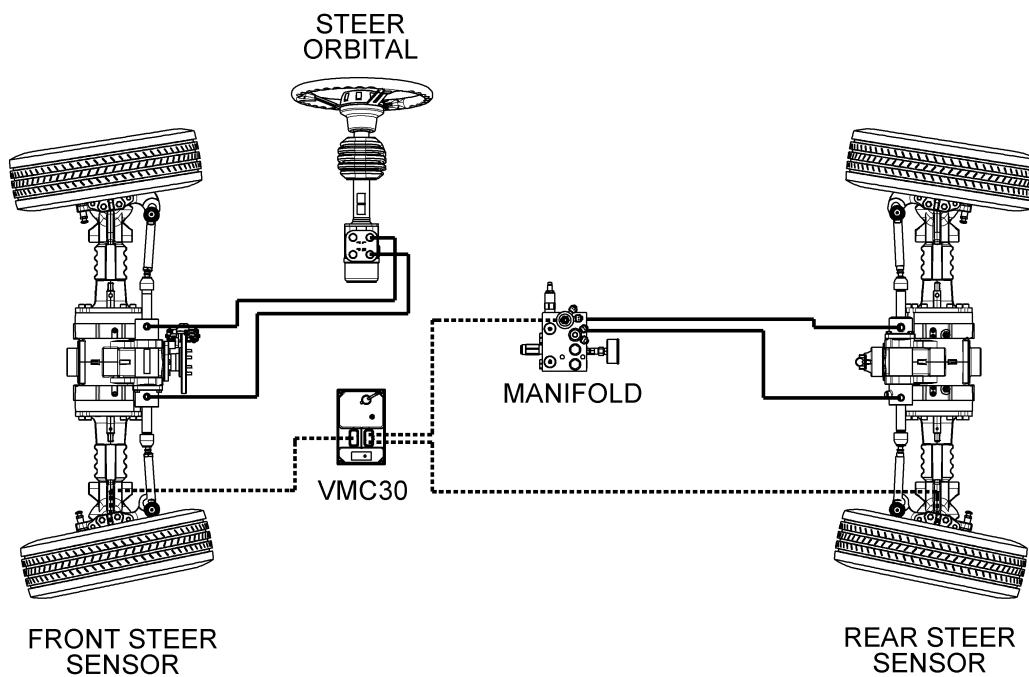

ETT8 / ETT12 / EXL16 FOUR WHEEL STEERING SYSTEM DIAGRAM

Steering Calibration Procedure

The eTT tractor steering has been calibrated at the factory to ensure that the front and rear steering coordinate properly. Should an axle be serviced or a steering sensor be serviced, it may be necessary to re-calibrate the four wheel steering system. Eagle has provided for calibration through the OPT10 digital display unit. Below are the instructions for performing this calibration.

1. Be familiar with usage of the OPT10 display, see section 13 of this manual for some basic instructions.
2. Have a long straightedge and a paper and pencil/pen handy before starting the calibration procedure.
3. Using the reference instructions from section 13 of this manual, enter the diagnostic menu and then the *1 INPUT DIAGNOSTICS* submenu. Scroll up/down to the *FRONT STEER COUNTS* variable.
4. Monitor the *FRONT STEER COUNTS* variable while steering the steering wheel full right (to the axle stops) and full left (to the axle stops). Note these two values for later usage.
5. Using the straightedge, center the front axle right-to-left. See the diagram below for reference. Note the value for *FRONT STEER COUNTS* for later usage.

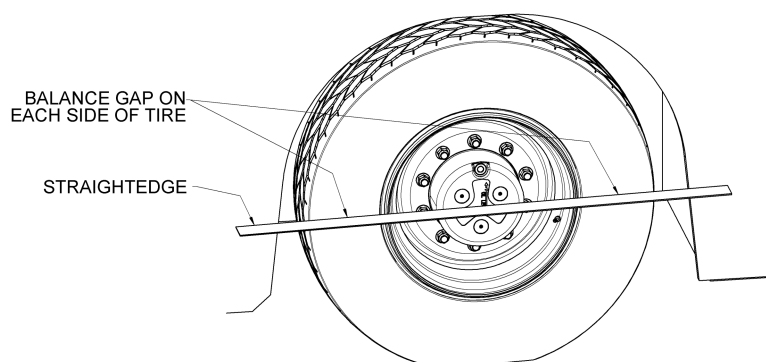

6. Back out of the *1 INPUT DIAGNOSTICS* menu and then enter the *5 STEER SETUP* menu.
7. Scroll up/down to the *FRONT CENTER CTS* variable and then press the 4 (right) button to edit the variable.
8. Modify the *FRONT CENTER CTS* variable to match the front axle center value you noted above. Use the 3 (left) and 4 (right) buttons to select the necessary digit and then use the 1 (up) and 2 (down) buttons to increase or decrease the value of the digit. When the variable is correctly set, press the * (star) button to save the variable.
9. Modify the *FRONT MAX LEFT CTS* and *FRONT MAX RIGHT CTS* in a similar fashion to match the values you noted while steering the front axle up against the stops.
10. Modify the rear axle values per the below. This is a temporary setting that will assist in getting full travel from the rear axle.

REAR CENTER CTS = 225
REAR MAX LEFT CTS = 50
REAR MAX RIGHT CTS = 350

11. After modifying the six variables, scroll down to *STORE STRNG PARAMS*. Set this value to 1 and then press * (star) to save. This will lock-in the six steering variable modifications and save them to the controller memory.
12. Turn the tractor off, wait 5 seconds, and then turn the tractor back on to start with the new variables active.
13. With the tractor back on, enter the diagnostic menu and look at the *REAR STEER COUNTS* input. Record the center steering value for the rear axle using the straight edge. Record the max left (steering wheel left) and right positions as well. The rear axle should steer up against the steering stops with full travel of the front axle.
14. Re-enter the *5 STEER SETUP* menu and enter the recorded values for *REAR CENTER CTS*, *REAR MAX LEFT CTS*, and *REAR MAX RIGHT CTS*. Set the *STORE STRNG PARAMS* variable to 1 to save the changes.
15. Turn the tractor off, wait 5 seconds, then turn the tractor back on to start with the new variables active. You have now completed the steering calibration process.

Regenerative Braking Tuning Instructions

The eTT tractor features regenerative braking. This feature converts tractor motion to electrical energy which is then used to put a small amount of charge back into the battery. The regenerative braking slows the tractor at a rate proportional to the amount of electrical energy removed. The amount of braking is controlled by the VMC30 and can be configured using the OPT10 display panel*.

There are four parameters that are adjustable using the OPT10. Neutral brake is the regenerative brake setting used when the operator removes their foot from the accelerator pedal or when the selected direction (fwd/rev) is changed. Pedal brake is the amount of regenerative braking that is applied to assist the hydraulic brakes when the brake pedal is pressed. Low/Tow and High gear have separate brake settings to allow different behaviors when towing or when traveling unloaded.

The regenerative braking settings can be set anywhere between 5 and 35 for neutral brake and between 10 and 35 for pedal brake. This range can provide anywhere from a negligible brake effect to very significant self braking. The factory settings are as follows.

NEUTRAL BRAKE LOW - 6
NEUTRAL BRAKE HIGH - 15
PEDAL BRAKE LOW - 15
PEDAL BRAKE HIGH - 30

To modify the braking parameters, follow the below instructions.

1. Be familiar with usage of the OPT10 display, see section 13 of this manual for some basic instructions.
2. Using the reference instructions from section 13 of this manual, enter the diagnostic menu and then the 6 *REGEN SETUP* submenu.
3. Scroll up/down to the desired regenerative braking variable and then press the 4 (right) button to edit the variable.
4. Modify the variable to the desired setting. Use the 3 (left) and 4 (right) buttons to select the necessary digit and then use the 1 (up) and 2 (down) buttons to increase or decrease the value of the digit. When the variable is correctly set, press the * (star) button to save the variable. Note that these settings will be put into effect immediately on the tractor, but will reset on key off. In order to save permanently you must also complete step 5.
5. After modifying the desired regenerative braking variables, scroll down to *STORE REGEN PARAMS*. Set this value to 1 and then press * (star) to save. This will lock-in the modifications and save them to the controller memory.

*Note that only units manufactured January 2014 and later have the option for field modification of the regenerative braking parameters.

Revision Log

Rev	Date	Description	Appr.
A	25-Feb-2014	Original release for production	PRB
B	12-Feb-2015	Added revision G manifold schematic and information	PRB
C	6-Jun-2016	Changed eXL16 model name to eTT16	TFP

This page intentionally left blank.

Table of Contents

Appendix B - Battery Care	
Description	Page
Battery Basics	B-2
Charger Basics	B-3
Battery Care	B-4
Cold Weather Battery Usage	B-5
Revision Log	B-8

Battery Basics

Eagle Tugs is not a battery nor charger manufacturer, but Eagle may recommend certain brands and models. The below information applies regardless of what brand and model traction battery or charger is on the truck.

Battery Basics

The eTT traction battery is a heavy duty industrial battery designed specifically for electrical vehicle usage. The battery is a collection of 40 individually sealed cells combined into a single heavy gage steel tray. The battery provides the motive power for the eTT as well as providing necessary ballast weight.

The individual battery cells consist of lead plates separated from each other by porous mats. The lead plates are immersed in a sulfuric acid solution. Discharging and charging the battery causes chemical reactions between the lead plates and the sulfuric acid. This chemical process is repeatable and provides the basis for continued charge and discharge cycles.

Batteries produce both voltage and amperage. Voltage is the measure of electrical potential and can be thought of analogously as the fluid “pressure” in the electrical system. Amperage is the quantity of current flow and is likewise analogous to fluid “flow”. Both voltage and amperage work together to do work in the battery system. The product of voltage and amperage is watts.

Each battery cell produces a nominal voltage of 2.0 volts. The actual voltage ranges from 2.15 volts when fully charged, to 1.97 volts when completely discharged. The cells are wired in series which causes the voltage to add from each cell. The 40 cells at 2.0 volts per cell creates an 80V nominal battery.

Batteries are rated in ampere-hours. An ampere hour is the amount of amps (current) a battery can supply in a given amount of time. Most batteries are rated at a 6-hour discharge, meaning that the current output is spread over a 6-hour period of time. The ampere hour rating along with the battery voltage determine the total amount of energy a battery can store.

To measure the current state of charge of a battery cell, the most accurate method is by using specific gravity. The acid solution in the battery varies greatly by charge level. A fully charged battery will have a very strongly acidic electrolyte. In a fully discharged battery the acid solution is very weak. This has to do with the sulfuric acid in the solution being absorbed into the lead plates during discharge. Sulfuric acid and water have different densities, so an accurate measure of the density (specific gravity) of the electrolyte will tell you the percentage of acid present in the electrolyte. The specific gravity reading can be measured with a hydrometer and should be compared to a chart provided by the battery manufacturer to accurately determine state of charge.

The battery electrolyte loses water over time to both evaporation and electrolysis (breaking up of water into hydrogen and oxygen through an applied electric current). The electrolysis happens naturally as part of the charging cycle. Water has to be re-introduced into the battery to account for the water loss. Each cell should be topped off regularly to prevent a low electrolyte situation. Low electrolyte in the battery will lead to reduced power output and can damage the cells.

To ensure that all 40 individual cells are working at the same level, an equalization charge is periodically required. The equalization charge is essentially a controlled overcharge. It ensures that all cells are at their absolute maximum capacity. Battery water levels should be corrected immediately after equalization. The equalization charge will have heated the electrolyte, causing it to expand and be at its highest level. If you water a cold battery and then equalize, the electrolyte will overflow, spilling acid on the ground.

Charger Basics

Charger Basics

The purpose of the charger is to use electrical power to reverse the chemical reaction in the battery and return it to a charged state.

During the charge process the lead plates in the battery reverse their chemical change and the electrolyte acid becomes more concentrated. The specific gravity will also change, reflecting the change in acid concentration.

Eagle only recommends the use of smart chargers with eTT batteries. Smart chargers communicate with a battery monitoring module installed to the battery. This module informs the charger of voltage and temperature of the battery to prevent overcharging and extend the life of the battery.

The charge cycle starts out at a high amperage, up to 23 amps per 100 ampere hours of battery capacity. As the battery charge state rises, the charge amperage will slowly taper off to 5 amps per 100 ampere hours of battery capacity until the battery reaches a full charge.

An equalization charge will hold the final charge amperage of 5 amps per 100 ampere hours for approximately three hours past full charge. This provides an opportunity for all cells to reach their absolute maximum charge levels. The equalization phase of charging will also cause degassing of the electrolyte through electrolysis. The bubbles created during degassing are beneficial to the battery. The bubbles stir the electrolyte and prevent concentrated acid from settling to the bottom of the battery cells.

Batteries produce heat when discharged and charged. During charging the battery temperature can rise significantly to the point of damaging the battery. The battery should never exceed 115°F/46°C at any time. A smart charger monitors the temperature and will cut back on charging amperage should the battery temperature approach the 115°F/46°C limit.

The eTT tractor line features a Burton style charge connector on the side of the tractor. This connector is where you plug the charger into the tractor. A small switch located in the charge connector will prevent tractor drive-off when the charger is plugged in.

Battery Care

The flooded lead acid batteries used in the eTT series tractors are not maintenance free. The battery must be regularly maintained to ensure safe operation and battery longevity.

Battery Watering

Flooded lead acid batteries lose water during charging and regular usage. This lost water **MUST** be regularly added back to the battery to maintain electrolyte levels. It is the responsibility of the customer to maintain battery water levels.

Water should never be added to the battery before charging. Watering a battery prior to charging can cause the electrolyte to overflow and spill onto the ground. Batteries should be watered as soon as possible **AFTER** completing a charge and/or equalization cycle.

When watering batteries with the single point watering system, it is important to stop filling as soon as the water flow indicator stops spinning (or nearly stops). This will prevent overwatering.

Equalization Charging

The battery must be equalize charged every 1-4 weeks depending on tractor usage. Smart chargers sold by Eagle including the Posicharge SVS/DVS and the Ametek UltraCharge/UltraMaxx series will automatically attempt to equalize charge the battery on a pre-set schedule.

It is the responsibility of the customer to ensure that equalization charges are scheduled (for chargers without automatic scheduling), and allowed to complete. For tractors with high duty cycles (20+ hrs/wk) the batteries should be equalized weekly.

Battery Cleaning

The top of the battery should be regularly cleaned to prevent build up of dirt and debris. Spray an acid neutralizing solution (baking soda in water or similar) on the top of the battery and gently wash off with clean water. Failure to regularly clean the battery can result in voltage leakage and/or a fire hazard.

Battery Discharge

The eTT series of tractors is programmed to enter a limp functionality when the battery reaches a 30% state of charge. Eagle recommends charging the battery at all available opportunities to maintain battery state of charge well above this cutoff value.

When the tractor enter limp mode, the battery should be charged immediately. Continued usage of the tractor can drop the state of charge below 20% which will cause damage to the battery.

Never store a tractor/battery in a fully discharged state. This will lead to battery damage.

Cold Weather Battery Usage

There are two issues that batteries face in extremely cold weather; Reduced Capacity and Freezing Electrolyte.

Reduced Capacity

As the battery temperature drops, the internal resistance of the battery increases and the usable capacity is decreased. At a battery temperature of -10°F / -23°C , the battery can only deliver roughly 50% of the rated capacity. At higher loads, the usable capacity is reduced even further. During a tow event, the eTT tractor can demand large amounts of current from the battery. A battery cold-soaked to a low temperature may not be able to maintain voltage at the required current, leading to error messages and an inability to tow the load.

See the below chart for a general idea of the temperature effect on capacity.

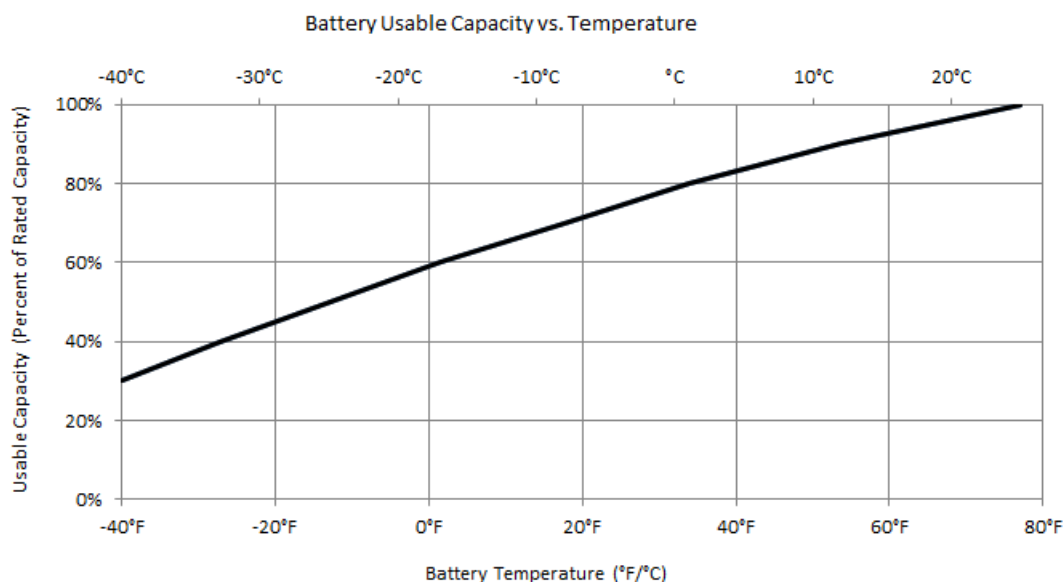

There are a few ways to ensure that the tractor will be able to perform in cold weather.

1. When leaving a tractor/battery in cold weather for long periods, ensure that the battery is fully charged. This will ensure the maximum possible capacity during cold operation, and will also prevent possible electrolyte freezing (see next page).
2. The battery will produce heat internally during normal usage. Because of this behavior, a battery stored in a climate controlled environment will be usable in a non-climate controlled environment without degradation of performance. The battery will maintain the internal temperature while in use.
3. The battery is heated during a charge cycle. This can warm or maintain battery temperature even if the battery is being charged in a cold environment.

This page intentionally left blank

Cold Weather Battery Usage (Continued)

Electrolyte Freezing

The electrolyte in the eTT traction battery is a weak sulfuric acid solution. As the battery is discharged, the acid is absorbed by the battery plates and the electrolyte becomes weaker turning into mostly water. A deeply discharged battery will readily freeze in cold weather. If the electrolyte freezes it can damage or destroy the battery.

It is very important that any tractor/battery stored in cold weather be stored with a fully charged battery. This will eliminate the danger of freezing. Refer to the below chart as a reference for state of charge versus freezing temperature.

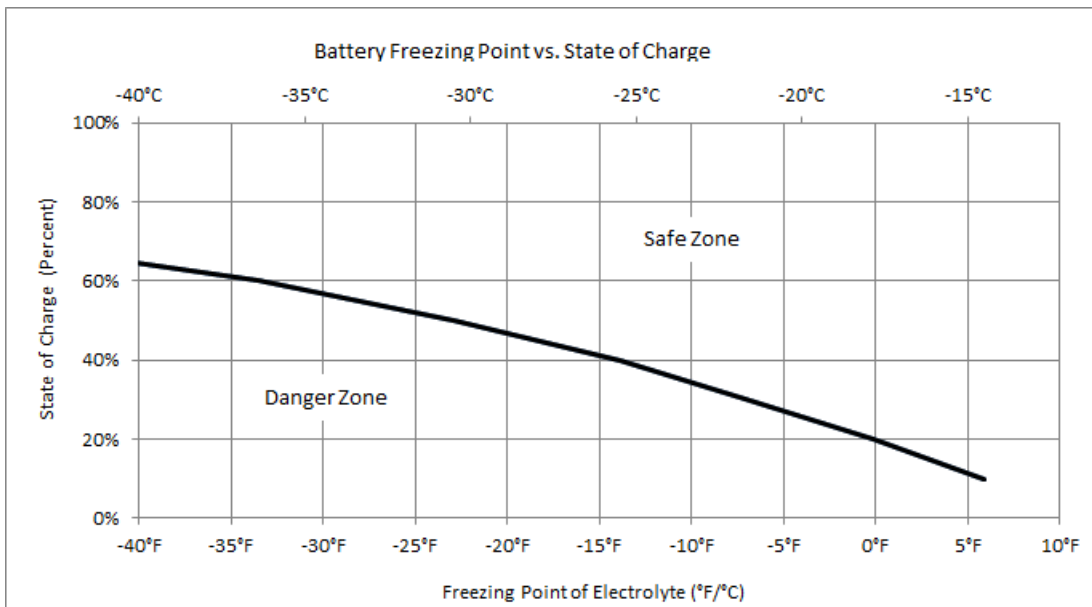

Revision Log

Rev	Date	Description	Appr.
A	25-Feb-2014	Original release for production	PRB
B	6-Jun-2016	Changed eXL16 model name to eTT16, added battery care information	PRB

Table of Contents

Appendix C - Axles	
Description	Page
Axle Service Procedure	C-2
Brake Disc Inspection	C-3
Toe-in and Toe-out Adjustment	C-4
Steer Angle Adjustment	C-5
Axle Housing - Front Axle	C-6
Bevel Gear Set - Front Axle	C-7
Brake Caliper - Front Axle	C-8
Axle Housing - Rear Axle	C-9
Bevel Gear Set - Rear Axle	C-10
Potentiometer - Front and Rear Axle	C-11
Swivel Housings and Steer Cylinder - Front and Rear Axle	C-12
Differential - Front and Rear Axle	C-13
Double U-Joint - Front and Rear Axle	C-14
Brakes - Front and Rear Axle	C-15
Wheel Hub - Front and Rear Axle	C-16
Final Reduction - Front and Rear Axle	C-17
Revision Log	C-18

Axle Service Procedure

Tractors Under Warranty

For servicing of axles installed in tractors under warranty, please contact Eagle Tugs at 800.671.0431. Eagle Tugs will work with Carraro to determine the best servicing procedure.

Tractors Out of Warranty

If your tractor is no longer under warranty coverage, Eagle Tugs highly recommends working with your local Carraro certified service provider. Carraro has a large worldwide network of dealers and service providers. A local servicer can be found at <http://www.carry4you.it>.

Parts Sales

Eagle has provided in this manual a list of the most common axle components that may need replacement. Contact Eagle Tugs Parts Sales at parts@eagletugs.com or 800.671.0431 to order any of these parts or any additional unlisted parts.

Service Work

It is highly recommended that all axle service be performed only by a Carraro certified service provider. Proper servicing and parts replacement requires special tools and procedures. Failure to follow proper service procedures can cause damage to the axles and void the axle warranty.

Brake Disc Inspection

The eTT tractor is equipped with immersed wet disk brakes. The brakes should be checked for wear according to the preventive maintenance schedule. Wear is determined by measuring the thickness of both the friction plates and the separator plates. When the plates are below the allowable threshold, the plates need to be replaced.

Below is a diagram of the plate layout in the axle (2 places per axle) as well as the replacement criteria. Note that all friction plates and separator discs should be replaced at the same time. This replacement procedure requires some disassembly of the axle and should only be performed by a Carraro approved service provider.

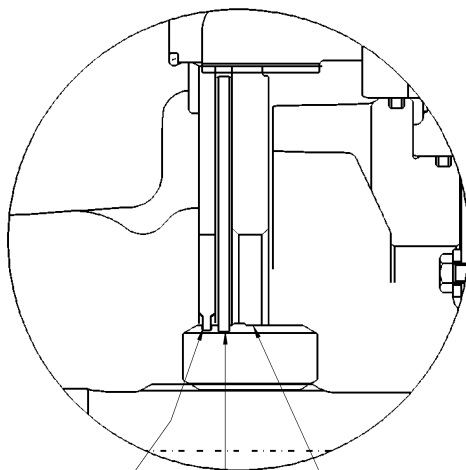
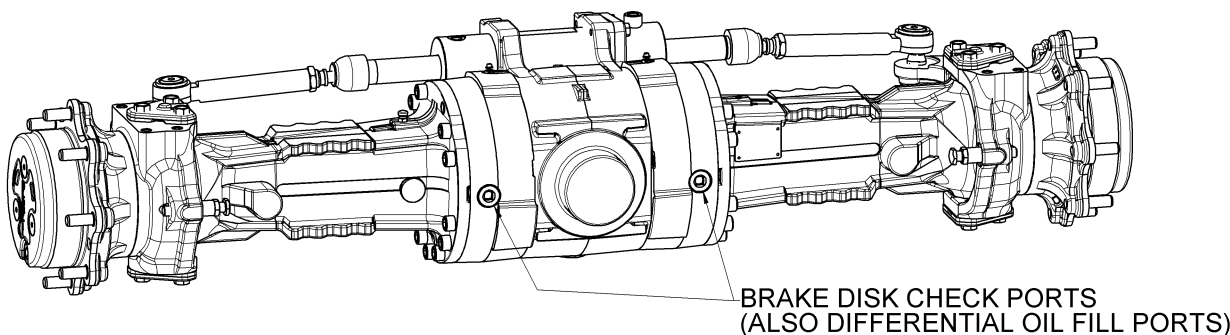

SEPARATOR PLATE (SMALL) - 1 PLCS
 NEW PLATE THICKNESS: .197"±.002 (5.0mm±.05)

SEPARATOR PLATE (LARGE)
 NEW PLATE THICKNESS: .352"±.002 (8.95mm±.05)
 MINIMUM WORN THICKNESS: .346" (8.8mm)

FRICTION PLATE - 1 PLCS
 NEW PLATE THICKNESS: .189"±.002 (4.8mm±.05)
 MINIMUM WORN THICKNESS: .157" (4.0mm)

Toe-in and Toe-out Adjustment

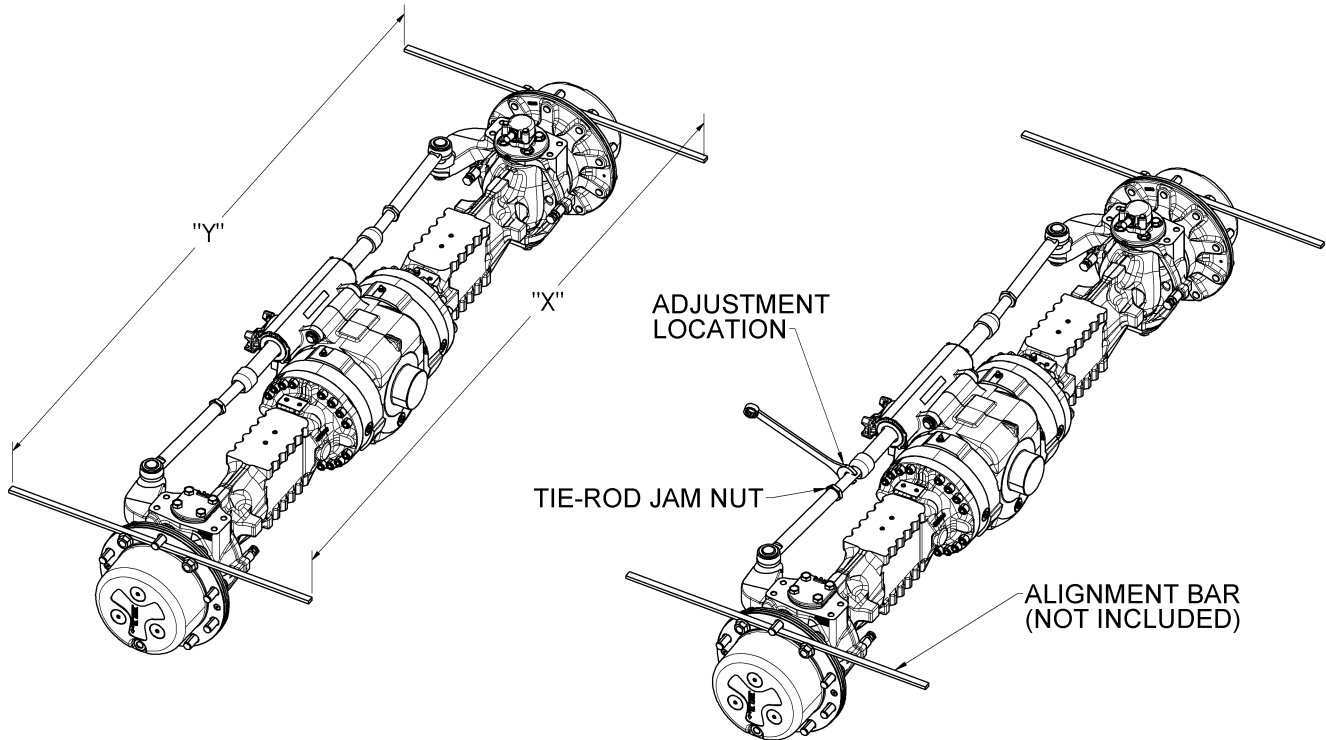

The toe adjustment on the eTT axles was set at the factory. Should a tire-rod ever need to be replaced or should the tractor exhibit abnormal tire wear, the toe may need to be adjusted. To perform an adjustment, follow the below procedure.

- 1) Put two equal length bars (approx. 3' or 1m long) on the ends of the axle. Lock them in place with nuts on the wheel studs. Ensure that they are centered on the wheel hub and are horizontal.
- 2) Measure dimensions "X" and "Y" as illustrated above. The two dimensions should be the same (0° toe).
- 3) If the dimensions are not equal, loosen the tie-rod jam nuts and adjust the tie-rod length.
- 4) When the "X" and "Y" dimensions are equal, secure the jam nuts and remove the alignment bars.

Steer Angle Adjustment

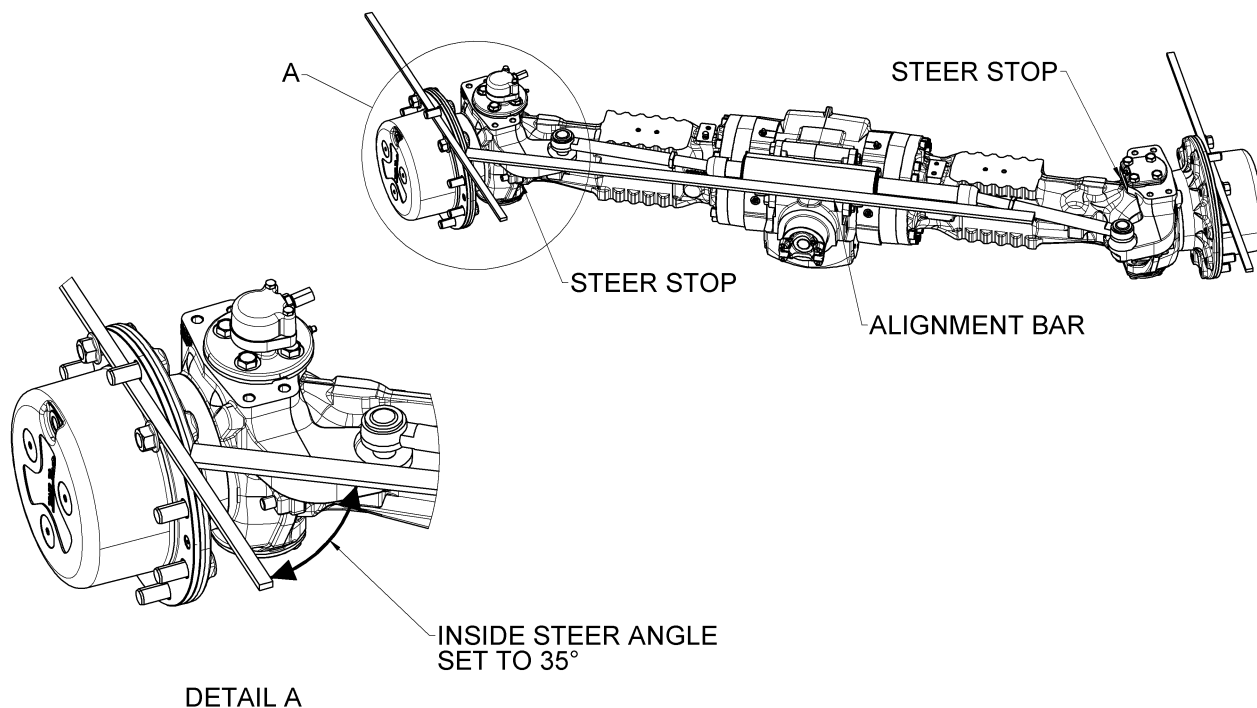

The steering stops on the eTT axles were set at the factory and should not need to be adjusted. Should adjustment ever be necessary however, follow the below procedure.

- 1) Put two equal length bars (approx. 3' or 1m long) on the ends of the axle. Lock them in place with nuts on the wheel studs. Ensure that they are centered on the wheel hub and are horizontal.
- 2) Hold a third bar (approx. 6' or 2m long) tight against the steering cylinder or other flat surface along the axle length.
- 3) Set the inside steering angles as shown above to 35 degrees.
- 4) Adjust and tighten all four steering stops (two for LH steer and two for RH steer). The steering stops should rest against the bosses on the axle trumpet castings.

Axle Housing - Front Axle

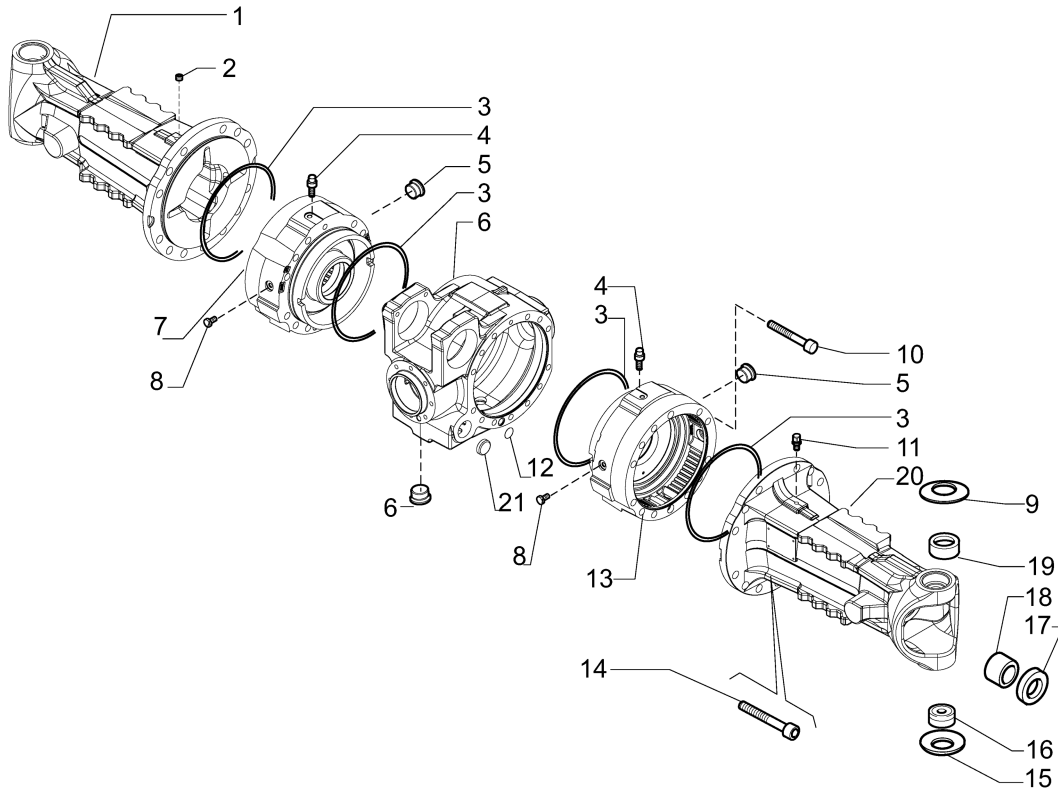

Item	Part Number	Qty.	Description
1	A-ES12-392131	1	TRUMPET
2	A-ES12-021558	1	PLUG M10X1
3	A-ES12-028562	4	O-RING
4	A-ES12-116792	2	BREATHER M10X1
5	A-ES12-125280	3	PLUG M30X2
6	A-ES12-141210	1	CENTRAL BODY
7	A-ES12-140330	1	LH BRAKE CYLINDER
8	A-ES12-030740	4	PLUG
9	A-ES12-128633	2	BELLEVILLE WASHER
10	A-ES12-021334	2	SCREW M12X110
11	A-ES12-104988	1	BREATHER M10X1
12	A-ES12-028111	2	O-RING
13	A-ES12-140329	1	RH BRAKE CYLINDER
14	A-ES12-021364	24	SCREW M16X150
15	A-ES12-128630	2	BELLEVILLE WASHER
16	A-ES12-045161	2	SPHERICAL JOINT
17	A-ES12-139101	2	SEAL
18	A-ES12-118547	2	BUSHING
19	A-ES12-143563	2	BUSHING
20	A-ES12-145533	1	TRUMPET
21	A-ES12-130667	2	PLUG

Bevel Gear Set - Front Axle

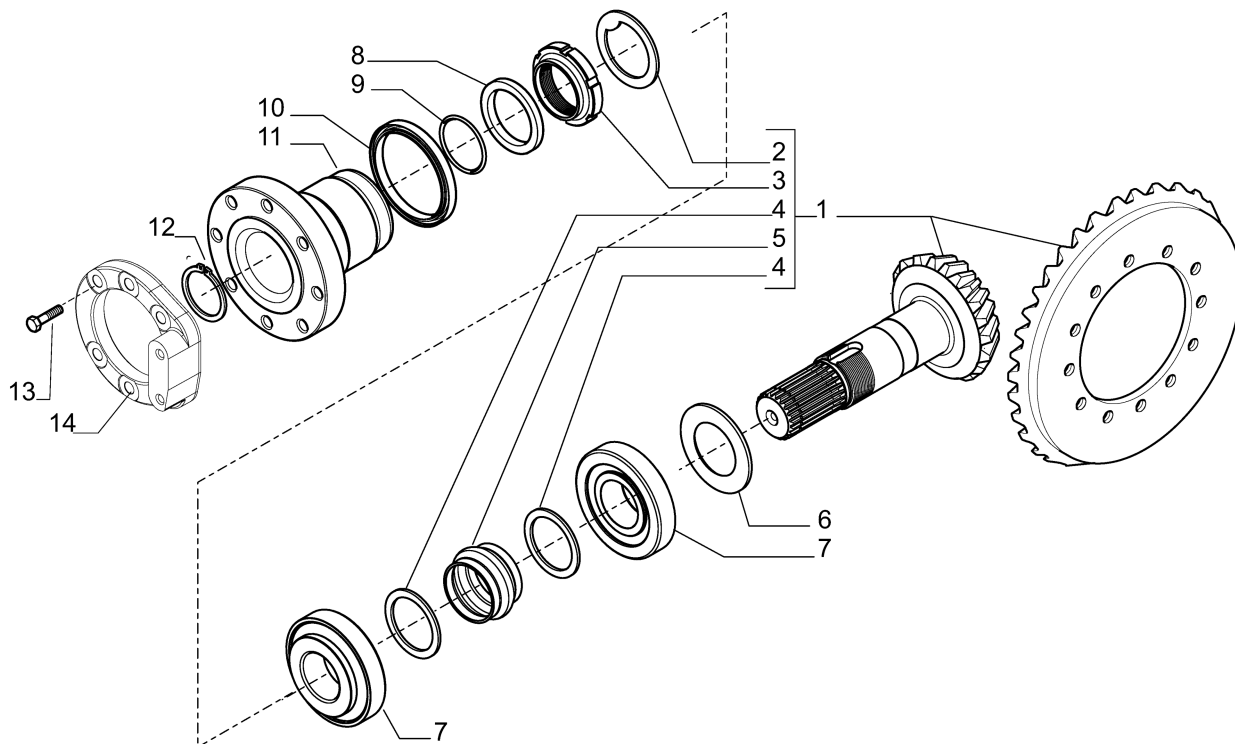

Item	Part Number	Qty.	Description
1	A-ES12-068401	1	BEVEL GEAR SET 11/32 (INCLUDES ITEMS 2-5)
2	A-ES12-113717	1	LOCK WASHER
3	A-ES12-115054	1	RING NUT M40X1.5
4	A-ES12-125829	2	WASHER
5	A-ES12-125806	1	COLLAPSIBLE WASHER
6	A-ES12-132265	-	SHIM 2.50 MM
6	A-ES12-132266	-	SHIM 2.60 MM
6	A-ES12-132267	-	SHIM 2.70 MM
6	A-ES12-132268	-	SHIM 2.80 MM
6	A-ES12-132269	-	SHIM 2.90 MM
6	A-ES12-132270	-	SHIM 3.00 MM
6	A-ES12-132271	-	SHIM 3.10 MM
6	A-ES12-132272	-	SHIM 3.20 MM
6	A-ES12-132273	-	SHIM 3.30 MM
6	A-ES12-132274	-	SHIM 3.40 MM
7	A-ES12-027350	2	BEARING
8	A-ES12-123402	1	WASHER
9	A-ES12-028532	1	O-RING
10	A-ES12-145050	1	SEAL RING
11	A-ES12-149032	1	FLANGE
12	A-ES12-024789	1	SNAP RING D34
13	A-ES12-020921	6	SCREW M12X35
14	A-ES12-149031	1	BRAKE CALIPER SUPPORT

Brake Caliper - Front Axle

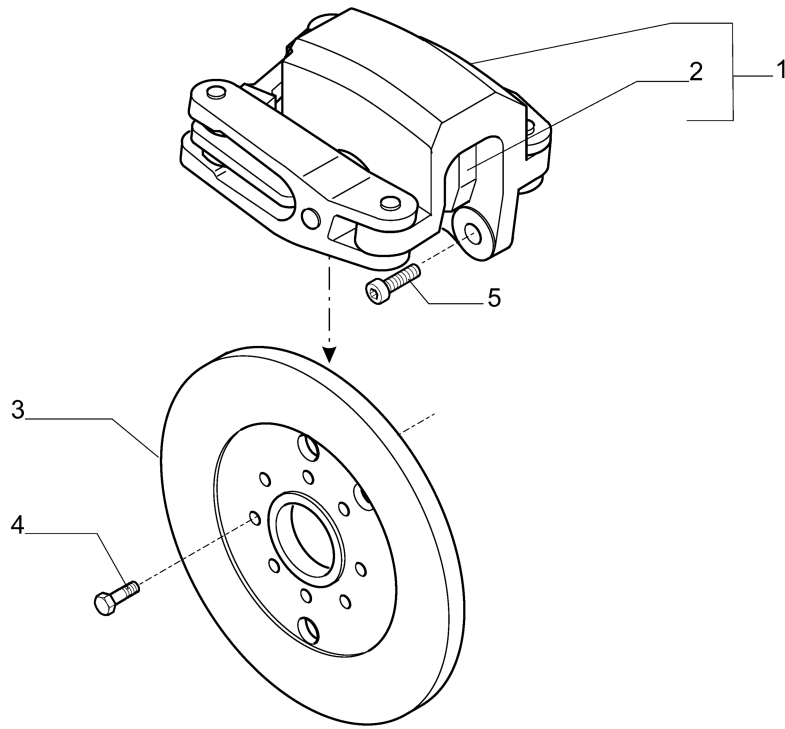

Item	Part Number	Qty.	Description
1	A-ES12-148947	1	BRAKE CALIPER (INCLUDES ITEM 2)
2	A-ES12-049479	1	LINING KIT
3	A-ES12-149033	1	BRAKE DISC
4	A-ES12-020851	1	BOLT M10X25
5	A-ES12-021408	2	BOLT M10X30

Axle Housing - Rear Axle

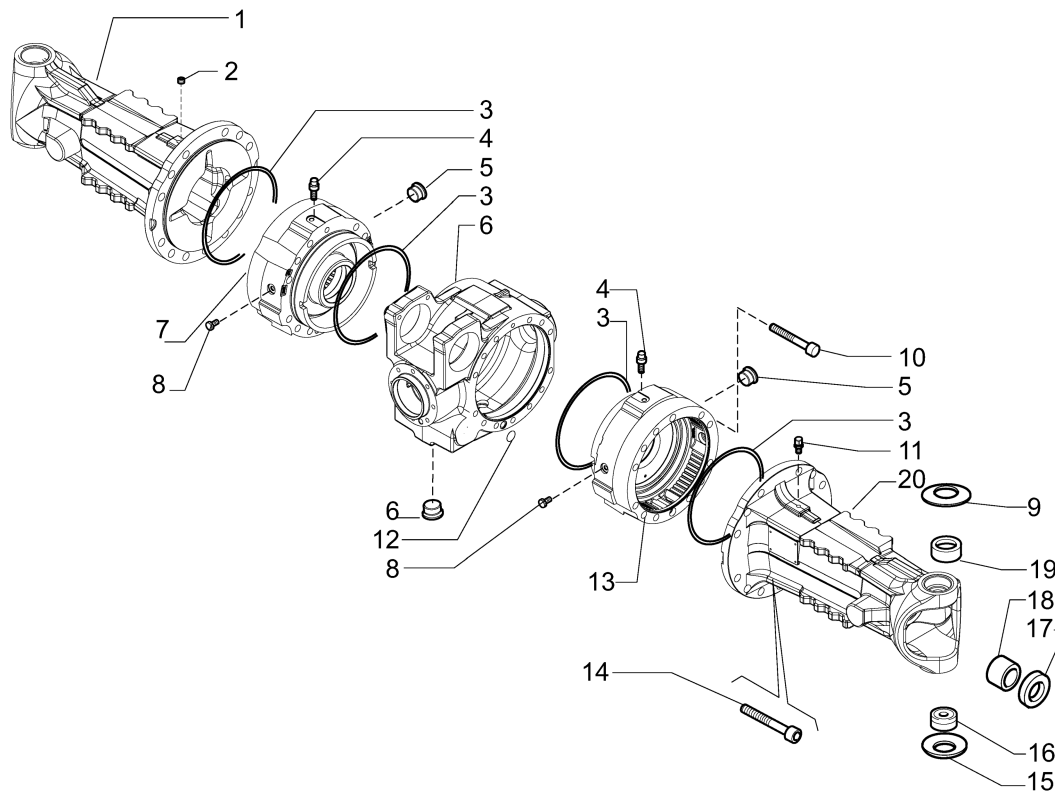

Item	Part Number	Qty.	Description
1	A-ES12-145533	1	TRUMPET
2	A-ES12-021558	1	PLUG M10X1
3	A-ES12-028562	4	O-RING
4	A-ES12-116792	2	BREATHER M10X1
5	A-ES12-125280	3	PLUG M30X2
6	A-ES12-641263	1	CENTRAL BODY
7	A-ES12-140330	1	LH BRAKE CYLINDER
8	A-ES12-030740	4	PLUG
9	A-ES12-128633	2	BELLEVILLE WASHER
10	A-ES12-021334	2	SCREW M12X110
11	A-ES12-104988	1	BREATHER M10X1
12	A-ES12-028111	2	O-RING
13	A-ES12-140329	1	RH BRAKE CYLINDER
14	A-ES12-021364	24	SCREW M16X150
15	A-ES12-128630	2	BELLEVILLE WASHER
16	A-ES12-045161	2	SPHERICAL JOINT
17	A-ES12-139101	2	SEAL
18	A-ES12-118547	2	BUSHING
19	A-ES12-143563	2	BUSHING
20	A-ES12-392131	1	TRUMPET

Bevel Gear Set - Rear Axle

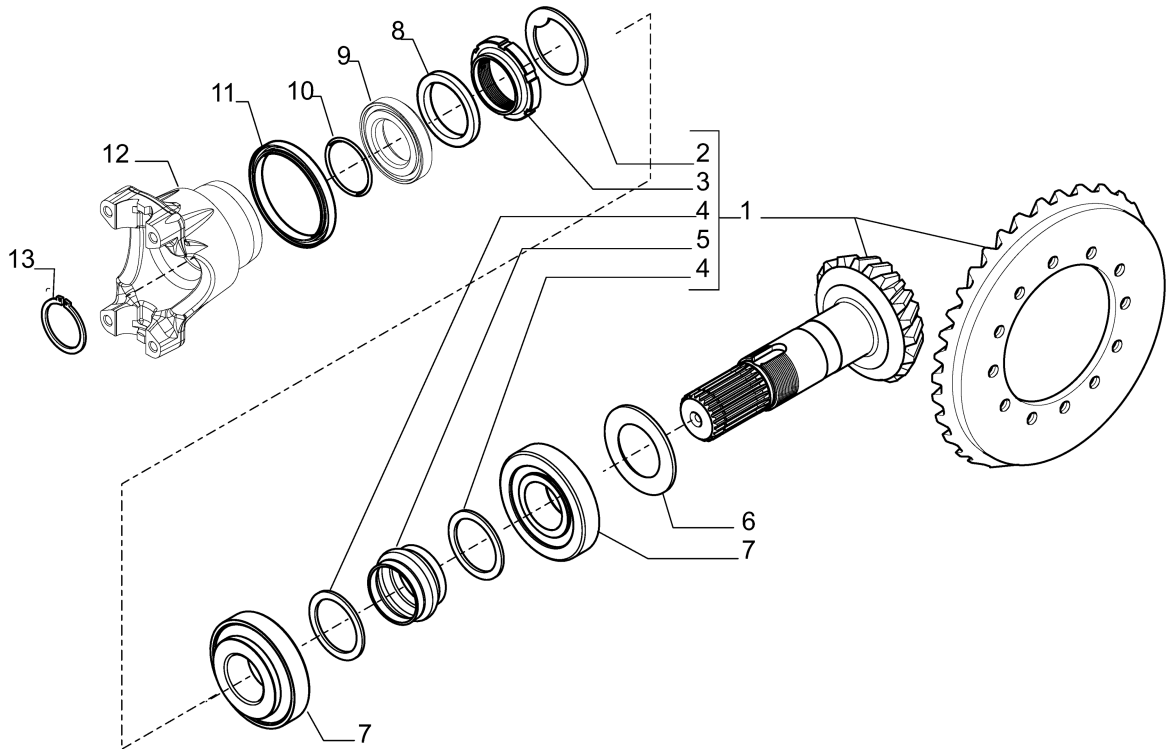

Item	Part Number	Qty.	Description
1	A-ES12-065598	1	BEVEL GEAR SET 11/32 (INCLUDES ITEMS 2-5)
2	A-ES12-113717	1	LOCK WASHER
3	A-ES12-115054	1	RING NUT M40X1.5
4	A-ES12-125829	2	WASHER
5	A-ES12-125806	1	COLLAPSIBLE SPACER
6	A-ES12-132265	-	SHIM 2.50 MM
6	A-ES12-132266	-	SHIM 2.60 MM
6	A-ES12-132267	-	SHIM 2.70 MM
6	A-ES12-132268	-	SHIM 2.80 MM
6	A-ES12-132269	-	SHIM 2.90 MM
6	A-ES12-132270	-	SHIM 3.00 MM
6	A-ES12-132271	-	SHIM 3.10 MM
6	A-ES12-132272	-	SHIM 3.20 MM
6	A-ES12-132273	-	SHIM 3.30 MM
6	A-ES12-132274	-	SHIM 3.40 MM
7	A-ES12-027350	2	BEARING
8	A-ES12-123402	1	WASHER
9	A-ES12-137517	1	SPACER
10	A-ES12-028532	1	O-RING
11	A-ES12-145050	1	SEAL RING
12	A-ES12-137959	1	FLANGE
13	A-ES12-024789	1	SNAP RING D34

Potentiometer - Front and Rear Axle

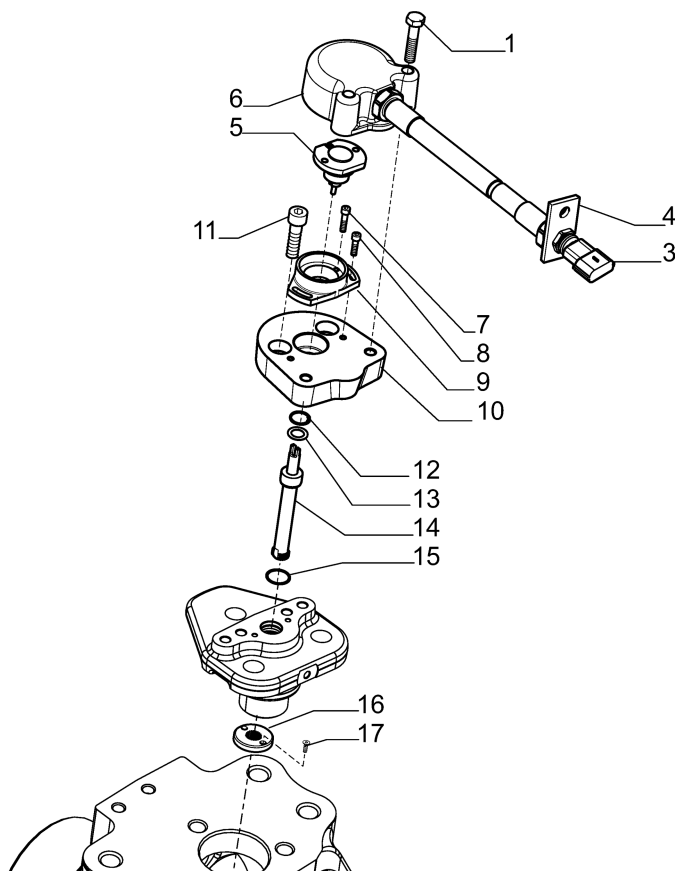

Item	Part Number	Qty.	Description
1	A-ES12-020798	2	BOLT M8X50
2	A-ES12-643375	1	POTENTIOMETER CABLE KIT (INCLUDES ITEMS 3 THRU 6)
3	A-ES12-130608	1	CONNECTOR
4	A-ES12-131283	1	PLATE
5	A-ES12-643377	1	SENSOR
6	A-ES12-643334	1	COVER
7	A-ES12-021356	2	BOLT M4X20
8	A-ES12-021354	2	BOLT M4X12
9	A-ES12-643345	1	PLATE
10	A-ES12-339889	1	POTENTIOMETER SUPPORT
11	A-ES12-021391	2	BOLT M8X20
12	A-ES12-024859	1	SNAP RING
13	A-ES12-023122	1	WASHER
14	A-ES12-339890	1	PIN
15	A-ES12-028111	1	O-RING
16	A-ES12-136669	1	WASHER
17	A-ES12-020480	2	BOLT M4X10

Swivel Housings and Steer Cylinder - Front and Rear Axle

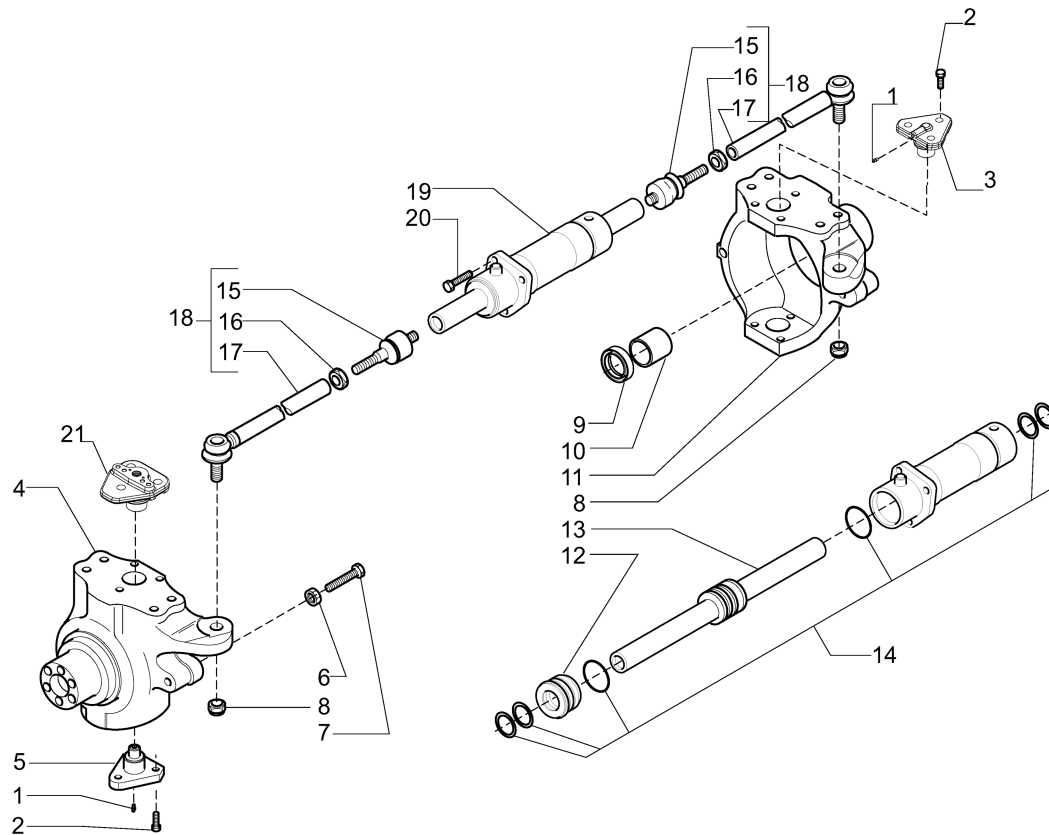

Item	Part Number	Qty.	Description
1	A-ES12-024210	3	GREASE FITTING M6X1
2	A-ES12-126922	12	SCREW M14X35
3	A-ES12-128880	1	KINGPIN
4	A-ES12-145015	1	LH SWIVEL HOUSING
5	A-ES12-128881	2	KINGPIN
6	A-ES12-022129	4	NUT M16
7	A-ES12-124748	4	SCREW M16X100
8	A-ES12-022431	2	NUT M20X1.5
9	A-ES12-144485	2	SEAL
10	A-ES12-125390	2	BUSHING
11	A-ES12-145016	1	RH SWIVEL HOUSING
12	A-ES12-049138	1	CYLINDER HEAD
13	A-ES12-048844	1	ROD
14	A-ES12-048845	1	SEAL KIT
15	A-ES12-049013	2	BALL JOINT
16	A-ES12-070787	2	NUT M24X1.5
17	A-ES12-350969	2	TIE ROD
18	A-ES12-131808	2	STEERING ARM (INCLUDES ITEMS 15-17)
19	A-ES12-641448	1	STEERING CYLINDER (INCLUDES ITEMS 12-14)
20	A-ES12-128534	3	SCREW M12X45
21	A-ES12-136667	1	KINGPIN

Differential - Front and Rear Axle

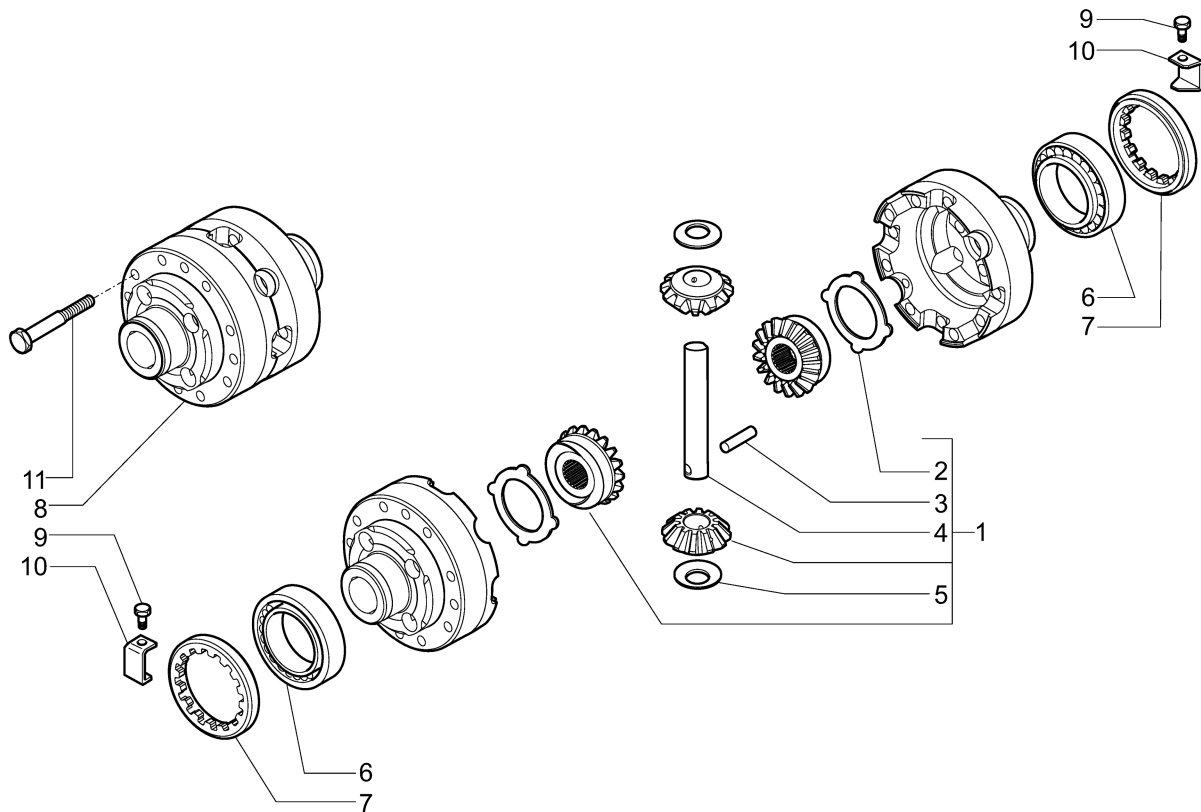

Item	Part Number	Qty.	Description
1	A-ES12-066161	1	DIFFERENTIAL KIT (INCLUDES ITEMS 2-5)
2	A-ES12-120361	2	DRIVE PLATE
3	A-ES12-116451	1	PIN D7X40
4	A-ES12-115731	1	SHAFT
5	A-ES12-115730	2	THRUST WASHER
6	A-ES12-027309	2	BEARING
7	A-ES12-107400	2	RING NUT
8	A-ES12-137972	1	DIFFERENTIAL HOUSING
9	A-ES12-128440	2	BOLT M6X10
10	A-ES12-136156	2	LOCKING PLATE
11	A-ES12-125552	12	BOLT M10X1.5X75 (SELF LOCKING)

Double U-Joint - Front and Rear Axle

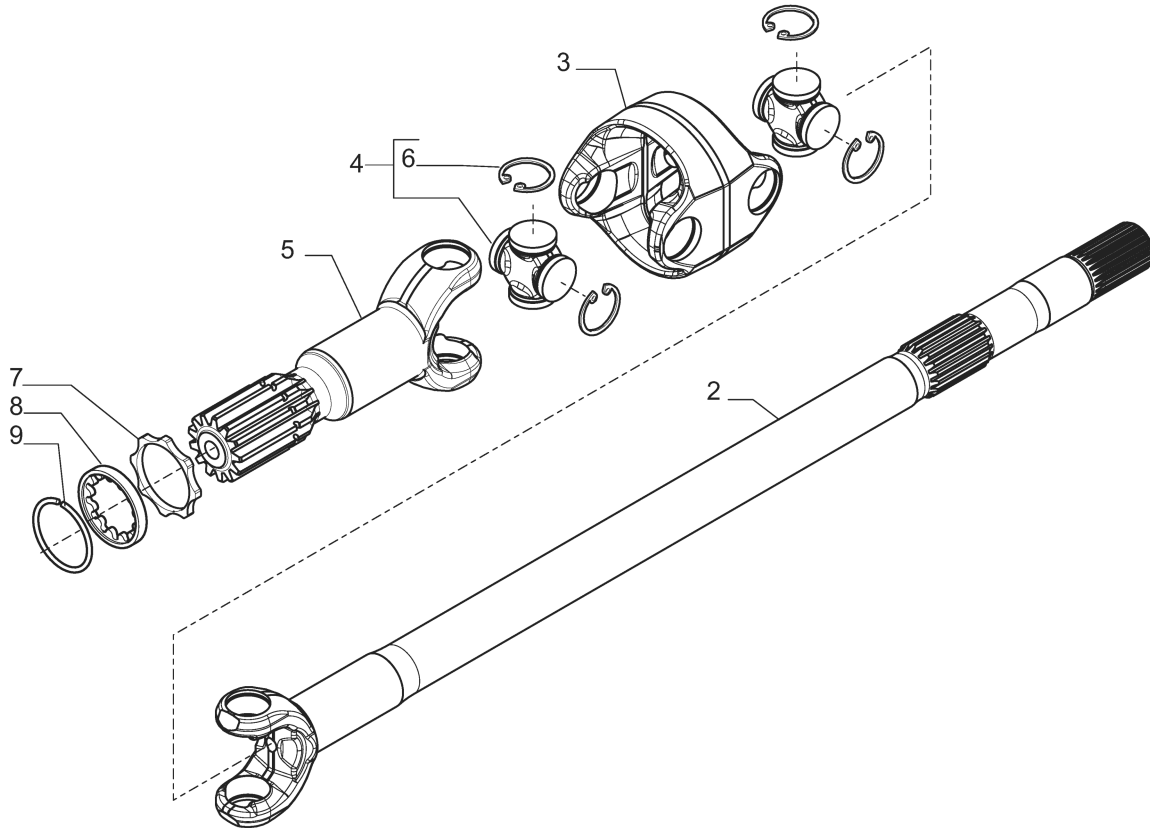

Item	Part Number	Qty.	Description
1	A-ES12-131810	2	SHAFT KIT (INCLUDES ITEMS 2-6)
2	A-ES12-046267	2	FORK (DIFFERENTIAL SIDE)
3	A-ES12-046196	2	CENTRAL BODY
4	A-ES12-046252	4	SPIDER
5	A-ES12-046191	2	FORK (WHEEL SIDE)
6	A-ES12-040822	16	SNAP RING
7	A-ES12-132165	2	WASHER
8	A-ES12-140024	2	WASHER
9	A-ES12-024800	2	SNAP RING

Brakes - Front and Rear Axle

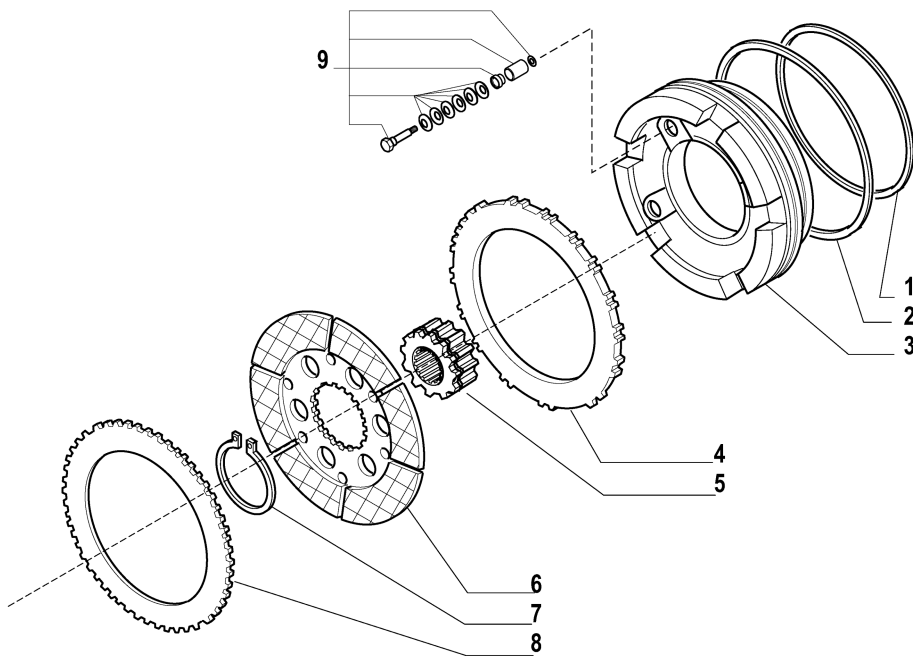

Item	Part Number	Qty.	Description
1	A-ES12-141939	2	O-RING
2	A-ES12-141937	2	O-RING
3	A-ES12-143289	2	BRAKE PISTON
4	A-ES12-136644	2	DRIVE PLATE
5	A-ES12-136648	2	SLEEVE
6	A-ES12-136112	2	BRAKE DISC
7	A-ES12-024819	2	SNAP RING D75
8	A-ES12-136155	2	DRIVE PLATE
9	A-ES12-066573	2	SELF-ADJUST KIT

Wheel Hub - Front and Rear Axle

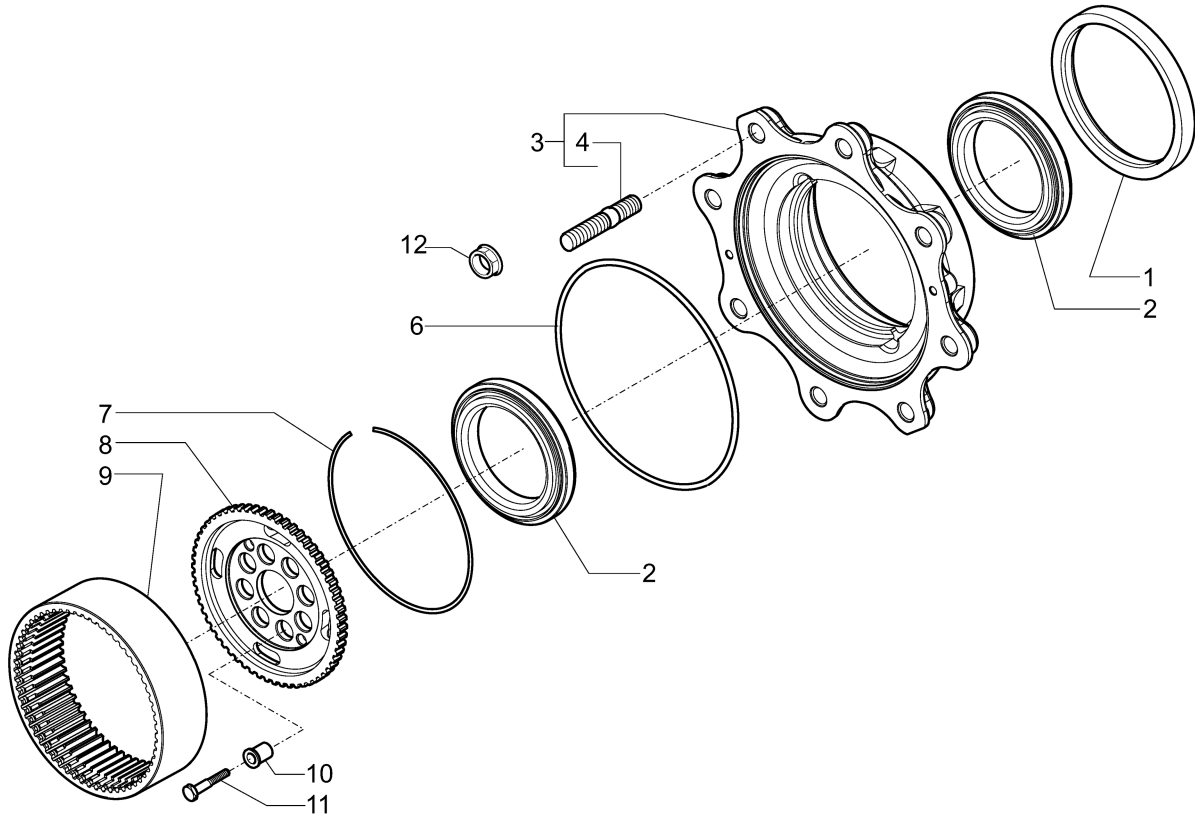

Item	Part Number	Qty.	Description
1	A-ES12-047702	2	SEAL RING
2	A-ES12-045180	4	BEARING
3	A-ES12-066993	2	WHEEL HUB KIT (INCLUDES ITEM 4)
4	A-ES12-130679	16	STUD
6	A-ES12-028668	2	O-RING
7	A-ES12-125344	2	CIRCLIP
8	A-ES12-134298	2	WHEEL CARRIER
9	A-ES12-125452	2	CROWN GEAR Z=60
10	A-ES12-141196	12	CENTERING BUSHING
11	A-ES12-140259	12	BOLT M12X45 (SELF LOCKING)
12	A-ES12-121746	16	WHEEL NUT M18X1.5

Final Reduction - Front and Rear Axle

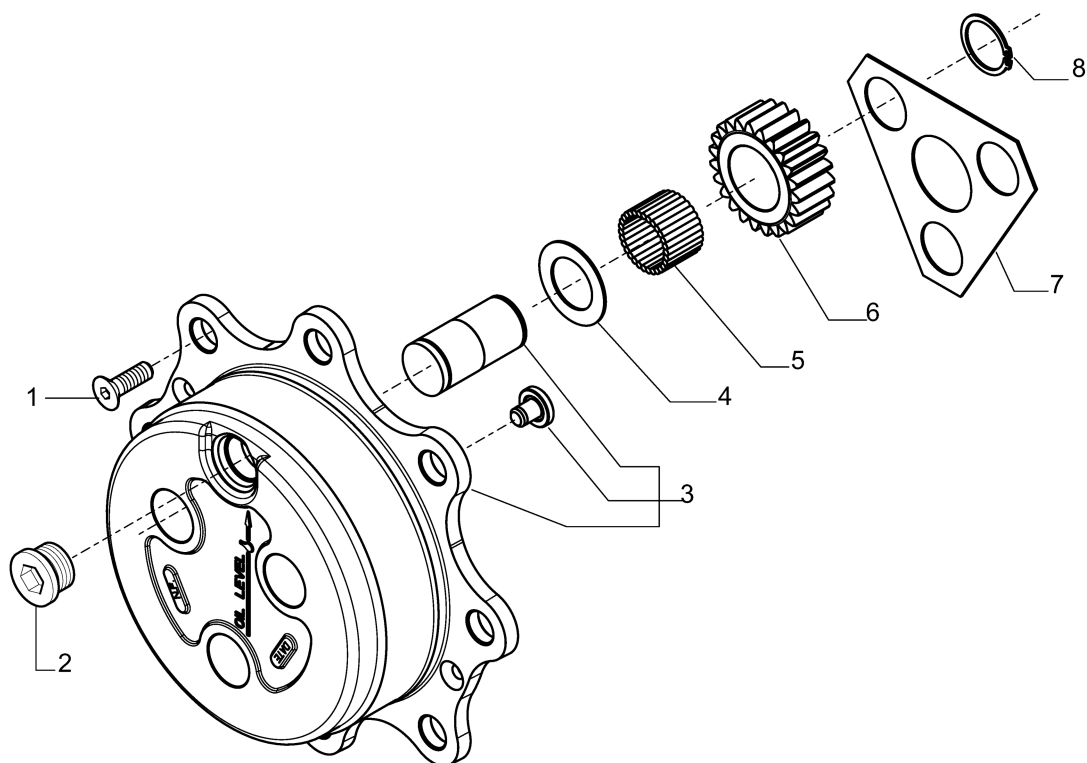

Item	Part Number	Qty.	Description
1	A-ES12-020490	4	BOLT M8X20
2	A-ES12-125280	2	PLUG M30X2
3	A-ES12-065587	2	PLANETARY CARRIER KIT
4	A-ES12-115634	6	THRUST WASHER
5	A-ES12-028299	18	BEARING NEEDLES (BY 10)
6	A-ES12-125455	6	GEAR Z=23
7	A-ES12-123318	2	THRUST WASHER
8	A-ES12-024789	6	SNAP RING D34

Revision Log

Rev	Date	Description	Appr.
A	26-Feb-2014	Original release for production	PRB
B	21-Oct-2015	Corrected wheel nut part number and removed washer from wheel hub assembly.	DCM
C	6-Jun-2016	Changed eXL16 model name to eTT16.	TFP

Table of Contents

Appendix D - Transfer Case	
Description	Page
Transfer Case Service Procedure	D-2
Parts - Transfer Case Housing	D-3
Parts - Gears and Shafts	D-4
Parts - Rear Support	D-5
Revision Log	D-6

Transfer Case Service Procedure

Tractors Under Warranty

For servicing of transfer cases installed in tractors under warranty, please contact Eagle Tugs at 800.671.0431. Eagle Tugs will work with Carraro to determine the best servicing procedure.

Tractors Out of Warranty

If your tractor is no longer under warranty coverage, Eagle Tugs highly recommends working with your local Carraro certified service provider. Carraro has a large worldwide network of dealers and service providers. A local servicer can be found at <http://www.carry4you.it>.

Parts Sales

Eagle has provided in this manual a list of the most common transfer case components that may need replacement. Contact Eagle Tugs Parts Sales at parts@eagletugs.com or 800.671.0431 to order any of these parts or any additional unlisted parts.

Service Work

It is highly recommended that all transfer case service be performed only by a Carraro certified service provider. Proper servicing and parts replacement requires special tools and procedures. Failure to follow proper service procedures can cause damage to the transfer case and void the warranty.

Parts - Transfer Case Housing

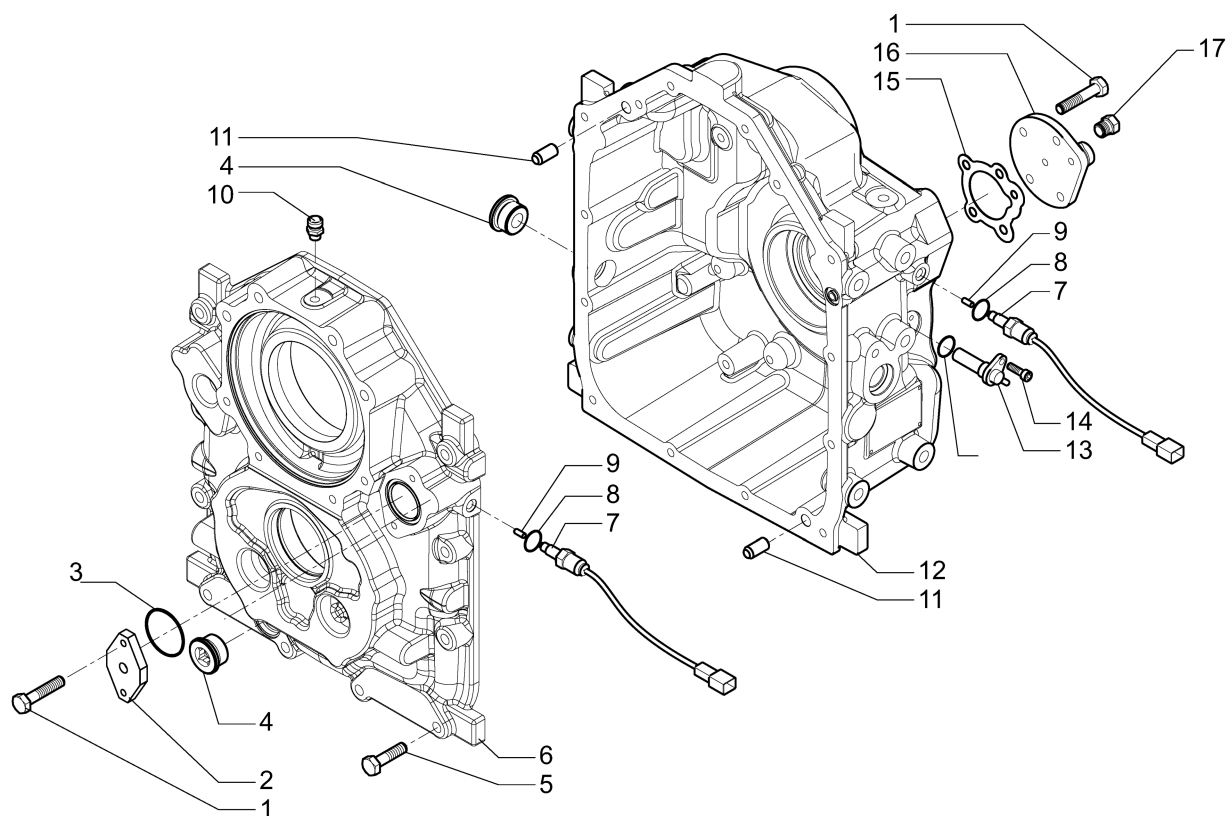

Item	Part Number	Qty.	Description
1	A-ES12-021338	6	BOLT M8X25
2	A-ES12-398329	1	FLANGE
3	A-ES12-028543	1	O-RING
4	A-ES12-125280	2	PLUG
5	A-ES12-020861	10	BOLT M10X50
6	A-ES12-398328	1	FRONT HALF HOUSING
7	A-ES12-146821	2	SWITCH
8	A-ES12-028230	2	O-RING
9	A-ES12-643646	2	PIN
10	A-ES12-137474	1	BREATHER
11	A-ES12-121710	2	PIN D12X25
12	A-ES12-398327	1	REAR HALF HOUSING
13	A-ES12-147514	1	SPEED SENSOR
14	A-ES12-021519	1	BOLT M6X14
15	A-ES12-644316	1	GASKET
16	A-ES12-368681	1	COVER
17	A-ES12-030720	2	PLUG
18	A-ES12-028531	1	O-RING

Parts - Gears and Shafts

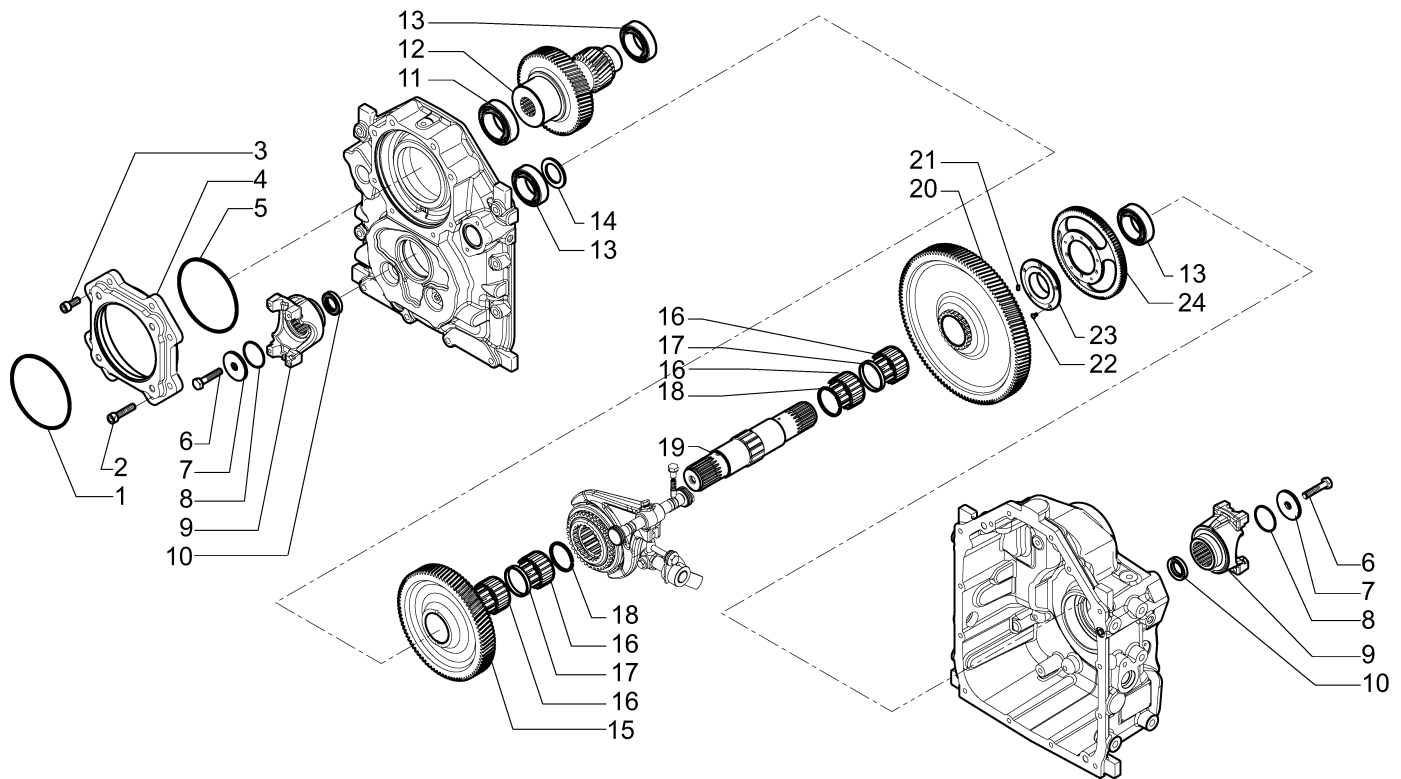

Item	Part Number	Qty.	Description
1	A-ES12-028193	1	O-RING
2	A-ES12-021410	4	BOLT M10X30
3	A-ES12-021430	4	BOLT M10X10
4	A-ES12-127663	1	MOTOR FLANGE
5	A-ES12-028611	1	O-RING
6	A-ES12-021134	2	BOLT M12X25
7	A-ES12-129924	2	WASHER
8	A-ES12-028161	2	O-RING
9	A-ES12-148854	2	FLANGE
10	A-ES12-025485	2	OIL SEAL
11	A-ES12-025744	1	BEARING
12	A-ES12-368529	1	INPUT SHAFT
13	A-ES12-025860	3	BEARING
14	A-ES12-138985	1	THRUST WASHER
15	A-ES12-368530	1	GEAR
16	A-ES12-028015	4	BEARING NEEDLES
17	A-ES12-644324	2	SPACER
18	A-ES12-025520	2	SNAP RING
19	A-ES12-644320	1	OUTPUT SHAFT
20	A-ES12-368531	1	GEAR
21	A-ES12-028372	1	ROLL
22	A-ES12-023779	5	RIVET
23	A-ES12-644323	1	PHONIC WHEEL HUB
24	A-ES12-644322	1	PHONIC WHEEL

Parts - Rear Support

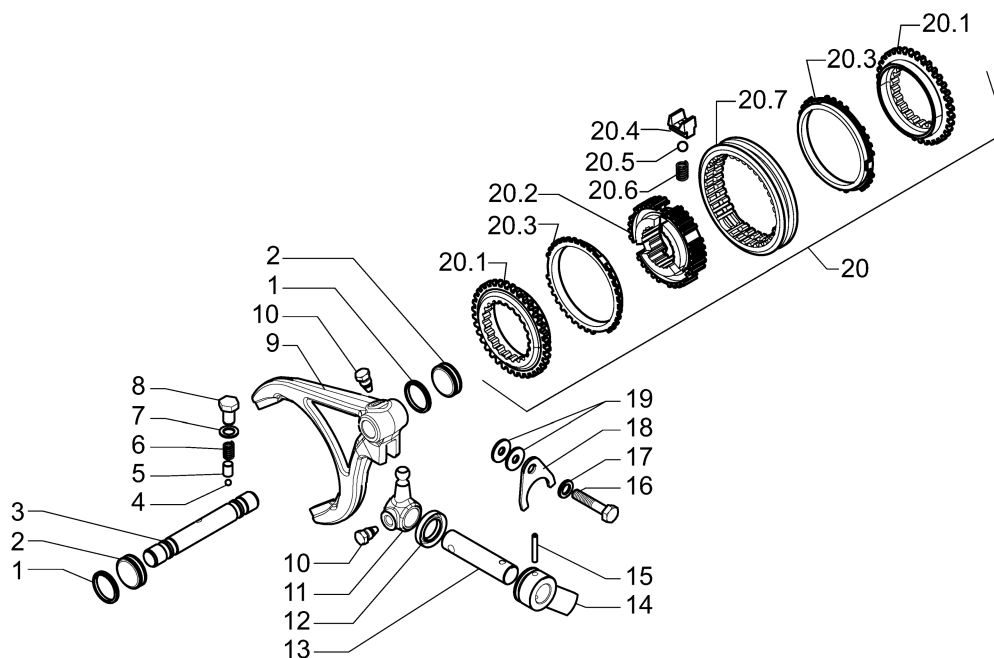

Item	Part Number	Qty.	Description
1	A-ES12-371957	2	OIL SEAL
2	A-ES12-643395	2	PISTON
3	A-ES12-644311	1	PIN
4	A-ES12-028266	1	BALL
5	A-ES12-117124	1	ROLL
6	A-ES12-071352	1	SPRING
7	A-ES12-023288	1	WASHER
8	A-ES12-138003	1	BOLT M12X16
9	A-ES12-644310	1	FORK 1ST-2ND
10	A-ES12-106333	2	BOLT
11	A-ES12-644337	1	LEVER PIN
12	A-ES12-025111	1	OIL SEAL
13	A-ES12-644335	1	PIN
14	A-ES12-127979	1	LEVER
15	A-ES12-024409	1	SPLIT PIN
16	A-ES12-020849	1	BOLT M10X20
17	A-ES12-022859	1	WASHER
18	A-ES12-644336	1	PLATE
19	A-ES12-023071	2	WASHER
20	A-ES12-138548	1	SYNCHRO KIT (INCLUDES 20.1-20.7)
20.1	A-ES12-046329	2	CLUTCH RING
20.2	A-ES12-046328	1	HUB
20.3	A-ES12-046330	2	TAPERED FRICTION RING
20.4	A-ES12-046326	3	PLATE
20.5	A-ES12-046314	3	BALL
20.6	A-ES12-046327	3	SPRING
20.7	A-ES12-046325	1	SLEEVE

Revision Log

Rev	Date	Description	Appr.
A	26-Feb-2014	Original release for production	PRB
B	6-Jun-2016	Changed eXL16 model name to eTT16	TFP