

MALABAR

INTERNATIONAL

AIRCRAFT MAINTENANCE & SUPPORT EQUIPMENT

OWNER'S MANUAL FOR MALABAR MODEL

PF53361-104PWS

2 GALLON FLUID DISPENSER

***READ
AND
SAVE***

**THIS
INSTRUCTION
MANUAL**

- * GENERAL DESCRIPTION
- * OPERATION
- * SERVICE
- * PARTS BREAKDOWN

For Service & Spare
Parts, Please Contact:

Malabar International
220 W. Los Angeles Avenue
Simi Valley, California 93065
Phone: (805) 581-0116
Fax: (805) 584-1624
E-mail: sales@malabar.com
Web site: <http://www.malabar.com>

OVER 65 YEARS OF SERVICE & EXPERIENCE

GENERAL DESCRIPTION, OPERATION, SERVICE AND PARTS BREAKDOWN

MALABAR MODEL PF53361-104PWS 2 GALLON FLUID DISPENSER

CAUTION: AIRCRAFT MANUFACTURER'S SPECIFICATIONS AND INSTRUCTIONS MUST BE FOLLOWED. IN THE EVENT OF CONTRADICTION BETWEEN AIRCRAFT MANUFACTURER'S SPECIFICATIONS AND MALABAR'S, AIRCRAFT MANUFACTURER'S WILL PREVAIL.

SPECIFICATIONS:

Fluid -----	TURBO OIL 2197	
Reservoir capacity -----	2 U.S. gal	7.6 liters
Pump outlet pressure -----	100 psig	689 kPa
Volume per stroke-----	2.5 cubic in	41 cc
Relief valve setting-----	125 ± 10 psig	862 ± 69 kPa
Hose length -----	120 in	3048 mm
Net weight (empty)-----	12 lbs	5.4 kg
Filter rating -----	1 micron nominal	
Fluid tank color-----	yellow	

GENERAL DESCRIPTION:

The Malabar Model PF53361-104PWS is a 2 gallon fluid dispenser used to service various commercial aircraft. The hand pump dispenser consists of a reservoir, pump assembly, relief valve, water stop filter assembly, fluid meter and a fluid delivery hose with a coupling and gravity fill adapter assembly.

PREPARATION FOR USE:

The unit is shipped fully assembled. Fill reservoir at fillport with approved fluid. Operate hand pump assembly a few strokes to bleed all air out of the system. The unit is now ready for use.

OPERATION:

1. Remove dust plug from hose coupling and connect the hose coupling to the aircraft service point or connect coupling to gravity fill adapter assembly.
2. Use full steady pumping strokes when operating pump assembly during replenishing.
3. Disconnect the hose coupling or gravity fill adapter assembly from the aircraft service point, replace the dust plug and store the unit in a dry, dust free location.

ILLUSTRATED PARTS LIST:

Refer to figure 1A & 1B for unit assembly (see sheets 3 & 4), figure 2 for pump assembly (see sheet 5) or figure 3 for filter assembly (see sheet 6).

SERVICING:

1. The frequency of filter change depends on operating conditions. Generally, changes should be made every 3-4 months or sooner if more than normal resistance is felt on the pumping stroke at low pressure. Refer to item 10 in figure 3 (see sheet 6) to change element. Proper element must be installed, otherwise unit will not pump fluid.
2. NOTE: The relief valve should not be removed. The relief valve is set to by-pass oil back to the reservoir at 125 ± 10 PSIG.

REPAIR AND REPLACEMENT:

No definite time schedule can be established for the overhaul of the pump assembly for the replacement of the various moving parts. The number of times the pump assembly is operated materially affect the life of the working parts. The moving piston seal (item 6) and rod seal (item 11) are normally the first to wear (see sheet 5). This is usually indicated by leakage of fluid past the piston or rod. It is advisable to change piston seal (item 6), rod seal (item 11) and gasket (item 16) immediately if leakage is discovered. A repair parts kit (P/N PF2-60PK) is available and recommended to keep on hand at your facility. Refer to sheet 7 for the complete list of parts contained in the repair parts kit.

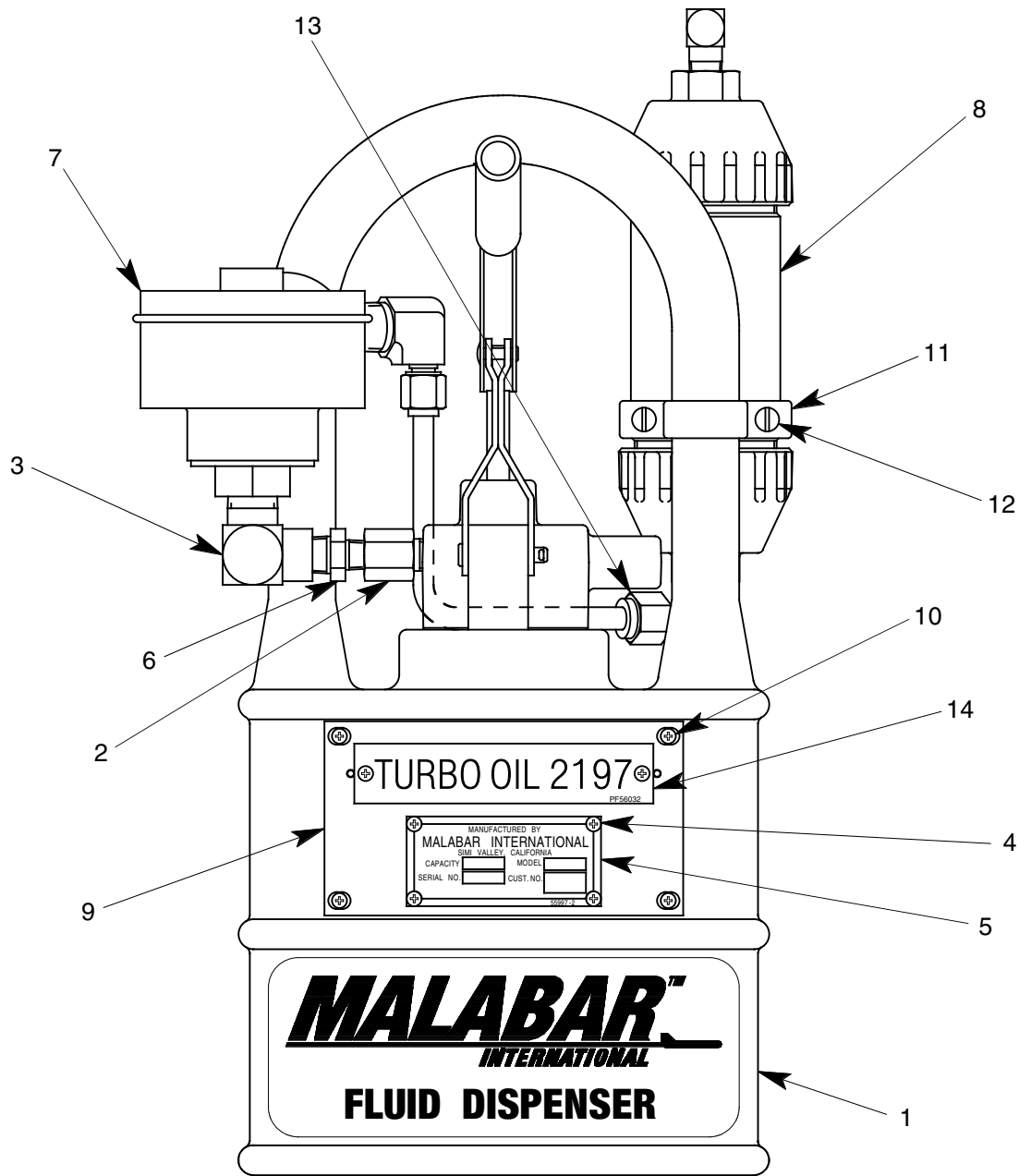
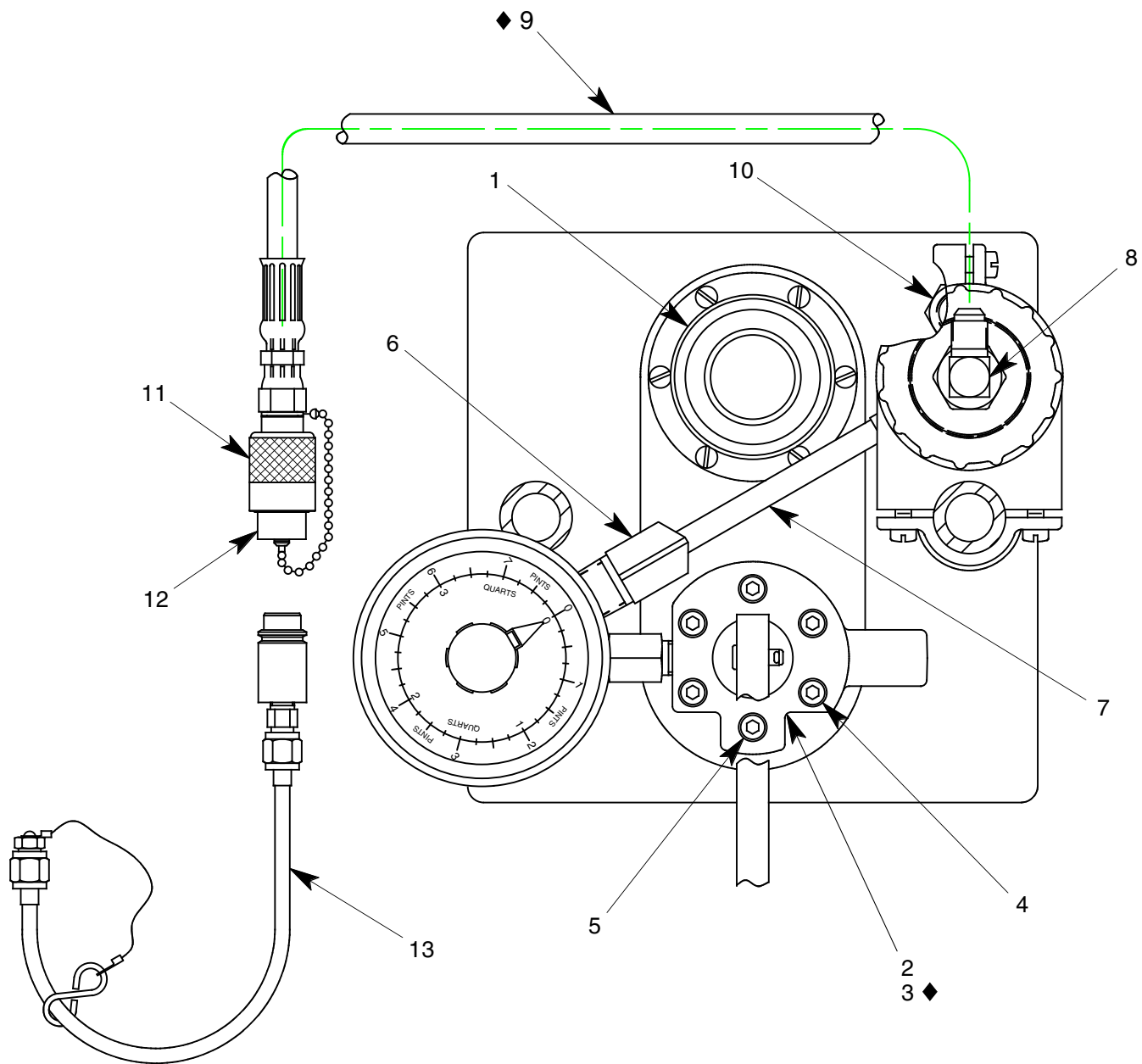

FIGURE 1A

PF53361-104PWS UNIT ASSEMBLY

NO.	QTY	PART NO.	PART NAME	NO.	QTY	PART NO.	PART NAME
1	1	PF55838-7	FLUID TANK	8	1	PF55873	FILTER ASSEMBLY
2	1	714-017	BUSHING, 1/4 NPT	9	1	PF55859	PLACARD PLATE
3	1	712-032	ELBOW, 1/2 NPT x 3/8 NPT	10	4	344-011	FHMS, 6-32 x 7/16 LG
4	6	397-010	SELF TAPPING SCREW, 6-32	11	1	PF55871-1	YOKE CLAMP
5	1	55997-2	NAMEPLATE	12	3	342-010	SCREW, FIL HD, 1/4-20 x 1" LG
6	1	711-018	REDUCER, 3/8 NPT x 1/4 NPT	13	1	722-014	ELBOW, 3/8 TUBE x 1/4 NPT
7	1	486-024	FLUID METER	14	1	PF56032	PLACARD, TURBO OIL 2197



◆ PART OF REPAIR PARTS KIT

FIGURE 1B

PF53361-104PWS UNIT ASSEMBLY

NO.	QTY	PART NO.	PART NAME	NO.	QTY	PART NO.	PART NAME
1	1	PF55447	FILLPORT ASSEMBLY	8	1	722-005	ELBOW, 3/8 37° x 1/4 NPT
2	1	PF55845-1	PUMP ASSEMBLY	9	1	PF55456	HOSE ASSEMBLY
3	1	PF55672	GASKET	10	1	717-007	PLUG, 3/8 NPT
4	5	323-038	SHCS, 1/4-28 x 1 3/4 LG	11	1	736-013	COUPLING
5	1	323-063	SHCS, 1/4-28 x 1" LG	12	1	PF55987	DUST PLUG & CHAIN
6	1	722-015	ELBOW, 3/8 TUBE x 1/2 NPT	13	1	PF55759	GRAVITY FILL ADAPTER
7	AR	732-010	TUBING, 3/8 OD x .065 WALL				

◆ PART OF REPAIR PARTS KIT

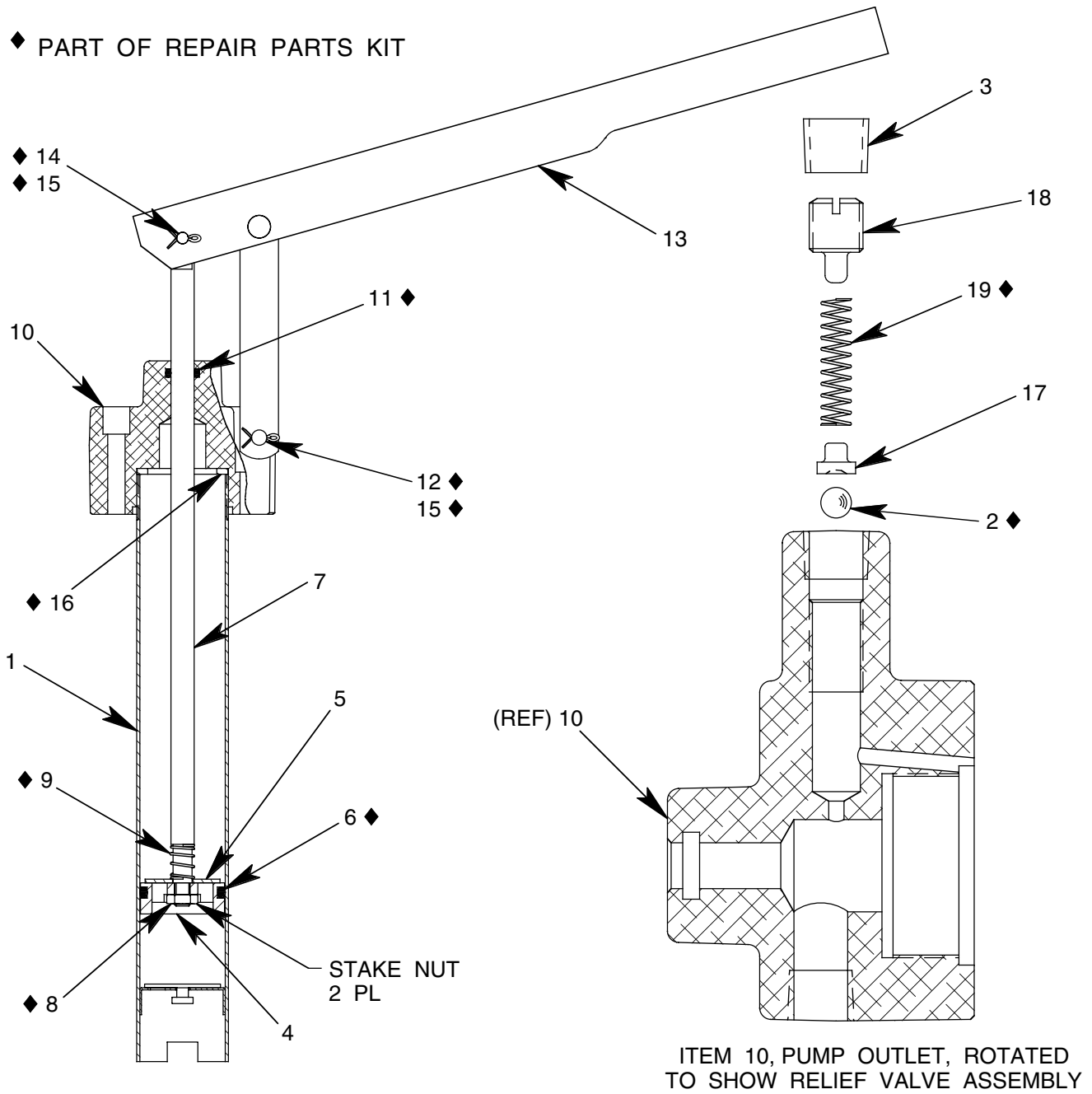
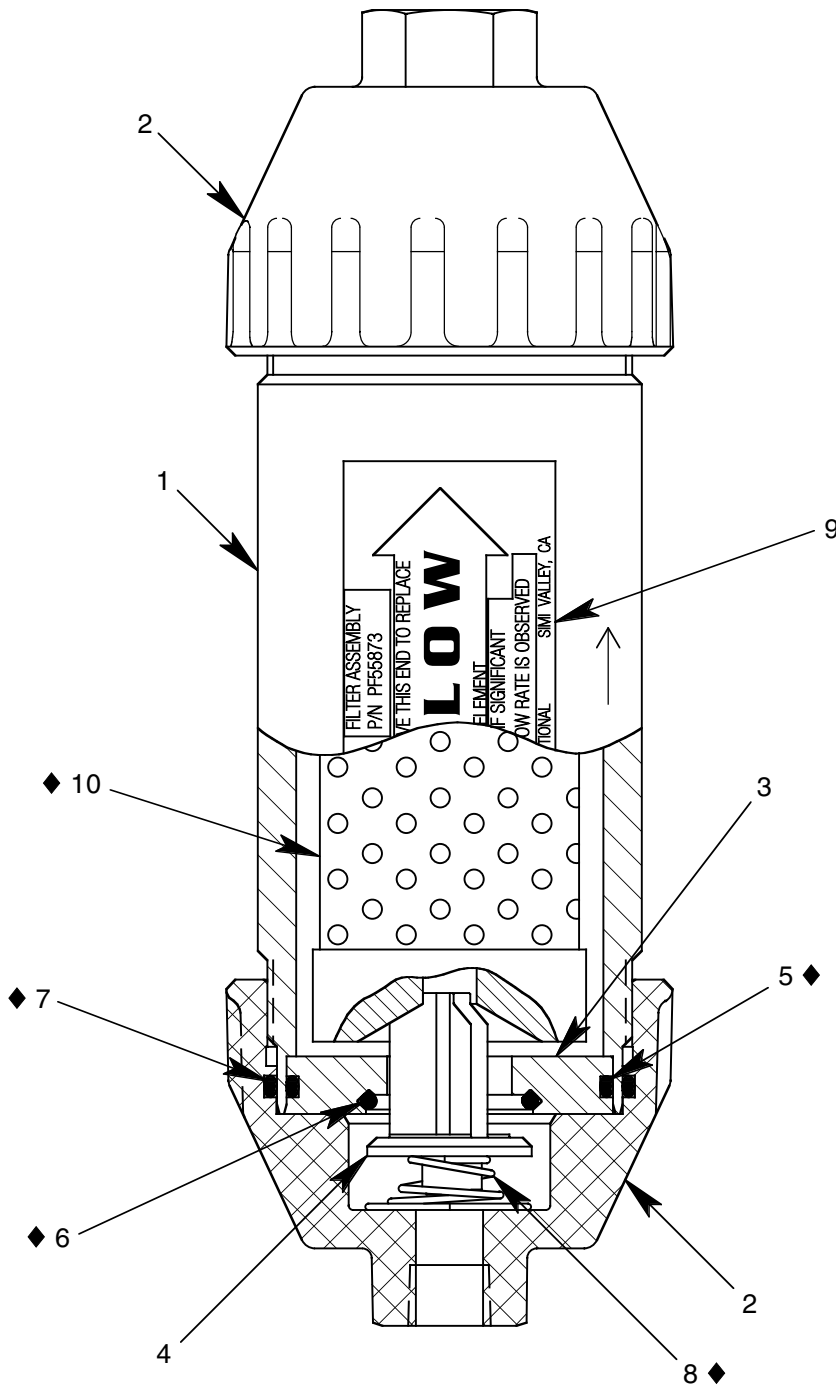

FIGURE 2

PF55845-1 PUMP ASSEMBLY

NO.	QTY	PART NO.	PART NAME	NO.	QTY	PART NO.	PART NAME
1	1	PF53376	TUBE ASSEMBLY	11	1	55925-110	O-RING
2	1	412-004	STEEL BALL, 1/4 DIA	12	1	373-006	FH PIN, 1/4 DIA x 1 9/32 LG
3	1	717-006	PLUG, 1/4 NPT	13	1	494-017	HANDLE ASSEMBLY
4	1	PF53379	PISTON	14	1	AN393-17	FH PIN, 3/16 DIA x 17/32 LG
5	1	PF53380	PISTON CHECK DISC	15	2	372-011	COTTER PIN, 1/16 x 1/2 LG
6	1	55925-216	O-RING	16	1	PF54063	GASKET
7	1	PF53378	PUMP PISTON ROD	17	1	55153	SPRING GUIDE
8	1	352-011	HEX JAM NUT, 1/4-28	18	1	55148	SET SCREW
9	1	PF53406	SPRING	19	1	495-038	SPRING
10	1	PF55820-1	PUMP OUTLET				



◆ PART OF REPAIR PARTS KIT

FIGURE 3

PF55873 FILTER ASSEMBLY

NO.	QTY	PART NO.	PART NAME	NO.	QTY	PART NO.	PART NAME
1	1	PF55849	FILTER HOUSING	6	1	55925-120	O-RING
2	2	PF55852	FILTER HOUSING END CAP	7	2	55925-140	O-RING
3	1	PF55853	RETAINER DISC	8	1	495-039	SPRING
4	1	PF55850	RETAINER VALVE	9	1	PF55872	DECAL, FLOW
5	1	55925-135	O-RING	10	1	481-068	FILTER ELEMENT

PF2-60PK REPAIR PARTS KIT

QTY	PART NO.	PART NAME
1	PF55456	HOSE ASSEMBLY
1	55925-216	O-RING
1	55925-110	O-RING
1	PF53406	SPRING
1	373-006	FLAT HEAD PIN, 1/4 DIA x 1 9/32 LG
2	372-011	COTTER PIN, 1/16 x 1/2 LG
1	AN393-17	FLAT HEAD PIN, 3/16 DIA x 17/32 LG
1	PF54063	GASKET
1	495-038	SPRING
1	412-004	STEEL BALL, 1/4 DIA
1	55925-135	O-RING
1	55925-120	O-RING
2	55925-140	O-RING
1	495-039	SPRING
1	481-068	FILTER ELEMENT
1	352-011	HEX JAM NUT, 1/4-28
1	PF55672	GASKET
1	PF2-60PKDOC	REPAIR PARTS KIT LIST