

MALABAR

INTERNATIONAL

AIRCRAFT MAINTENANCE & SUPPORT EQUIPMENT

OWNER'S MANUAL FOR MALABAR MODEL

PF54115-64P

2 GALLON FLUID DISPENSER

***READ
AND
SAVE***

**THIS
INSTRUCTION
MANUAL**

- * GENERAL DESCRIPTION
- * OPERATION
- * SERVICE
- * PARTS BREAKDOWN

For Service & Spare
Parts, Please Contact:

Malabar International
220 W. Los Angeles Avenue
Simi Valley, California 93065
Phone: (805) 581-0116
Fax: (805) 584-1624
E-mail: sales@malabar.com
Web site: <http://www.malabar.com>

OVER 65 YEARS OF SERVICE & EXPERIENCE

GENERAL DESCRIPTION, OPERATION, SERVICE AND PARTS BREAKDOWN

***MALABAR MODEL PF54115-64P
2 GALLON FLUID DISPENSER***

CAUTION: AIRCRAFT MANUFACTURER'S SPECIFICATIONS AND INSTRUCTIONS MUST BE FOLLOWED. IN THE EVENT OF CONTRADICTION BETWEEN AIRCRAFT MANUFACTURER'S SPECIFICATIONS AND MALABAR'S, AIRCRAFT MANUFACTURER'S WILL PREVAIL.

SPECIFICATIONS:

Fluid -----	SKYDROL/HYJET IV FLUID	
Reservoir capacity -----	2 U.S. gal	7.6 liters
Pump outlet pressure -----	100 psig	689 kPa
Volume per stroke-----	2.5 cubic in	41 cc
Hose length-----	120 in	3048 mm
Net weight (empty)-----	12 lbs	5.4 kg
Filter rating-----	3 micron absolute	
Fluid tank color-----	purple	

GENERAL DESCRIPTION:

The Malabar Model PF54115-64P is a 2 gallon fluid dispenser used to service various commercial aircraft. The hand pump dispenser consists of a reservoir, pump assembly, filter assembly, and a fluid delivery hose with a coupling.

PREPARATION FOR USE:

The unit is shipped fully assembled. Fill reservoir at fillport with approved fluid. Operate hand pump assembly a few strokes to bleed all air out of the system. The unit is now ready for use.

OPERATION:

1. Remove dust plug from hose coupling and connect the hose coupling to the aircraft service point.
2. Use full steady pumping strokes when operating pump assembly during replenishing.
3. Disconnect the hose coupling from the aircraft service point, replace the dust plug and store the unit in a dry, dust free location.

ILLUSTRATED PARTS LIST:

Refer to figure 1A & 1B for unit assembly (see sheets 3 & 4) or figure 2 for pump assembly (see sheet 5).

SERVICING:

1. The frequency of filter change depends on operating conditions. Generally, changes should be made every 3-4 months or sooner if more than normal resistance is felt on the pumping stroke at low pressure. Refer to item 8 in figure 1A (see sheet 3) to change element.

REPAIR AND REPLACEMENT:

No definite time schedule can be established for the overhaul of the pump assembly for the replacement of the various moving parts. The number of times the pump assembly is operated materially affect the life of the working parts. The moving piston seal (item 4) and rod seal (item 14) are normally the first to wear (see sheet 5). This is usually indicated by leakage of fluid past the piston or rod. It is advisable to change piston seal (item 4), rod seal (item 14) and gasket (item 13) immediately if leakage is discovered. A repair parts kit (P/N PF2-81PK) is available and recommended to keep on hand at your facility. Refer to sheet 6 for the complete list of parts contained in the repair parts kit.

◆ PART OF REPAIR PARTS KIT

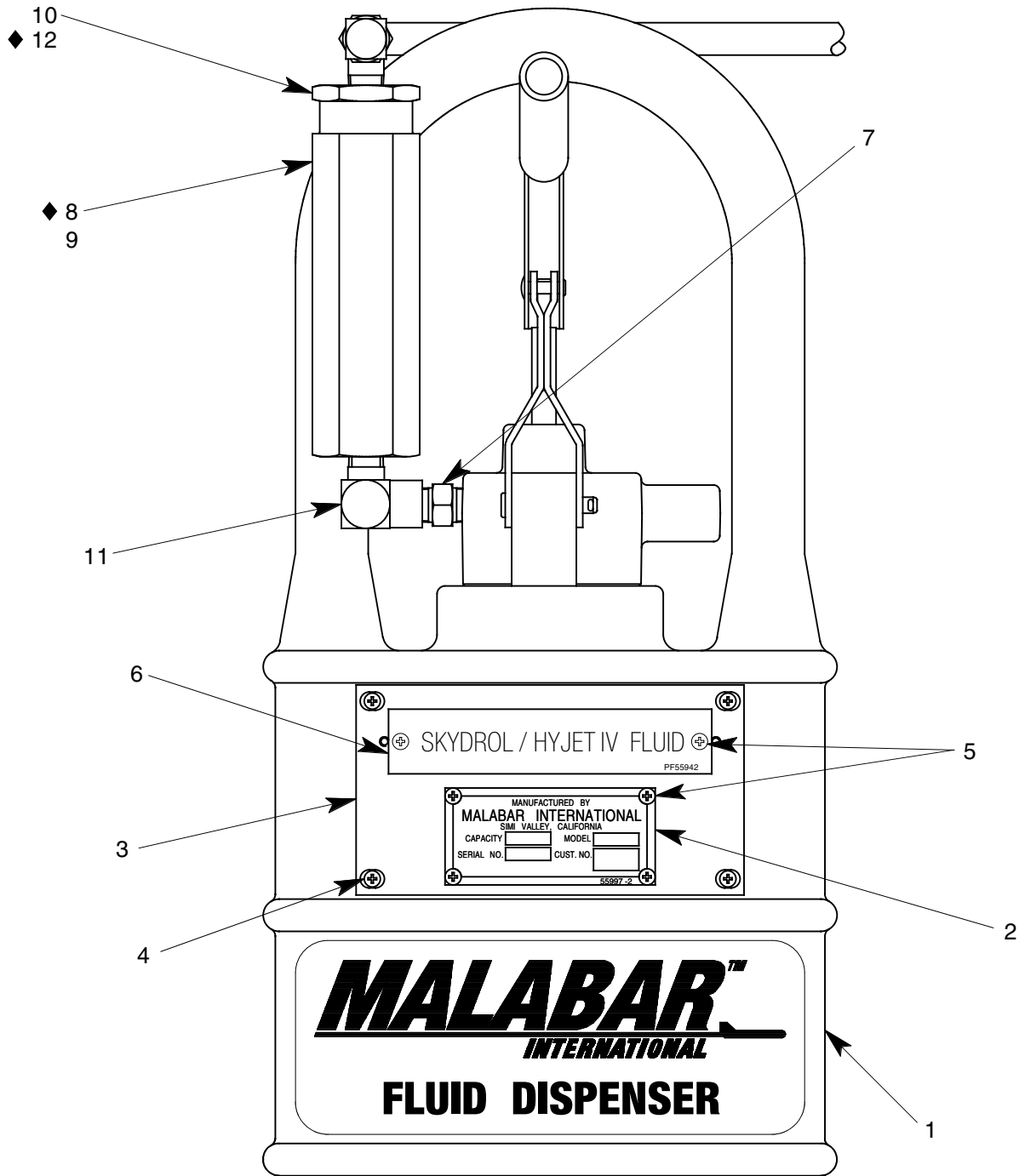
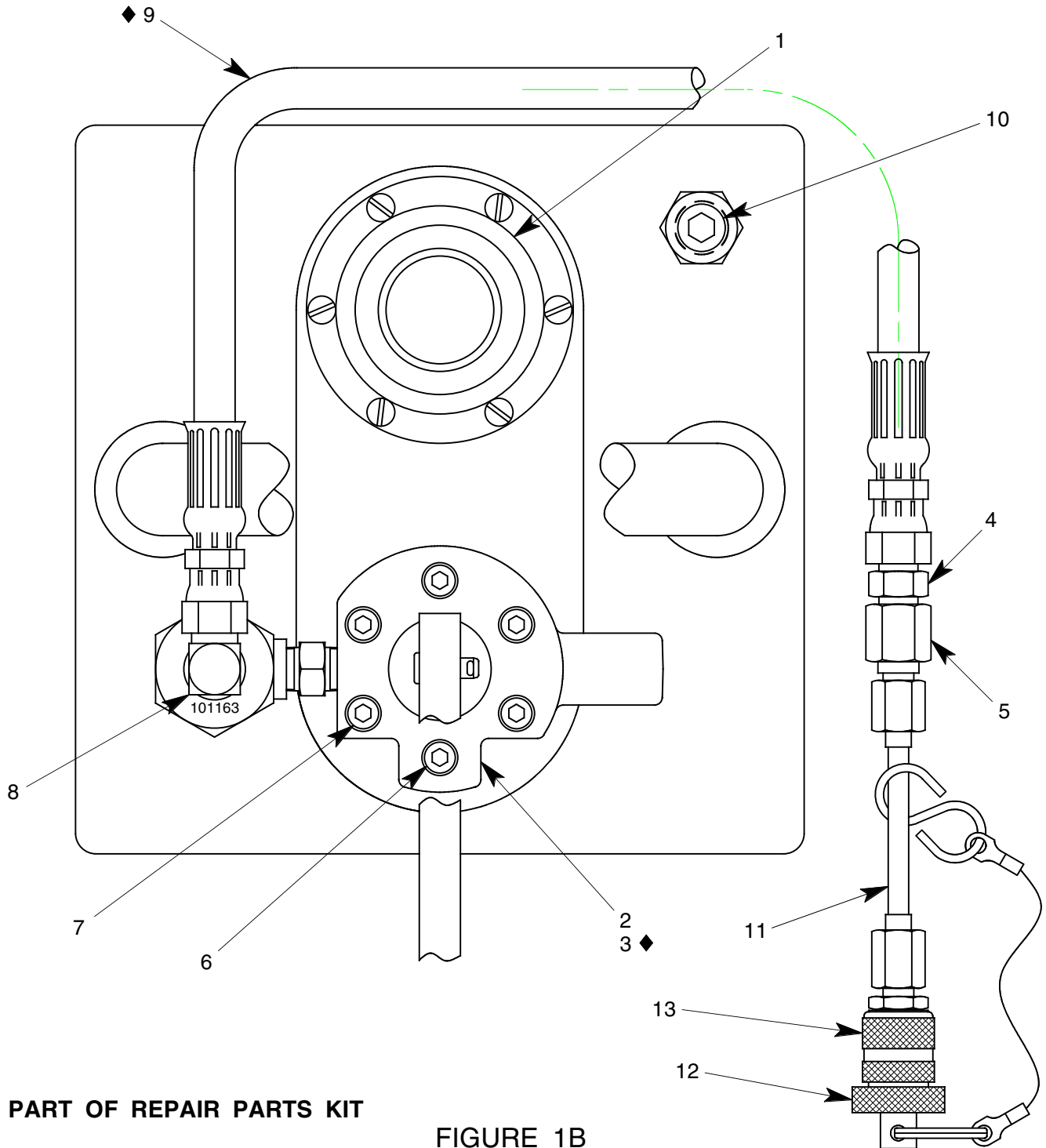

FIGURE 1A

PF54115-64P UNIT ASSEMBLY

NO.	QTY	PART NO.	PART NAME	NO.	QTY	PART NO.	PART NAME
1	1	PF55838-2	FLUID TANK	7	1	711-003	NIPPLE, 1/4 NPT
2	1	55997-2	NAMEPLATE	8	1	481-039	FILTER ELEMENT
3	1	PF55859	PLACARD PLATE	9	1	PF101161	FILTER HOUSING
4	4	344-011	FHCS, 6-32 x 7/16 LG	10	1	PF101163	END CAP, FILTER HOUSING
5	6	397-010	SELF TAPPING SCREW, 6-32	11	1	712-008	ELBOW, STREET, 1/4 NPT
6	1	PF55942	PLACARD, SKYDROL/HYJET IV	12	1	55930-025	O-RING



◆ PART OF REPAIR PARTS KIT

FIGURE 1B

PF54115-64P UNIT ASSEMBLY

NO.	QTY	PART NO.	PART NAME	NO.	QTY	PART NO.	PART NAME
1	1	PF55447	FILLPORT ASSEMBLY	8	1	722-005	ELBOW
2	1	PF53415A-2	PUMP ASSEMBLY	9	1	PF55470	HOSE ASSEMBLY
3	1	PF55672	GASKET	10	1	717-007	PLUG, 3/8 NPT
4	1	721-006	CONNECTOR, 3/8 37° FLARE	11	1	PF55668	COUPLING ASSEMBLY
5	1	714-019	REDUCER, 3/8 x 1/4 37°	12	1	PF55680	DUST PLUG & CABLE ASSY
6	1	323-063	SHCS, 1/4-28 x 1" LG	13	1	736-030	COUPLING
7	5	323-038	SHCS, 1/4-28 x 1 3/4 LG				

◆ PART OF REPAIR PARTS KIT

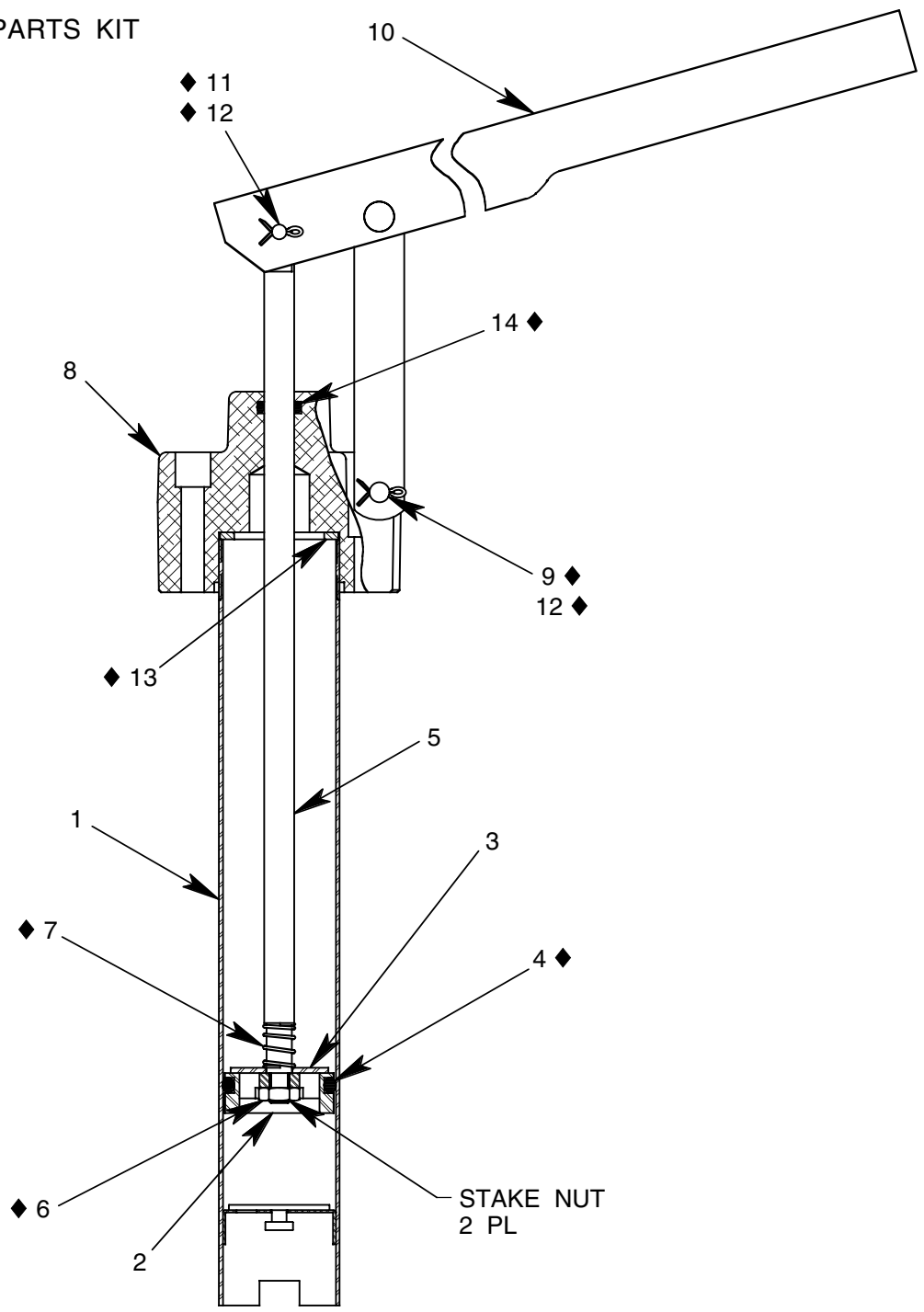

FIGURE 2

PF53415A-2 PUMP ASSEMBLY

NO.	QTY	PART NO.	PART NAME	NO.	QTY	PART NO.	PART NAME
1	1	PF53376	TUBE ASSEMBLY	8	1	PF55685	PUMP OUTLET
2	1	PF53379	PISTON	9	1	373-006	FH PIN, 1/4 DIA x 1 9/32 LG
3	1	PF53380	PISTON CHECK DISC	10	1	494-017	HANDLE ASSEMBLY
4	1	55930-216	O-RING	11	1	AN393-17	FH PIN, 3/16 DIA x 17/32 LG
5	1	PF53378	PUMP PISTON ROD	12	2	372-011	COTTER PIN, 1/16 x 1/2 LG
6	1	352-011	HEX JAM NUT, 1/4-28	13	1	PF54063	GASKET
7	1	PF53406	SPRING	14	1	55930-110	O-RING

PF2-81PK REPAIR PARTS KIT

QTY	PART NO.	PART NAME
1	PF55470	HOSE ASSEMBLY
1	481-039	FILTER ELEMENT
1	55930-025	O-RING
1	PF55672	GASKET
1	PF53406	SPRING
1	AN393-17	FLAT HEAD PIN, 3/16 DIA x 17/32 LG
1	352-011	HEX JAM NUT, 1/4-28
2	372-011	COTTER PIN, 1/16 DIA x 1/2 LG
1	373-006	FLAT HEAD PIN, 1/4 DIA x 1 9/32 LG
1	55930-216	O-RING
1	55930-110	O-RING
1	PF54063	GASKET
1	PF2-81PKDOC	REPAIR PARTS KIT LIST