

# **MALABAR**

**INTERNATIONAL**

***AIRCRAFT MAINTENANCE & SUPPORT EQUIPMENT***

***OWNER'S MANUAL FOR MALABAR MODEL***

## **PF55518-2**

***2 GALLON FLUID DISPENSER***

***READ  
AND  
SAVE***

**THIS  
INSTRUCTION  
MANUAL**

- \* GENERAL DESCRIPTION
- \* OPERATION
- \* SERVICE
- \* PARTS BREAKDOWN

For Service & Spare  
Parts, Please Contact:

Malabar International  
220 W. Los Angeles Avenue  
Simi Valley, California 93065  
Phone: (805) 581-0116  
Fax: (805) 584-1624  
E-mail: [sales@malabar.com](mailto:sales@malabar.com)  
Web site: <http://www.malabar.com>

***OVER 65 YEARS OF SERVICE & EXPERIENCE***

## GENERAL DESCRIPTION, OPERATION, SERVICE AND PARTS BREAKDOWN

### ***MALABAR MODEL PF55518-2 2 GALLON FLUID DISPENSER***

**CAUTION:** AIRCRAFT MANUFACTURER'S SPECIFICATIONS AND INSTRUCTIONS MUST BE FOLLOWED. IN THE EVENT OF CONTRADICTION BETWEEN AIRCRAFT MANUFACTURER'S SPECIFICATIONS AND MALABAR'S, AIRCRAFT MANUFACTURER'S WILL PREVAIL.

#### **SPECIFICATIONS:**

Fluid -----	MIL-PRF-5606	
Reservoir capacity -----	2 U.S. gal	7.6 liters
Pump outlet pressure -----	500 psig	3447 kPa
Volume per stroke-----	1.4 cubic in	23 cc
Relief valve setting-----	500 ± 10 psig	3447 ± 69 kPa
Hose length -----	84 in	2134 mm
Net weight (empty)-----	15 lbs	6.8 kg
Filter rating -----	3 micron nominal	
Fluid tank -----	stainless steel	

#### **GENERAL DESCRIPTION:**

The Malabar Model PF55518-2 is a 2 gallon fluid dispenser used to service various commercial aircraft. The hand pump dispenser consists of a reservoir, pump assembly, filter assembly, check valve, relief valve, by-pass valve, pressure gauge and a fluid delivery hose.

#### **PREPARATION FOR USE:**

The unit is shipped fully assembled. Fill reservoir at fillport with approved fluid. Operate hand pump assembly a few strokes to bleed all air out of the system. The unit is now ready for use.

## **OPERATION:**

1. Close by-pass valve.
2. Connect the hose to the aircraft service point.
3. Use full steady pumping strokes when operating pump assembly.
4. Open by-pass valve to allow fluid to drain to reservoir.
5. Disconnect the hose from the aircraft service point and store the unit in a dry, dust free location.

## **ILLUSTRATED PARTS LIST:**

Refer to figures 1A & 1B for unit assembly (see sheets 3 & 4) or figure 2 for pump assembly (see sheet 5).

## **HYDRAULIC DIAGRAM:**

Refer to figure 3 for hydraulic diagram (see sheet 6).

## **SERVICING:**

1. The frequency of filter change depends on operating conditions. Generally, changes should be made every 3-4 months or sooner if more than normal resistance is felt on the pumping stroke at low pressure. Refer to item 13 in figure 1A (see sheet 3) to change element.
2. NOTE: The relief valve should not be removed. The relief valve is set to by-pass oil back to the reservoir at  $500 \pm 10$  PSIG.

## **REPAIR AND REPLACEMENT:**

No definite time schedule can be established for the overhaul of the pump assembly for the replacement of the various moving parts. The number of times the pump assembly is operated materially affect the life of the working parts. The moving piston seal (item 4) and rod seal (item 14) are normally the first to wear (see sheet 5). This is usually indicated by leakage of fluid past the piston or rod. It is advisable to change piston seal (item 4), rod seal (item 14) and static seal (item 13) immediately if leakage is discovered. A repair parts kit (P/N PF2-57PK) is available and recommended to keep on hand at your facility. Refer to sheet 7 for the complete list of parts contained in the repair parts kit.

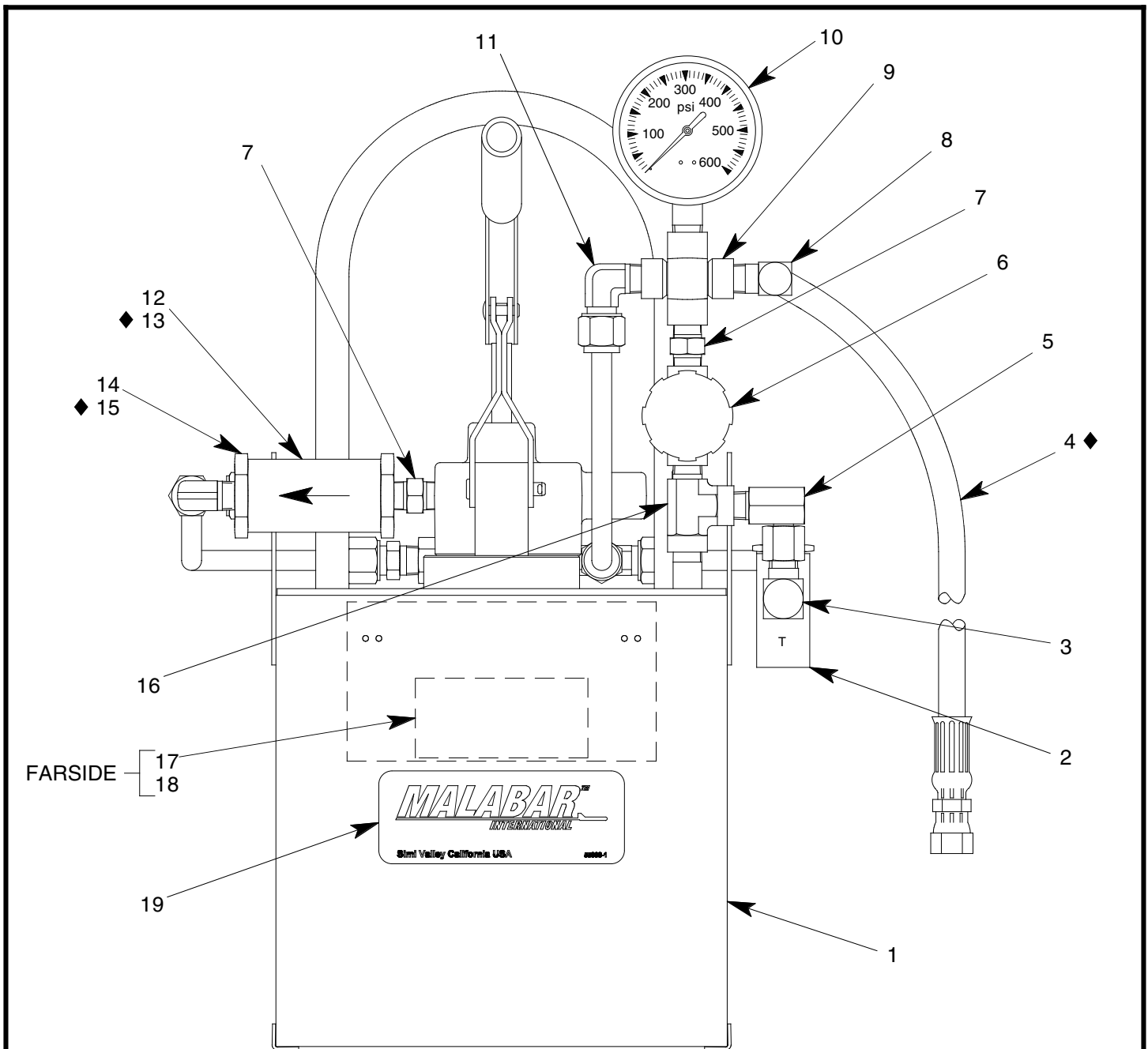

◆ PART OF REPAIR PARTS KIT

FIGURE 1A

**PF55518-2 UNIT ASSEMBLY**

NO.	QTY	PART NO.	PART NAME	NO.	QTY	PART NO.	PART NAME
1	1	PF55428-2	FLUID TANK	11	1	722-014	ELBOW, 3/8 TUBE x 1/4 MPT
2	1	423-002	RELIEF VALVE	12	1	PF712721	FILTER HOUSING
3	1	712-008	ELBOW, STREET, 1/4 NPT	13	1	481-005	FILTER ELEMENT
4	1	PF55566-2	HOSE ASSEMBLY	14	1	PF712722	FILTER RETAINER
5	1	719-013	ELBOW, SWIVEL, 1/4 NPT	15	1	55925-120	O-RING
6	1	424-017	BY-PASS VALVE	16	1	713-012	RUN TEE, 1/4 NPT
7	2	711-003	NIPPLE, 1/4 NPT	17	1	55997-2	NAMEPLATE
8	1	722-005	ELBOW, 3/8 37° x 1/4 MPT	18	4	397-010	SELF TAPPING SCREW, 6-32
9	1	715-002	CROSS, 1/4 NPT	19	1	55998-1	STICKER, MALABAR
10	1	482-014	GAUGE				

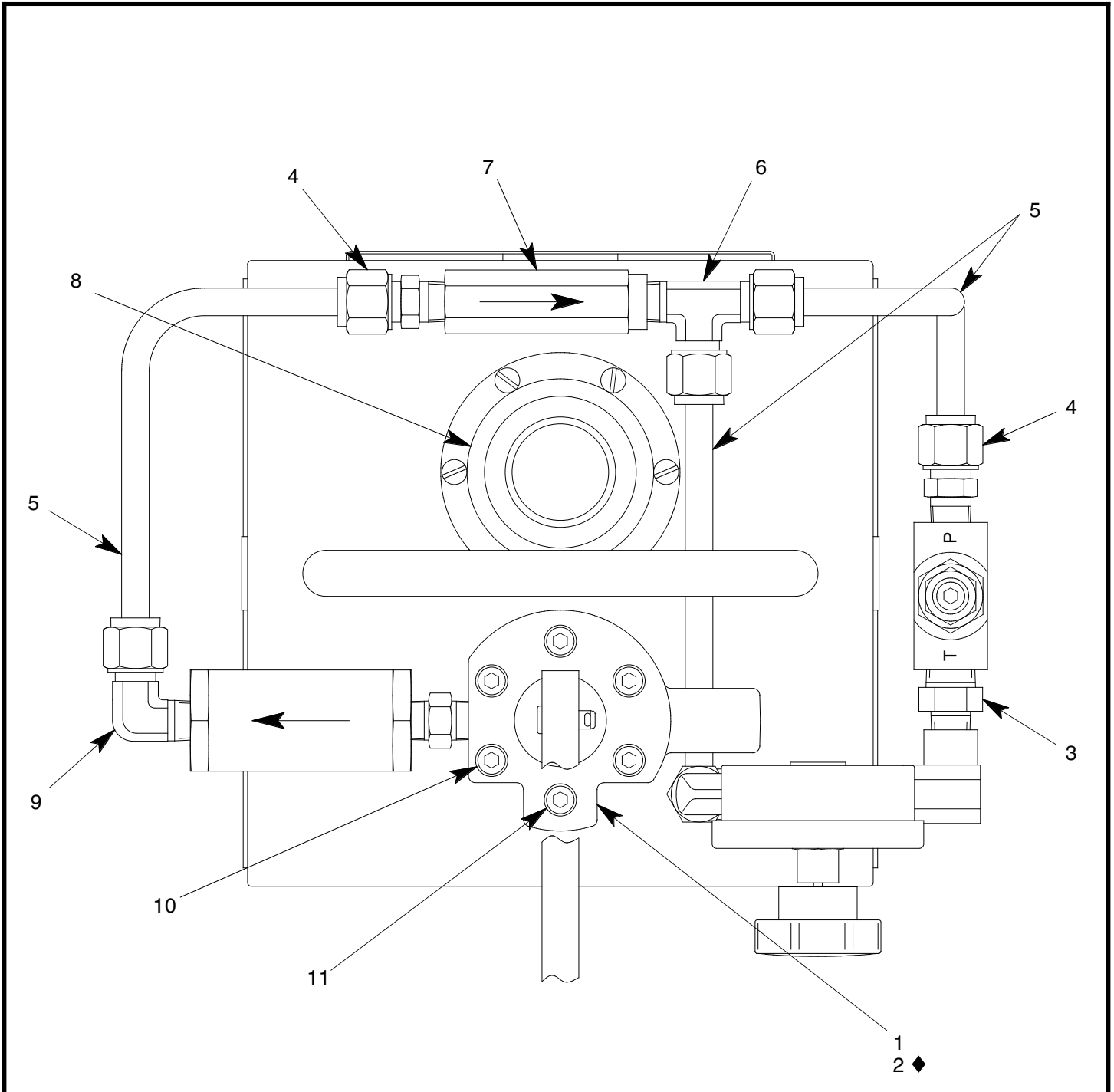

◆ PART OF REPAIR PARTS KIT

FIGURE 1B

**PF55518-2 UNIT ASSEMBLY**

NO.	QTY	PART NO.	PART NAME	NO.	QTY	PART NO.	PART NAME
1	1	PF55525	PUMP ASSEMBLY	7	1	422-013	CHECK VALVE
2	1	PF55672	GASKET	8	1	PF55447	FILLPORT ASSEMBLY
3	1	711-018	NIPPLE, 1/4 NPT x 3/8 NPT	9	1	722-014	ELBOW, 3/8 TUBE x 1/4 NPT
4	2	721-009	CONNECTOR, 3/8 T x 1/4 MPT	10	5	323-038	SHCS, 1/4-28 x 1 3/4 LG
5	1	732-002	TUBING, 3/8 OD x .049 WALL	11	1	323-063	SHCS, 1/4-28 x 1" LG
6	1	723-009	TEE, 3/8 T x 3/8 T x 1/4 MPT				

◆ PART OF REPAIR PARTS KIT

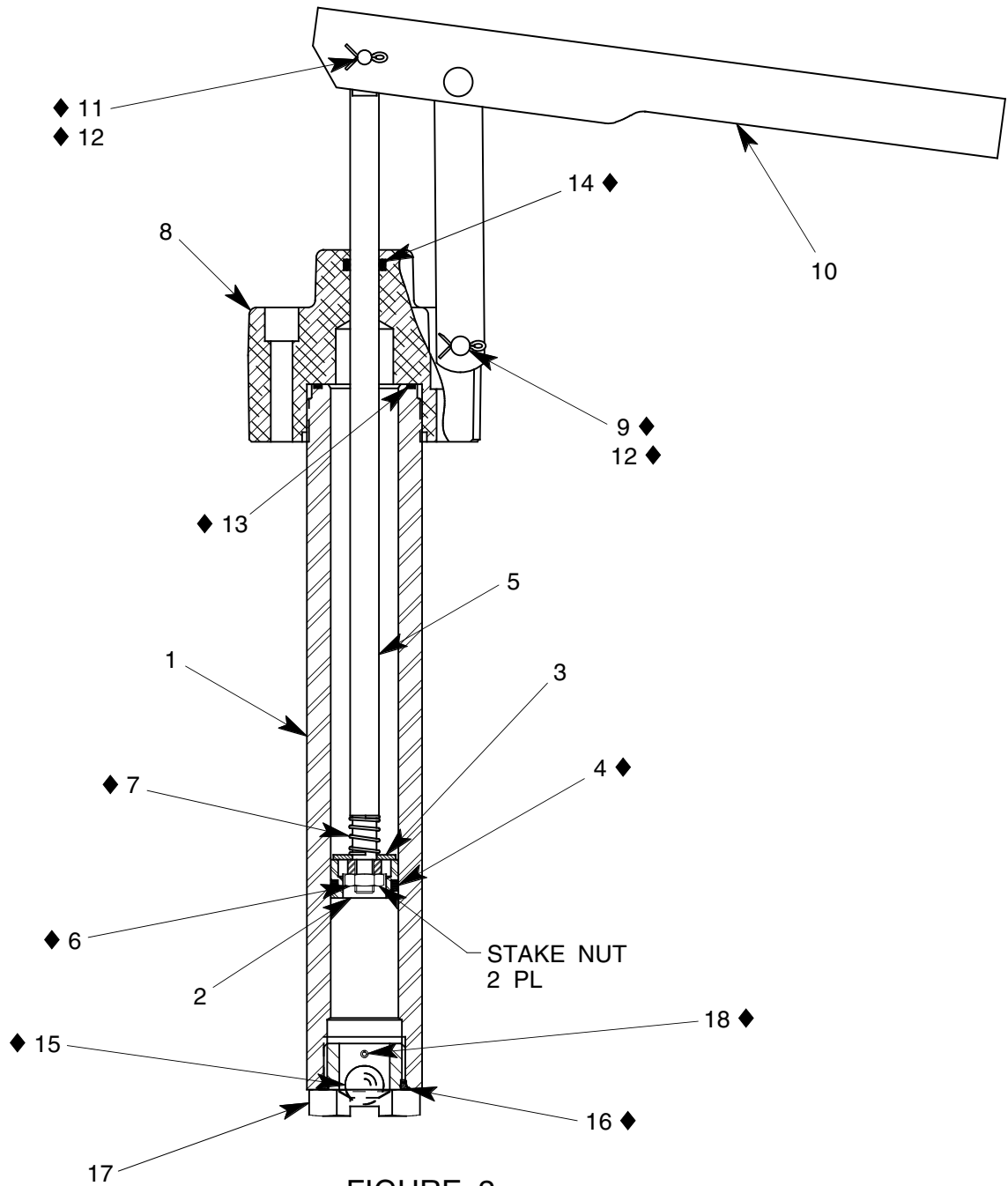
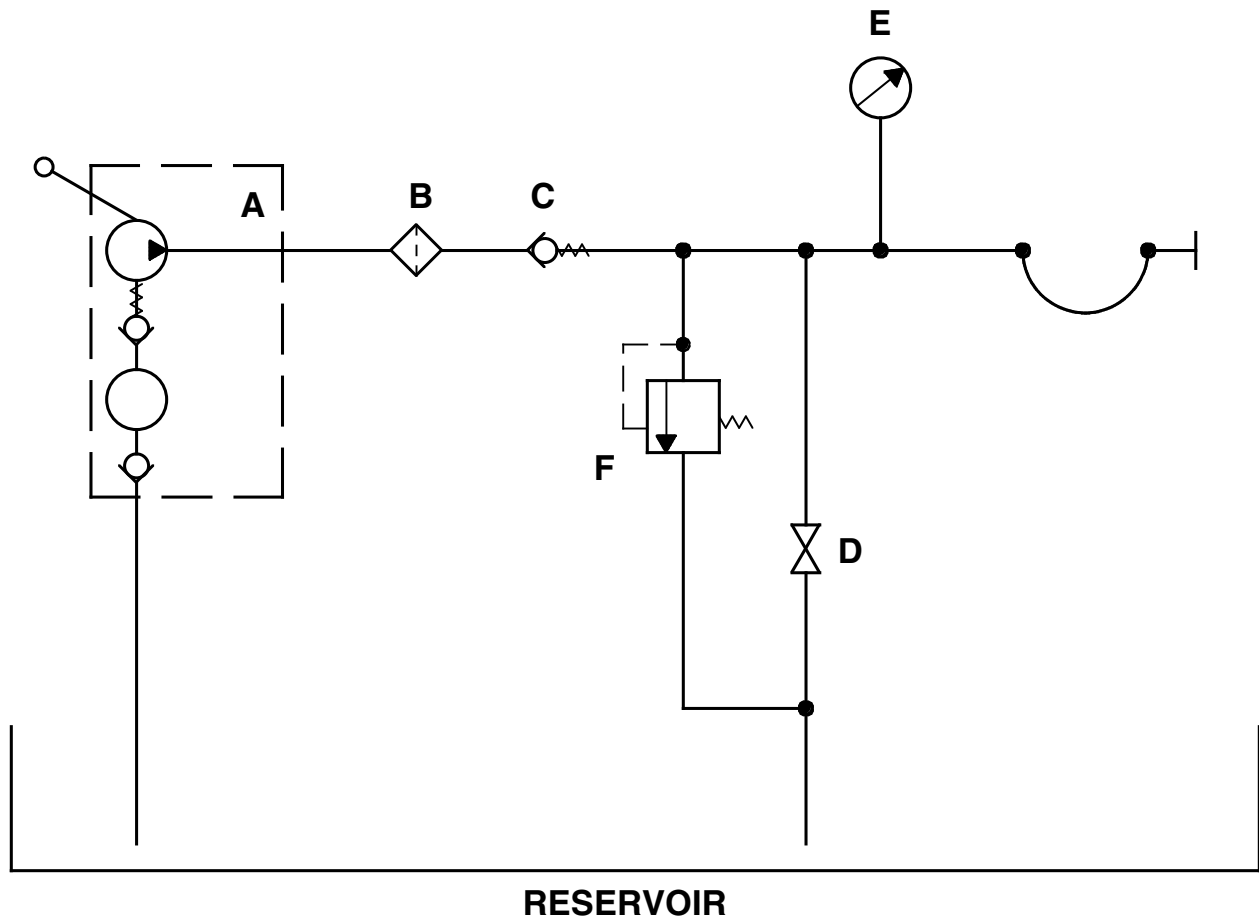

FIGURE 2

**PF55525 PUMP ASSEMBLY**

NO.	QTY	PART NO.	PART NAME	NO.	QTY	PART NO.	PART NAME
1	1	PF55441	PUMP TUBE	10	1	494-017	HANDLE ASSEMBLY
2	1	PF55452	PUMP PISTON	11	1	AN393-17	FH PIN, 3/16 DIA x 17/32 LG
3	1	PF55453	PUMP PISTON DISC	12	2	372-011	COTTER PIN, 1/16 x 1/2 LG
4	1	55925-115	O-RING	13	1	55925-024	O-RING
5	1	PF53378	PUMP PISTON ROD	14	1	55925-110	O-RING
6	1	352-011	HEX JAM NUT, 1/4-28	15	1	412-006	STEEL BALL, 1/2 DIA
7	1	PF53406	SPRING	16	1	55925-912	O-RING
8	1	PF55685	PUMP OUTLET	17	1	PF55442	VALVE BODY
9	1	373-006	FH PIN, 1/4 DIA x 1 9/32 LG	18	1	371-017	ROLL PIN, 3/32 DIA x 7/8 LG



- A - HAND PUMP ASSEMBLY
- B - FILTER
- C - CHECK VALVE
- D - BY-PASS VALVE
- E - GAUGE
- F - RELIEF VALVE

FIGURE 3

**HYDRAULIC DIAGRAM**

**PF2-57PK REPAIR PARTS KIT**

QTY	PART NO.	PART NAME
1	PF55566-2	HOSE ASSEMBLY
1	PF55672	GASKET
1	55925-120	O-RING
1	481-005	FILTER ELEMENT
1	373-006	FLAT HEAD PIN, 1/4 DIA x 1 9/32 LG
2	372-011	COTTER PIN, 1/16 DIA x 1/2 LG
1	AN393-17	FLAT HEAD PIN, 3/16 DIA x 17/32 LG
1	55925-024	O-RING
1	PF53406	SPRING
1	412-006	STEEL BALL, 1/2 DIA
1	55925-110	O-RING
1	55925-912	O-RING
1	55925-115	O-RING
1	352-011	HEX JAM NUT, 1/4-28
1	371-017	ROLL PIN, 3/32 DIA x 7/8 LG
1	PF2-57PKDOC	REPAIR PARTS KIT LIST