

# **MALABAR**

**INTERNATIONAL**

***AIRCRAFT MAINTENANCE & SUPPORT EQUIPMENT***

***OWNER'S MANUAL FOR MALABAR MODEL***

## **PF55966-21PWS**

***2 GALLON FLUID DISPENSER***

***READ  
AND  
SAVE***

**THIS  
INSTRUCTION  
MANUAL**

- \* GENERAL DESCRIPTION
- \* OPERATION
- \* SERVICE
- \* PARTS BREAKDOWN

For Service & Spare  
Parts, Please Contact:

Malabar International  
220 W. Los Angeles Avenue  
Simi Valley, California 93065  
Phone: (805) 581-0116  
Fax: (805) 584-1624  
E-mail: [sales@malabar.com](mailto:sales@malabar.com)  
Web site: <http://www.malabar.com>

***OVER 65 YEARS OF SERVICE & EXPERIENCE***

## GENERAL DESCRIPTION, OPERATION, SERVICE AND PARTS BREAKDOWN

### ***MALABAR MODEL PF55966-21PWS 2 GALLON FLUID DISPENSER***

**CAUTION: AIRCRAFT MANUFACTURER'S SPECIFICATIONS AND INSTRUCTIONS MUST BE FOLLOWED. IN THE EVENT OF CONTRADICTION BETWEEN AIRCRAFT MANUFACTURER'S SPECIFICATIONS AND MALABAR'S, AIRCRAFT MANUFACTURER'S WILL PREVAIL.**

#### **SPECIFICATIONS:**

Fluid -----	TURBO OIL 2197	
Reservoir capacity -----	2 U.S. gal	7.6 liters
Pump outlet pressure -----	100 psig	689 kPa
Volume per stroke-----	2.5 cubic in	41 cc
Relief valve setting-----	125 ± 10 psig	862 ± 69 kPa
Hose length -----	84 in	2134 mm
Net weight (empty)-----	12 lbs	5.4 kg
Filter rating -----	1 micron nominal	
Fluid tank color-----	dark blue	

#### **GENERAL DESCRIPTION:**

The Malabar Model PF55966-21PWS is a 2 gallon fluid dispenser used to service various commercial aircraft. The hand pump dispenser consists of a reservoir, pump assembly, relief valve, water stop filter assembly, and a fluid delivery hose with a coupling.

#### **PREPARATION FOR USE:**

The unit is shipped fully assembled. Fill reservoir at fillport with approved fluid. Operate hand pump assembly a few strokes to bleed all air out of the system. The unit is now ready for use.

## **OPERATION:**

1. Remove dust plug from hose coupling and connect the hose coupling to the aircraft service point.
2. Use full steady pumping strokes when operating pump assembly during replenishing.
3. Disconnect the hose coupling from the aircraft service point, replace the dust plug and store the unit in a dry, dust free location.

## **ILLUSTRATED PARTS LIST:**

Refer to figure 1A & 1B for unit assembly (see sheets 3 & 4), figure 2 for pump assembly (see sheet 5) or figure 3 for filter assembly (see sheet 6).

## **SERVICING:**

1. The frequency of filter change depends on operating conditions. Generally, changes should be made every 3-4 months or sooner if more than normal resistance is felt on the pumping stroke at low pressure. Refer to item 10 in figure 3 (see sheet 6) to change element. Proper element must be installed, otherwise unit will not pump fluid.
2. NOTE: The relief valve should not be removed. The relief valve is set to by-pass oil back to the reservoir at  $125 \pm 10$  PSIG.

## **REPAIR AND REPLACEMENT:**

No definite time schedule can be established for the overhaul of the pump assembly for the replacement of the various moving parts. The number of times the pump assembly is operated materially affect the life of the working parts. The moving piston seal (item 6) and rod seal (item 11) are normally the first to wear (see sheet 5). This is usually indicated by leakage of fluid past the piston or rod. It is advisable to change piston seal (item 6), rod seal (item 11) and gasket (item 16) immediately if leakage is discovered. A repair parts kit (P/N PF2-41PK) is available and recommended to keep on hand at your facility. Refer to sheet 7 for the complete list of parts contained in the repair parts kit.

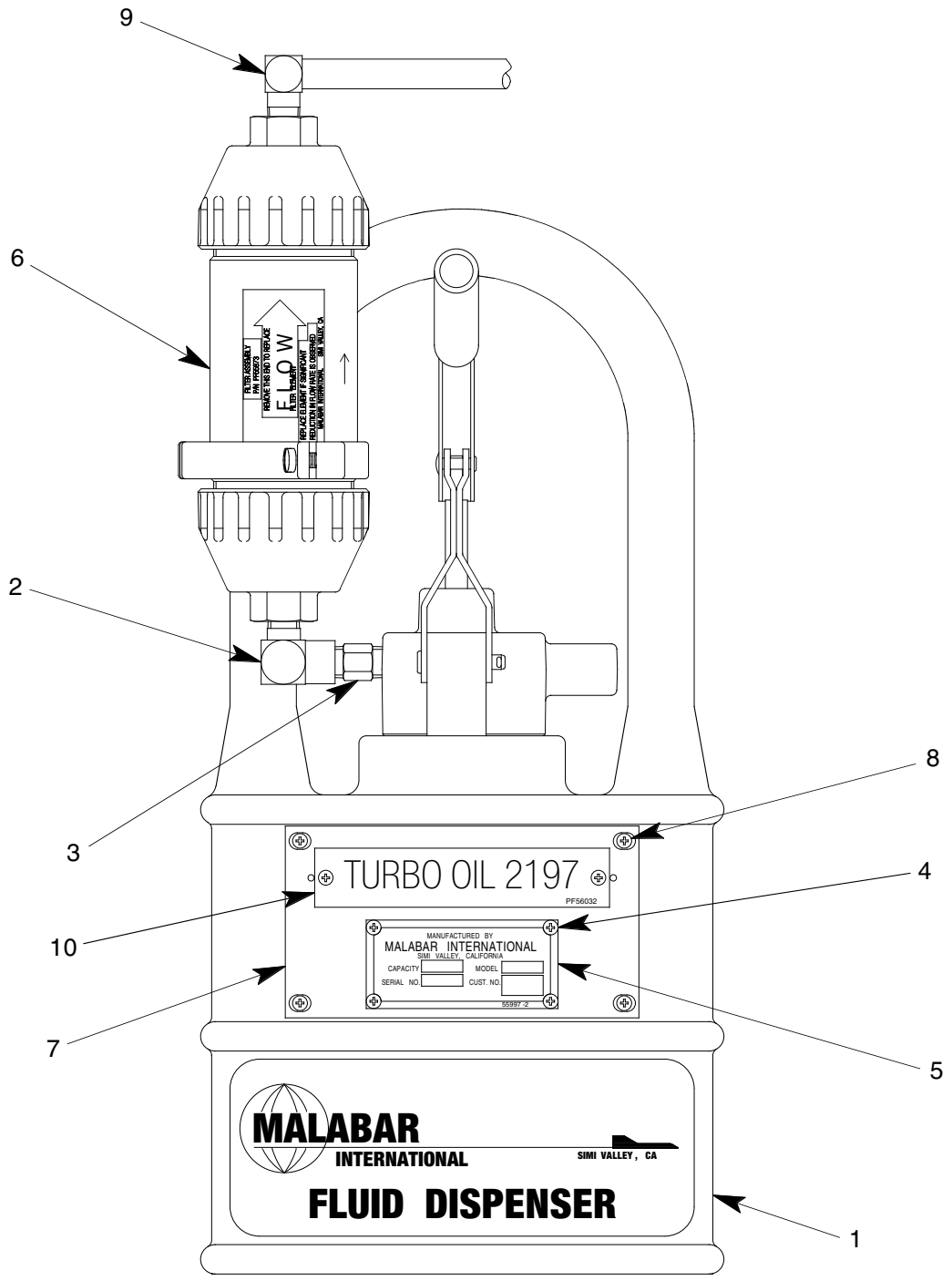
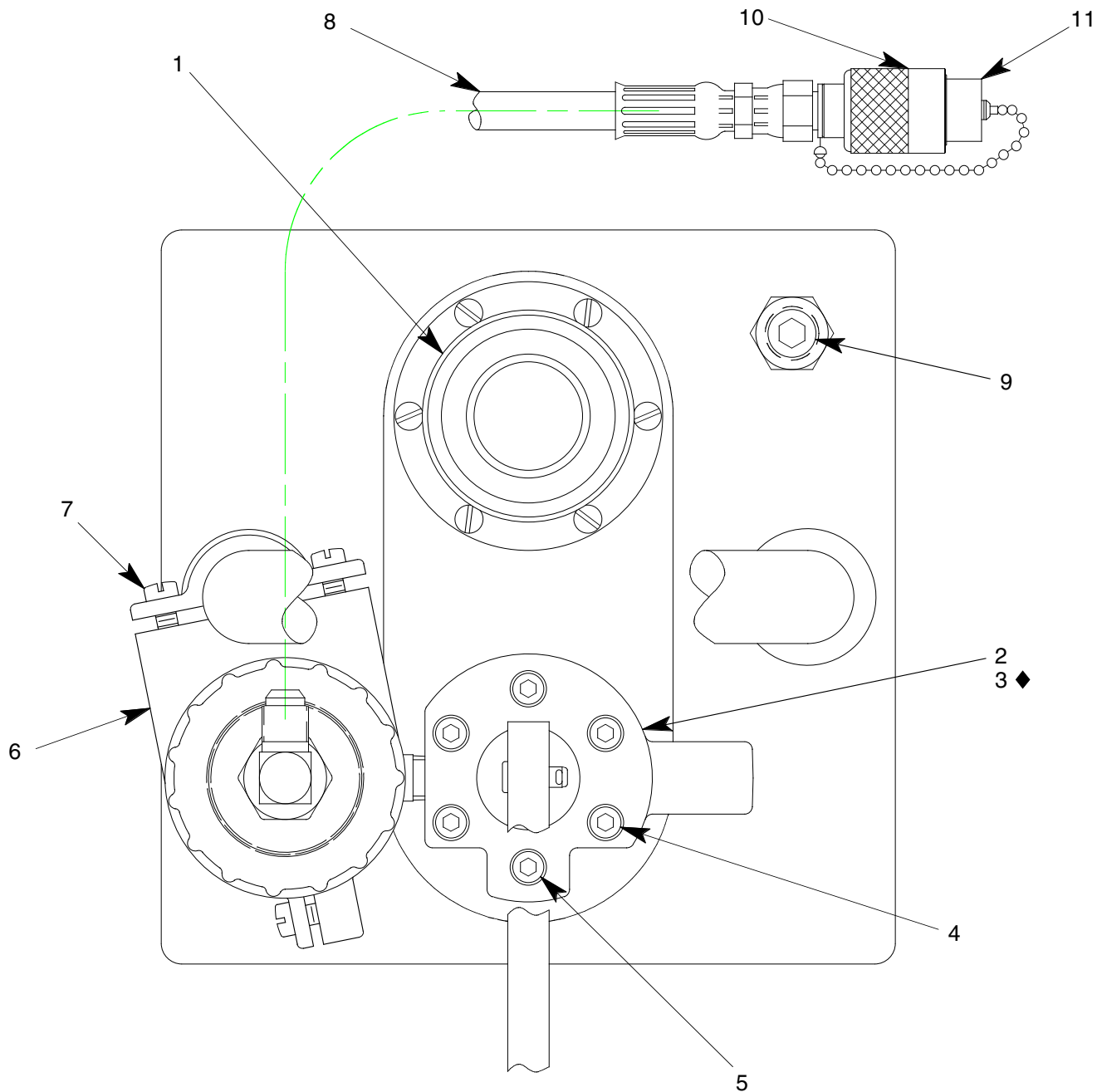

FIGURE 1A

**PF55966-21PWS UNIT ASSEMBLY**

NO.	QTY	PART NO.	PART NAME	NO.	QTY	PART NO.	PART NAME
1	1	PF55838-5	FLUID TANK	6	1	PF55873	FILTER ASSEMBLY
2	1	712-008	ELBOW, STREET, 1/4 NPT	7	1	PF55859	PLACARD PLATE
3	1	711-047	NIPPLE, HEX, 1/4 NPT x 1 1/2	8	4	344-011	FHMS, 6-32 x 7/16 LG
4	6	397-010	SELF TAPPING SCREW, 6-32	9	1	722-005	ELBOW, 3/8 37° x 1/4 NPT
5	1	55997-2	NAMEPLATE	10	1	PF56032	PLACARD, TURBO OIL 2197



◆ PART OF REPAIR PARTS KIT

FIGURE 1B

**PF55966-21PWS UNIT ASSEMBLY**

NO.	QTY	PART NO.	PART NAME	NO.	QTY	PART NO.	PART NAME
1	1	PF55447	FILLPORT ASSEMBLY	7	3	342-010	SCREW, FIL HD, 1/4-20 x 1" LG
2	1	PF55845-1	PUMP ASSEMBLY	8	1	PF55456-1	HOSE ASSEMBLY
3	1	PF55672	GASKET	9	1	717-007	PLUG, 3/8 NPT
4	5	323-038	SHCS, 1/4-28 x 1 3/4 LG	10	1	736-013	COUPLING
5	1	323-063	SHCS, 1/4-28 x 1" LG	11	1	PF55987	DUST PLUG AND CHAIN
6	1	PF55871-1	YOKE CLAMP				

◆ PART OF REPAIR PARTS KIT

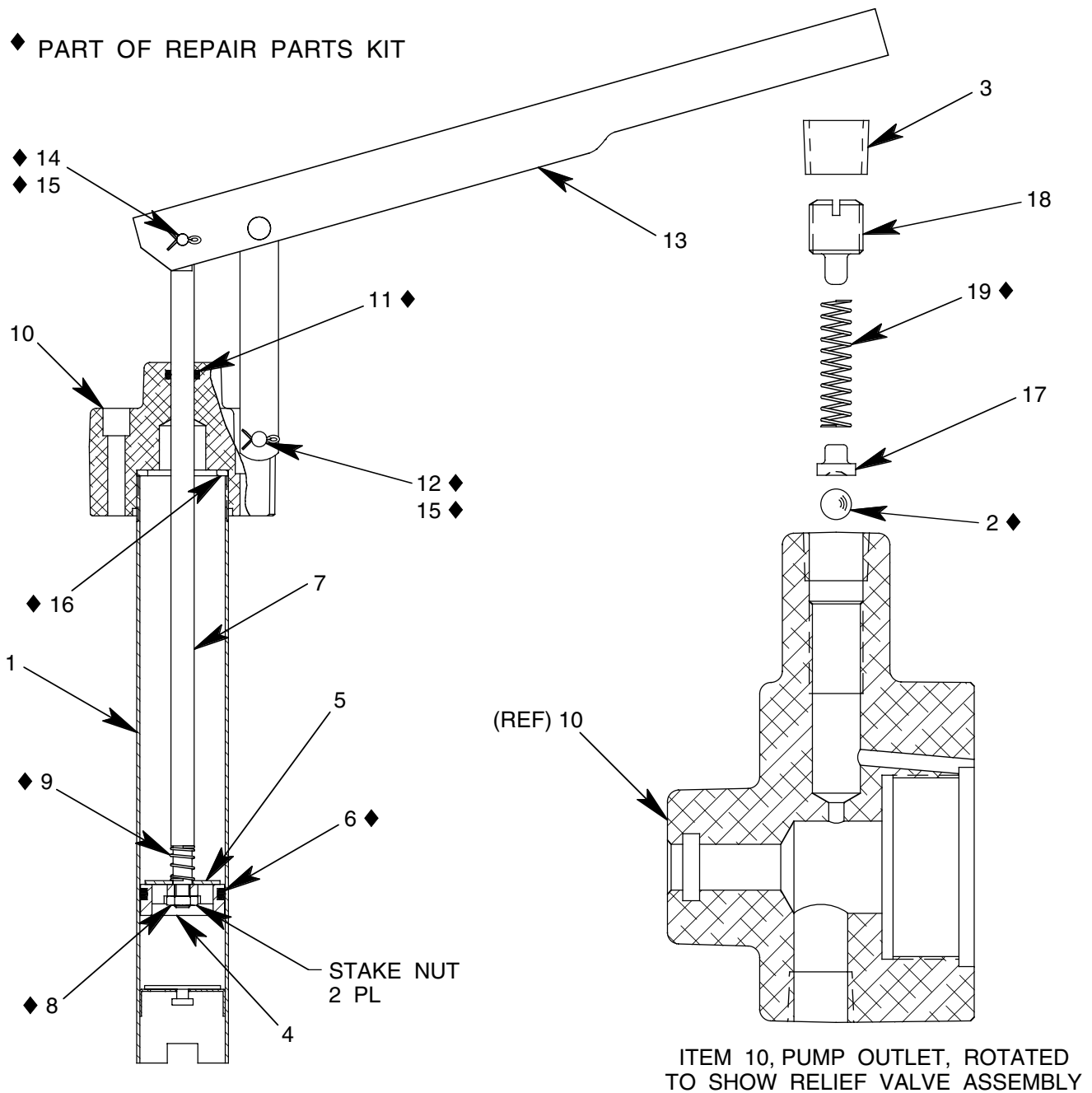
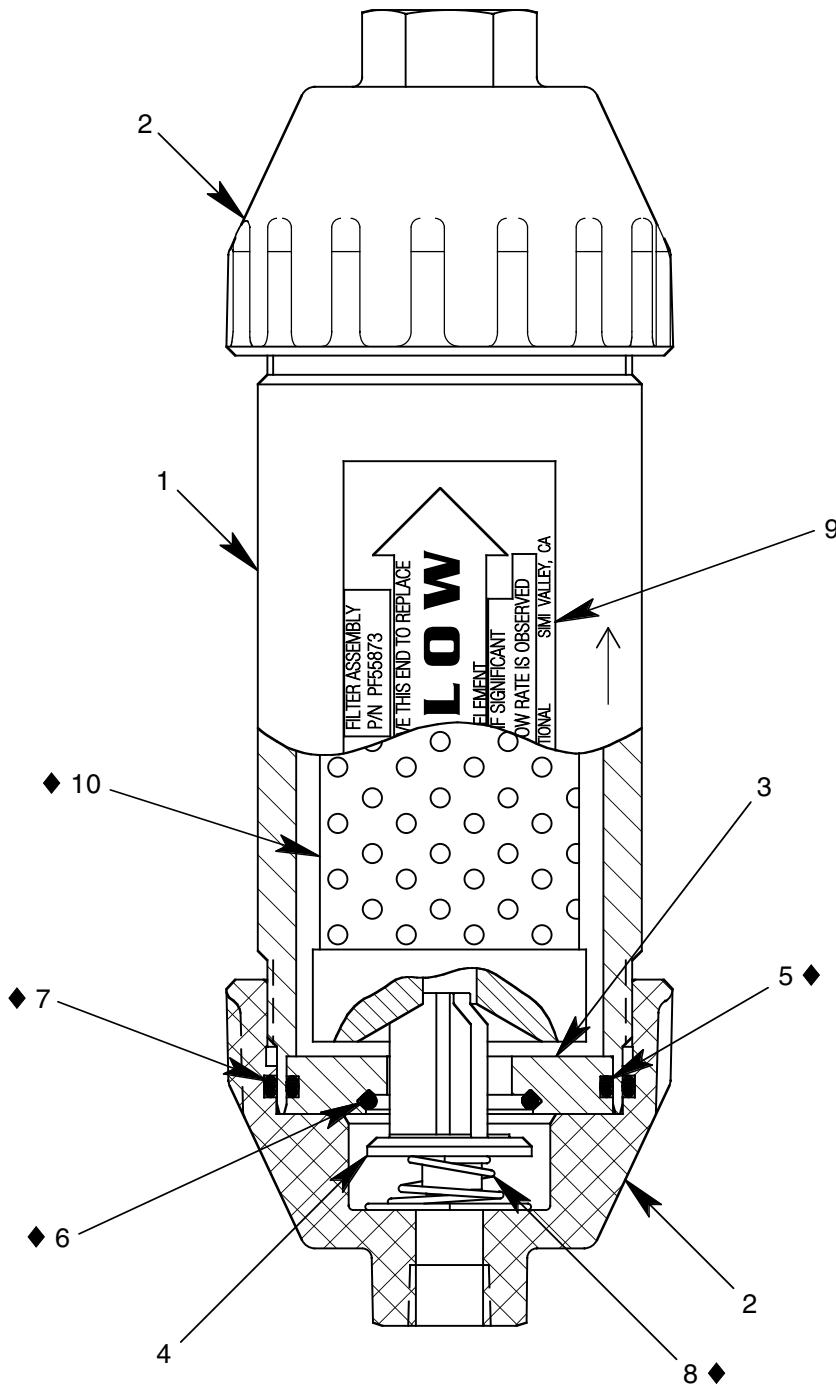

FIGURE 2

**PF55845-1 PUMP ASSEMBLY**

NO.	QTY	PART NO.	PART NAME	NO.	QTY	PART NO.	PART NAME
1	1	PF53376	TUBE ASSEMBLY	11	1	55925-110	O-RING
2	1	412-004	STEEL BALL, 1/4 DIA	12	1	373-006	FH PIN, 1/4 DIA x 1 9/32 LG
3	1	717-006	PLUG, 1/4 NPT	13	1	494-017	HANDLE ASSEMBLY
4	1	PF53379	PISTON	14	1	AN393-17	FH PIN, 3/16 DIA x 17/32 LG
5	1	PF53380	PISTON CHECK DISC	15	2	372-011	COTTER PIN, 1/16 x 1/2 LG
6	1	55925-216	O-RING	16	1	PF54063	GASKET
7	1	PF53378	PUMP PISTON ROD	17	1	55153	SPRING GUIDE
8	1	352-011	HEX JAM NUT, 1/4-28	18	1	55148	SET SCREW
9	1	PF53406	SPRING	19	1	495-038	SPRING
10	1	PF55820-1	PUMP OUTLET				



◆ PART OF REPAIR PARTS KIT

FIGURE 3

**PF55873 FILTER ASSEMBLY**

NO.	QTY	PART NO.	PART NAME	NO.	QTY	PART NO.	PART NAME
1	1	PF55849	FILTER HOUSING	6	1	55925-120	O-RING
2	2	PF55852	FILTER HOUSING END CAP	7	2	55925-140	O-RING
3	1	PF55853	RETAINER DISC	8	1	495-039	SPRING
4	1	PF55850	RETAINER VALVE	9	1	PF55872	DECAL, FLOW
5	1	55925-135	O-RING	10	1	481-068	FILTER ELEMENT

**PF2-41PK REPAIR PARTS KIT**

QTY	PART NO.	PART NAME
1	PF55456-1	HOSE ASSEMBLY
1	55925-216	O-RING
1	55925-110	O-RING
1	PF53406	SPRING
1	373-006	FLAT HEAD PIN, 1/4 DIA x 1 9/32 LG
2	372-011	COTTER PIN, 1/16 x 1/2 LG
1	AN393-17	FLAT HEAD PIN, 3/16 DIA x 17/32 LG
1	PF54063	GASKET
1	495-038	SPRING
1	412-004	STEEL BALL, 1/4 DIA
1	55925-135	O-RING
1	55925-120	O-RING
2	55925-140	O-RING
1	495-039	SPRING
1	481-068	FILTER ELEMENT
1	352-011	HEX JAM NUT, 1/4-28
1	PF55672	GASKET
1	PF2-41PKDOC	REPAIR PARTS KIT LIST