

# **MALABAR**

**INTERNATIONAL**

***AIRCRAFT MAINTENANCE & SUPPORT EQUIPMENT***

***OWNER'S MANUAL FOR MALABAR MODEL***

## **PF55966-3P**

***2 GALLON FLUID DISPENSER***

***READ  
AND  
SAVE***

**THIS  
INSTRUCTION  
MANUAL**

- \* GENERAL DESCRIPTION
- \* OPERATION
- \* SERVICE
- \* PARTS BREAKDOWN

For Service & Spare  
Parts, Please Contact:

Malabar International  
220 W. Los Angeles Avenue  
Simi Valley, California 93065  
Phone: (805) 581-0116  
Fax: (805) 584-1624  
E-mail: [sales@malabar.com](mailto:sales@malabar.com)  
Web site: <http://www.malabar.com>

***OVER 65 YEARS OF SERVICE & EXPERIENCE***

**GENERAL DESCRIPTION, OPERATION, SERVICE AND PARTS BREAKDOWN**

***MALABAR MODEL PF55966-3P  
2 GALLON FLUID DISPENSER***

**CAUTION: AIRCRAFT MANUFACTURER'S SPECIFICATIONS AND INSTRUCTIONS MUST BE FOLLOWED. IN THE EVENT OF CONTRADICTION BETWEEN AIRCRAFT MANUFACTURER'S SPECIFICATIONS AND MALABAR'S, AIRCRAFT MANUFACTURER'S WILL PREVAIL.**

**SPECIFICATIONS:**

Fluid -----	MOBIL JET II	
Reservoir capacity -----	2 U.S. gal	7.6 liters
Pump outlet pressure -----	100 psig	689 kPa
Volume per stroke-----	2.5 cubic in	41 cc
Hose length-----	84 in	2134 mm
Net weight (empty)-----	12 lbs	5.4 kg
Filter rating-----	3 micron nominal	
Fluid tank color-----	dark blue	

**GENERAL DESCRIPTION:**

The Malabar Model PF55966-3P is a 2 gallon fluid dispenser used to service various commercial aircraft. The hand pump dispenser consists of a reservoir, pump assembly, filter assembly, and a fluid delivery hose.

**PREPARATION FOR USE:**

The unit is shipped fully assembled. Fill reservoir at fillport with approved fluid. Operate hand pump assembly a few strokes to bleed all air out of the system. The unit is now ready for use.

**OPERATION:**

1. Connect the hose to the aircraft service point.
2. Use full steady pumping strokes when operating pump assembly during replenishing.
3. Disconnect the hose from the aircraft service point and store the unit in a dry, dust free location.

**ILLUSTRATED PARTS LIST:**

Refer to figure 1A & 1B for unit assembly (see sheets 3 & 4) or figure 2 for pump assembly (see sheet 5).

**SERVICING:**

1. The frequency of filter change depends on operating conditions. Generally, changes should be made every 3-4 months or sooner if more than normal resistance is felt on the pumping stroke at low pressure. Refer to item 8 in figure 1A (see sheet 3) to change element.

**REPAIR AND REPLACEMENT:**

No definite time schedule can be established for the overhaul of the pump assembly for the replacement of the various moving parts. The number of times the pump assembly is operated materially affect the life of the working parts. The moving piston seal (item 4) and rod seal (item 14) are normally the first to wear (see sheet 5). This is usually indicated by leakage of fluid past the piston or rod. It is advisable to change piston seal (item 4), rod seal (item 14) and gasket (item 13) immediately if leakage is discovered. A repair parts kit (P/N PF2-4PK) is available and recommended to keep on hand at your facility. Refer to sheet 6 for the complete list of parts contained in the repair parts kit.

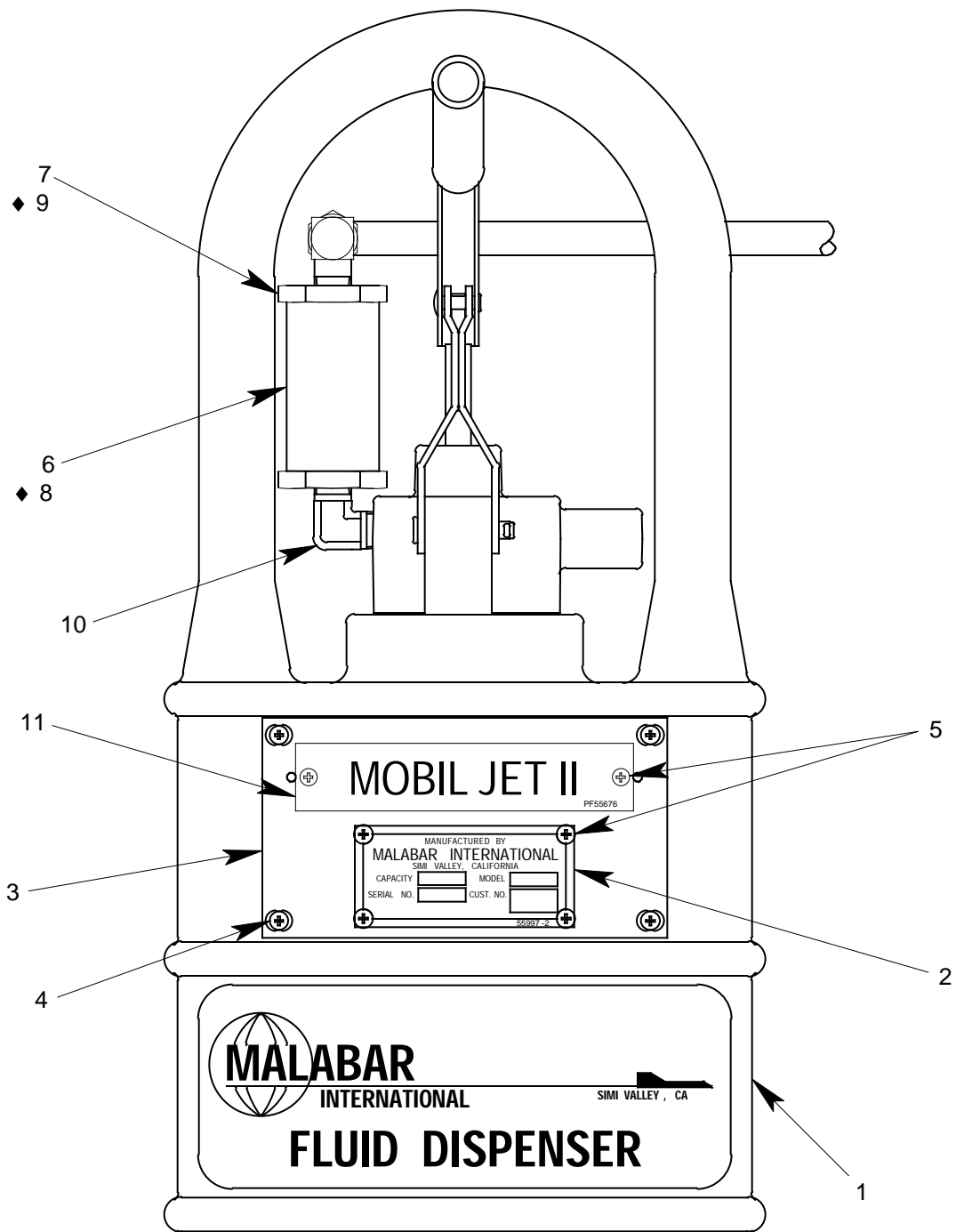

◆ PART OF REPAIR PARTS KIT

FIGURE 1A

**PF55966-3P UNIT ASSEMBLY**

NO.	QTY	PART NO.	PART NAME	NO.	QTY	PART NO.	PART NAME
1	1	PF55838-5	FLUID TANK	7	1	PF712722	FILTER RETAINER
2	1	55997-2	NAMEPLATE	8	1	481-005	FILTER ELEMENT
3	1	PF55859	PLACARD PLATE	9	1	55925-120	O-RING
4	4	344-011	FHMS, 6-32 x 7/16 LG	10	1	712-022	ELBOW, 1/4 NPT
5	6	397-010	SELF TAPPING SCREW, 6-32	11	1	PF55676	PLACARD, MOBIL JET II
6	1	PF712721	FILTER BODY				

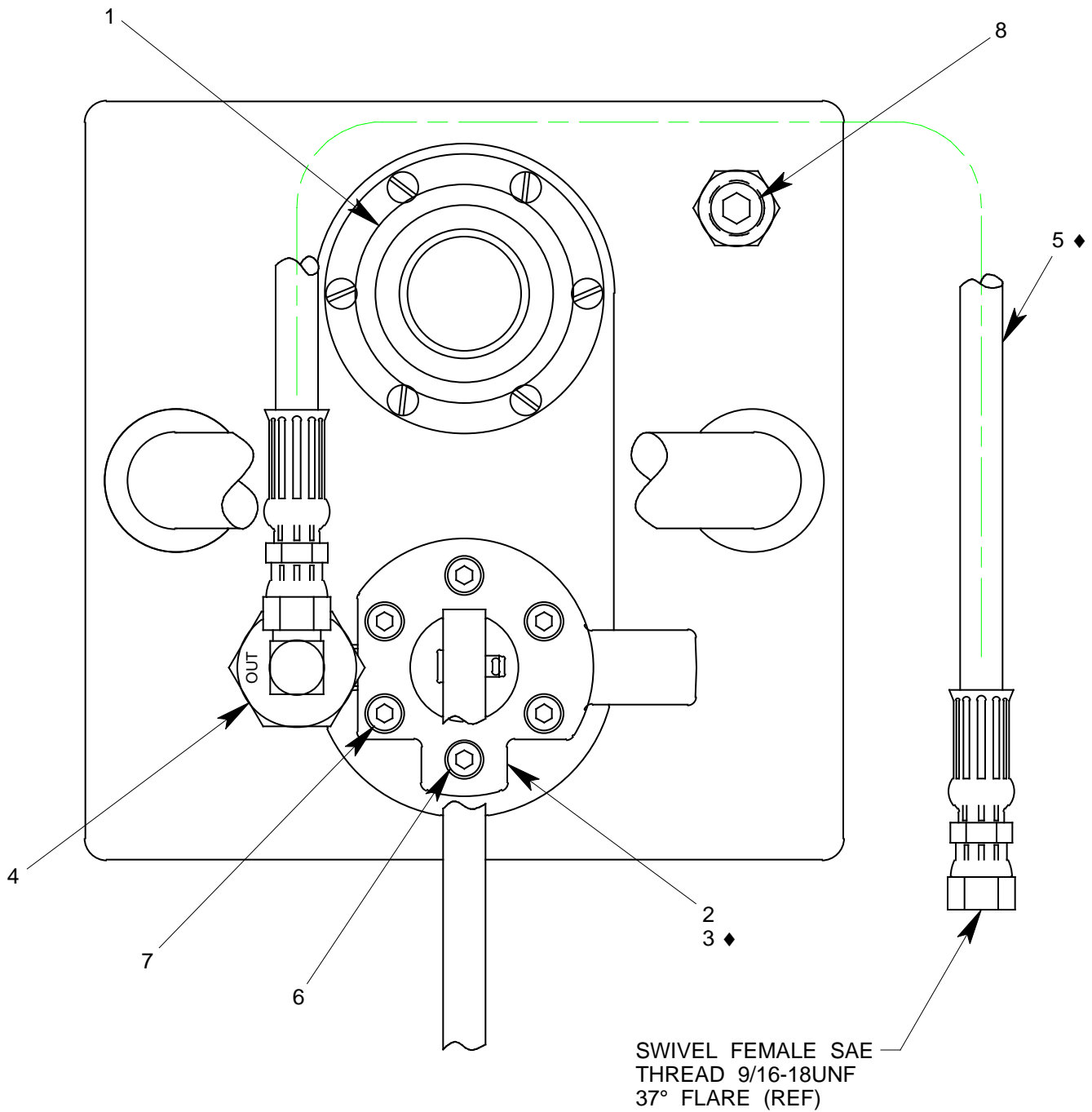

◆ PART OF REPAIR PARTS KIT

FIGURE 1B

**PF55966-3P UNIT ASSEMBLY**

NO.	QTY	PART NO.	PART NAME	NO.	QTY	PART NO.	PART NAME
1	1	PF55447	FILLPORT ASSEMBLY	5	1	PF55456-1	HOSE ASSEMBLY
2	1	PF53415A-1	PUMP ASSEMBLY	6	1	323-063	SHCS, 1/4-28 x 1" LG
3	1	PF55672	GASKET	7	5	323-038	SHCS, 1/4-28 x 1 3/4 LG
4	1	722-005	ELBOW, 3/8 37° x 1/4 NPT	8	1	717-007	PLUG, 3/8 NPT

◆ PART OF REPAIR PARTS KIT

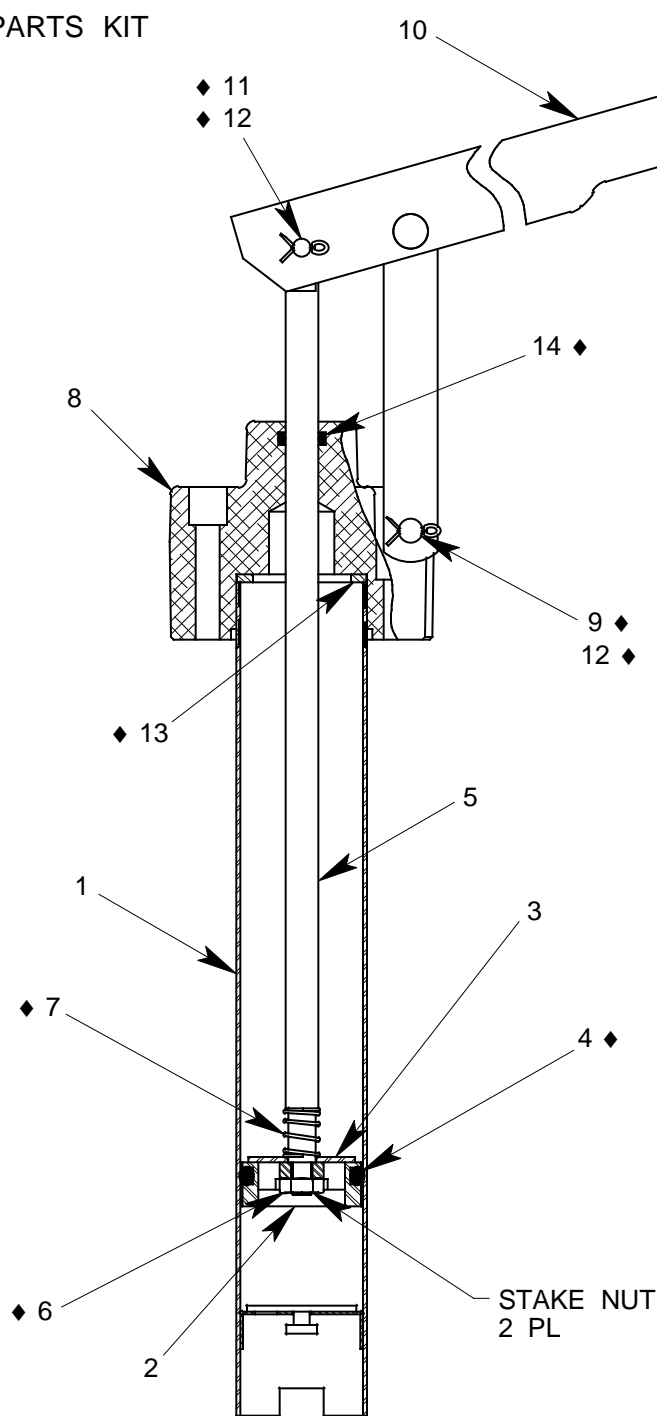

FIGURE 2

**PF53415A-1 PUMP ASSEMBLY**

NO.	QTY	PART NO.	PART NAME	NO.	QTY	PART NO.	PART NAME
1	1	PF53376	TUBE ASSEMBLY	8	1	PF55685	PUMP OUTLET
2	1	PF53379	PISTON	9	1	373-006	FH PIN, 1/4 DIA x 1 9/32 LG
3	1	PF53380	PISTON CHECK DISC	10	1	494-017	HANDLE ASSEMBLY
4	1	55925-216	O-RING	11	1	AN393-17	FH PIN, 3/16 DIA x 17/32 LG
5	1	PF53378	PUMP PISTON ROD	12	2	372-011	COTTER PIN, 1/16 x 1/2 LG
6	1	352-011	HEX JAM NUT, 1/4-28	13	1	PF54063	GASKET
7	1	PF53406	SPRING	14	1	55925-110	O-RING

**PF2-4PK REPAIR PARTS KIT**

QTY	PART NO.	PART NAME
1	PF55456-1	HOSE ASSEMBLY
1	481-005	FILTER ELEMENT
1	55925-120	O-RING
1	PF55672	GASKET
1	PF53406	SPRING
1	AN393-17	FLAT HEAD PIN, 3/16 DIA x 17/32 LG
1	352-011	HEX JAM NUT, 1/4-28
2	372-011	COTTER PIN, 1/16 DIA x 1/2 LG
1	373-006	FLAT HEAD PIN, 1/4 DIA x 1 9/32 LG
1	55925-216	O-RING
1	55925-110	O-RING
1	PF54063	GASKET
1	PF2-4PKDOC	REPAIR PARTS KIT LIST