

Date: March 4, 1998

MALABAR

INTERNATIONAL

AIRCRAFT MAINTENANCE & SUPPORT EQUIPMENT

OWNER'S MANUAL FOR MALABAR MODEL

PF53467P

5 GALLON FLUID DISPENSER

***READ
AND
SAVE***

**THIS
INSTRUCTION
MANUAL**

- * GENERAL DESCRIPTION
- * OPERATION
- * SERVICE
- * PARTS BREAKDOWN

For Service & Spare
Parts, Please Contact:

Malabar International
220 W. Los Angeles Avenue
Simi Valley, California 93062
Phone: (805) 581-0116
Fax: (805) 584-1624
E-mail: sales@malabar.com

OVER 50 YEARS OF SERVICE & EXPERIENCE

© 1998 Malabar International. All rights reserved. Permission to reproduce all or part of this material must be obtained from Malabar International.

GENERAL DESCRIPTION, OPERATION, SERVICE AND PARTS BREAKDOWN

MALABAR MODEL PF53467P 5 GALLON FLUID DISPENSER

CAUTION: AIRCRAFT MANUFACTURER'S SPECIFICATIONS AND INSTRUCTIONS MUST BE FOLLOWED. IN THE EVENT OF CONTRADICTION BETWEEN AIRCRAFT MANUFACTURER'S SPECIFICATIONS AND MALABAR'S, AIRCRAFT MANUFACTURER'S WILL PREVAIL.

SPECIFICATIONS:

Fluid	SKYDROL 500	
Reservoir capacity	5 U.S. gal	18.9 liters
Pump outlet pressure	100 psig	689 kPa
Volume per stroke	3.0 cubic in	49 cc
Hose length	120 in	3048 mm
Net weight (empty)	35 lbs	15.9 kg
Filter rating	3 micron nominal	
Fluid tank color	purple	

GENERAL DESCRIPTION:

The Malabar Model PF53467P is a 5 gallon fluid dispenser used to service various commercial aircraft. The hand pump dispenser consists of a reservoir, pump assembly, filter assembly, and a fluid delivery hose with a coupling.

PREPARATION FOR USE:

The unit is shipped fully assembled. Fill reservoir at fillport with approved fluid. Operate hand pump assembly a few strokes to bleed all air out of the system. The unit is now ready for use.

OPERATION:

1. Connect the hose coupling to the aircraft service point.
2. Use full steady pumping strokes when operating pump assembly during replenishing.
3. Disconnect the hose coupling from the aircraft service point and store the unit in a dry, dust free location.

ILLUSTRATED PARTS LIST:

Refer to figure 1A, 1B & 1C for unit assembly (see sheets 3, 4 & 5) or figure 2 for pump assembly (see sheet 6).

SERVICING:

1. The frequency of filter change depends on operating conditions. Generally, changes should be made every 3-4 months or sooner if more than normal resistance is felt on the pumping stroke at low pressure. Refer to item 7 in figure 1A (see sheet 3) to change element.

REPAIR AND REPLACEMENT:

No definite time schedule can be established for the overhaul of the pump assembly for the replacement of the various moving parts. The number of times the pump assembly is operated materially affect the life of the working parts. The moving piston seal (item 14) and rod seal (item 15) are normally the first to wear (see sheet 6). This is usually indicated by leakage of fluid past the piston or rod. It is advisable to change piston seal (item 14) and rod seal (item 15) immediately if leakage is discovered. A repair parts kit (P/N PF5-1PK) is available and recommended to keep on hand at your facility. Refer to sheet 7 for the complete list of parts contained in the repair parts kit.

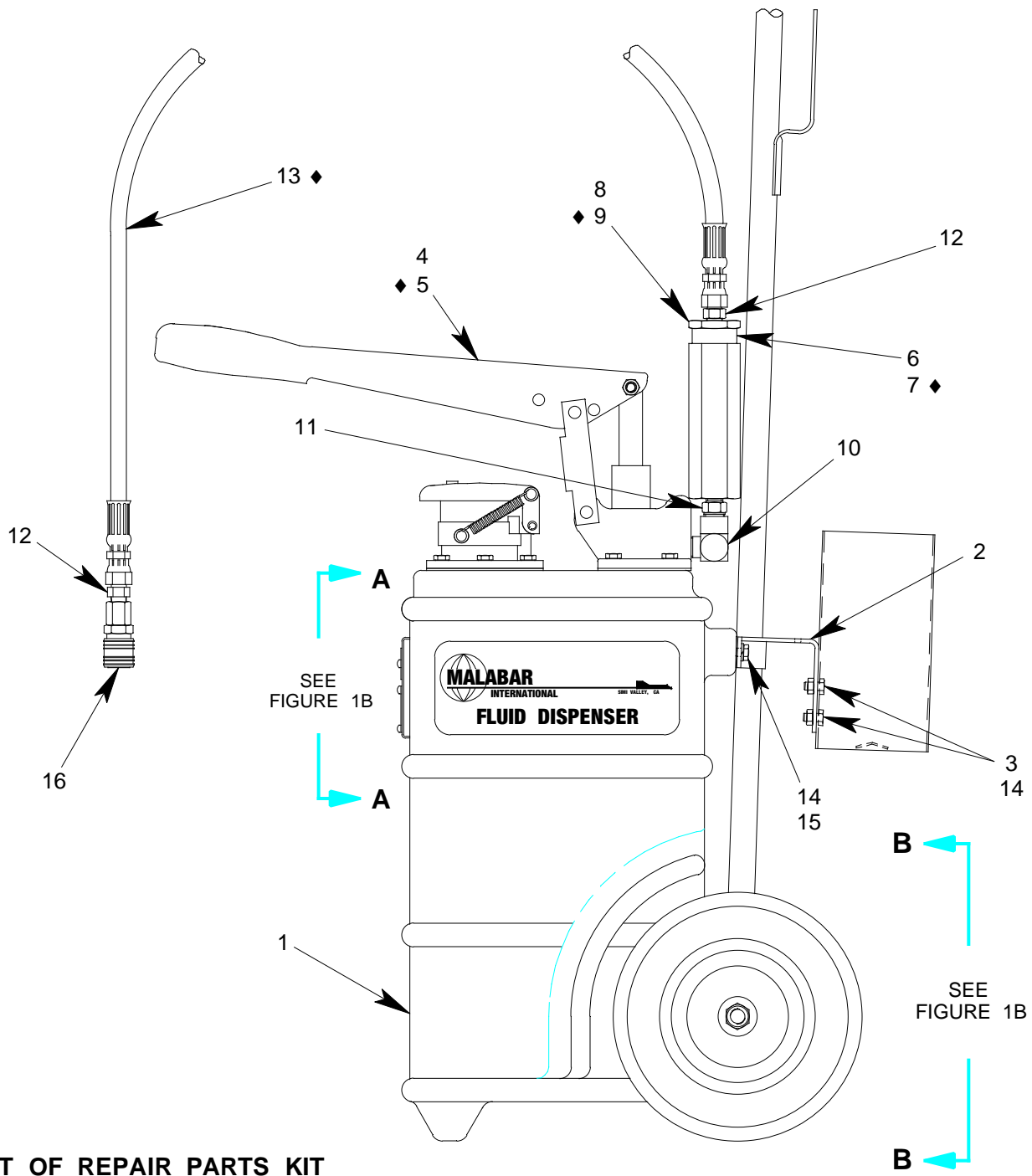

◆ PART OF REPAIR PARTS KIT

FIGURE 1A

PF53467P UNIT ASSEMBLY

NO.	QTY	PART NO.	PART NAME	NO.	QTY	PART NO.	PART NAME
1	1	PF55836-2	FLUID TANK	9	1	55930-025	O-RING
2	1	PF55865	HANDLE SUPPORT WELD	10	1	712-017	ELBOW, STREET, 3/8 NPT
3	2	355-007	NUT, SELF LOCK, 1/4-28	11	1	711-030	NIPPLE, 1/4 NPT x 3/8 NPT
4	1	PF55480-1	PUMP ASSEMBLY	12	2	721-004	CONNECTOR, 3/8 37° x 1/4 NPT
5	1	PF53602	GASKET, PUMP	13	1	PF55470	HOSE ASSEMBLY
6	1	PF101161	BODY, FILTER HOUSING	14	2	329-007	HHCS, 1/4-28 x 21/32 LG
7	1	481-008	FILTER ELEMENT	15	2	363-001	SPLIT LOCKWASHER, 1/4
8	1	PF101163	END CAP, FILTER HOUSING	16	1	716-022	COUPLING

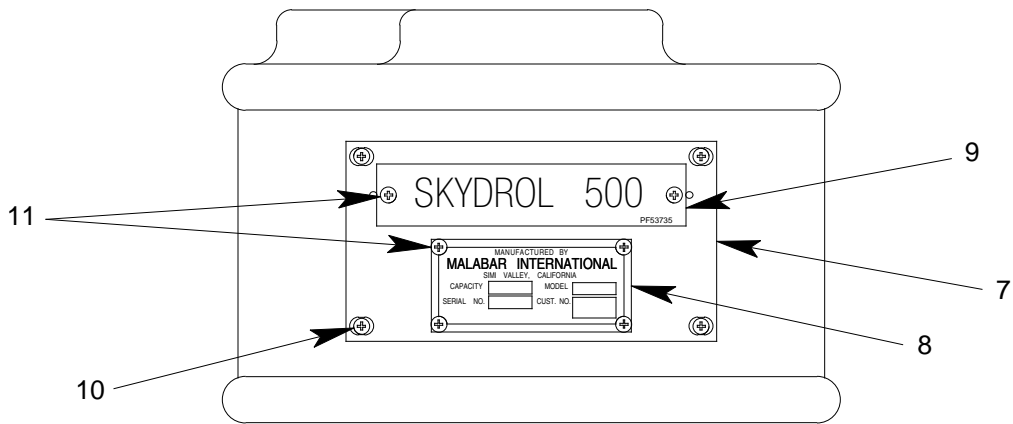

VIEW A-A

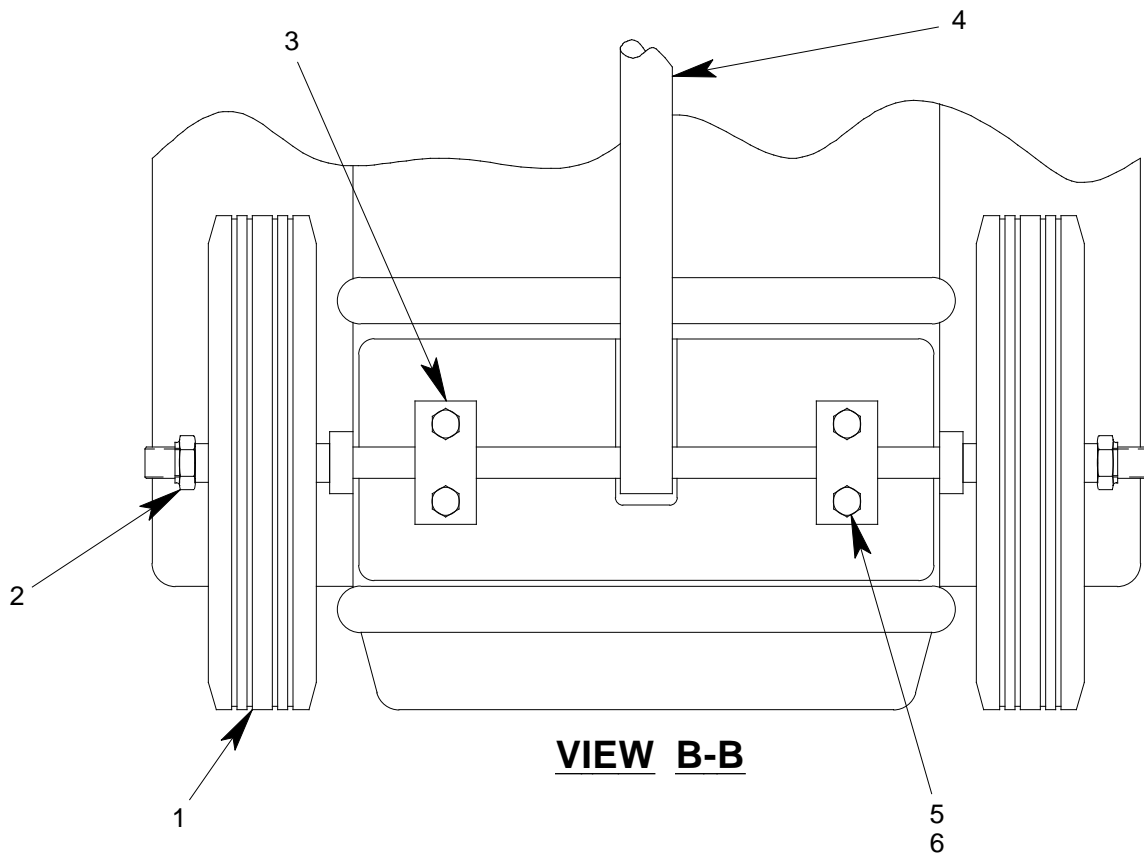

VIEW B-B

FIGURE 1B

PF53467P UNIT ASSEMBLY

NO.	QTY	PART NO.	PART NAME	NO.	QTY	PART NO.	PART NAME
1	2	PF53240	WHEEL	7	1	PF55859	PLACARD PLATE
2	2	355-013	LOCKNUT	8	1	55997-2	NAMEPLATE
3	2	PF55858	SUPPORT STRAP	9	1	PF53735	PLACARD
4	1	PF55841	AXLE-HANDLE WELDMENT	10	4	344-011	FHMS, 6-32 x 7/16 LG
5	4	329-007	HHCS, 1/4-28 x 21/32 LG	11	6	397-010	SELF TAPPING SCREW, 6-32
6	4	363-001	SPLIT LOCKWASHER, 1/4				

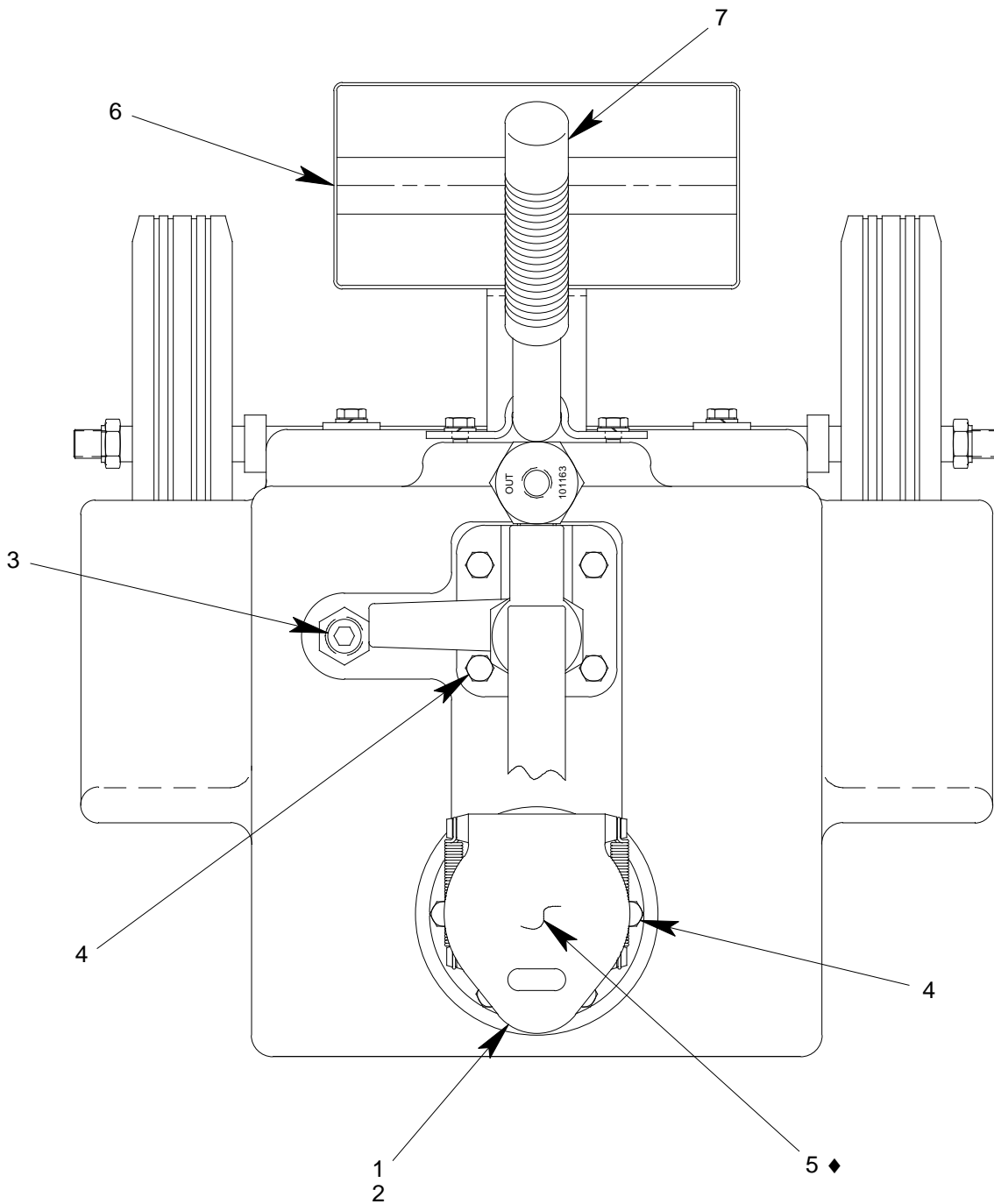

◆ PART OF REPAIR PARTS KIT

FIGURE 1C

PF53467P UNIT ASSEMBLY

NO.	QTY	PART NO.	PART NAME	NO.	QTY	PART NO.	PART NAME
1	1	PF53549	FILLPORT ASSEMBLY	5	1	55930-329	O-RING
2	1	PF53628	GASKET, FILLPORT	6	1	PF53842	BOX
3	1	717-007	PLUG, 3/8 NPT	7	1	494-006	HANDLE GRIP
4	10	329-007	HHCS, 1/4-28 x 21/32 LG				

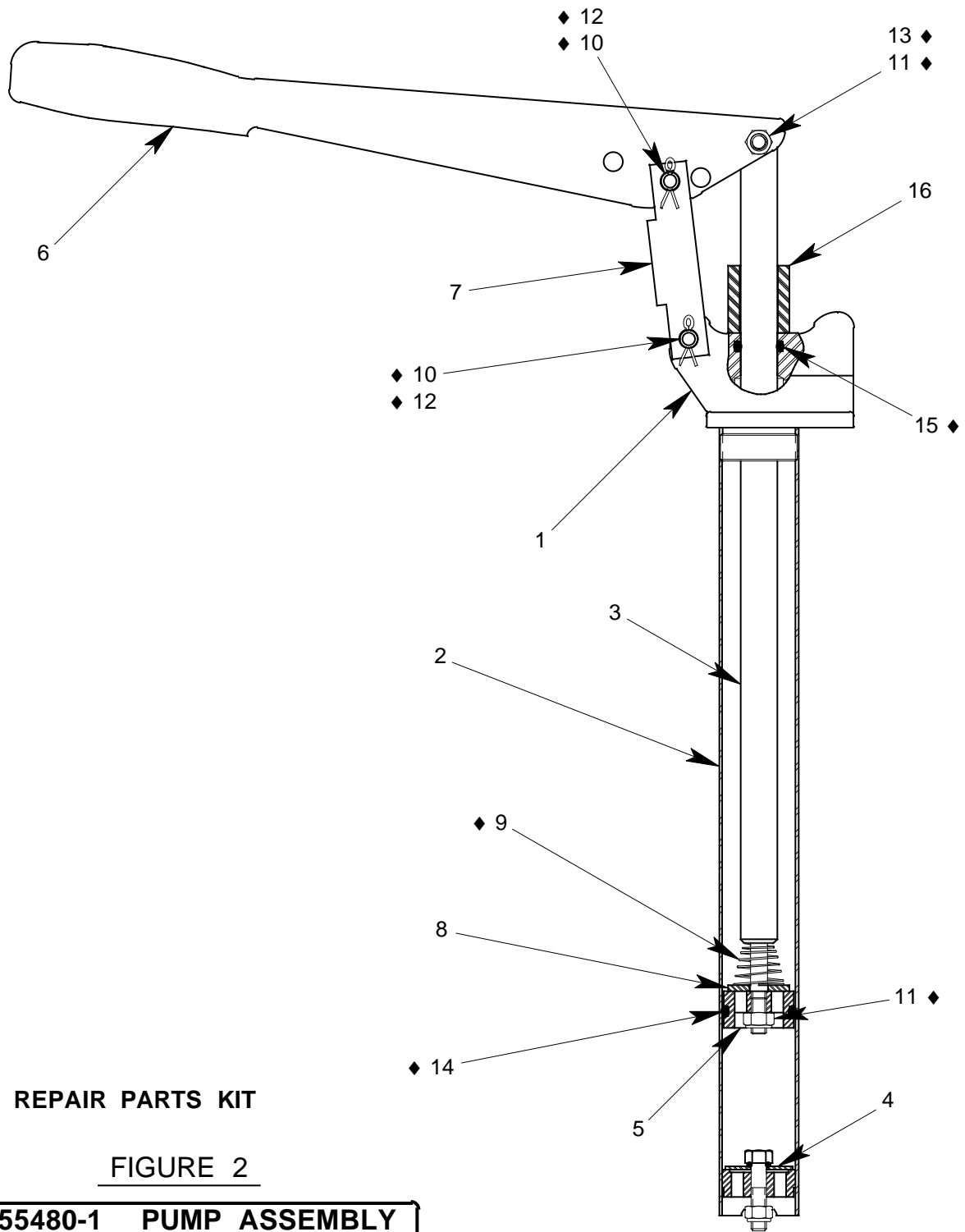

◆ PART OF REPAIR PARTS KIT

FIGURE 2

PF55480-1 PUMP ASSEMBLY

NO.	QTY	PART NO.	PART NAME	NO.	QTY	PART NO.	PART NAME
1	1	PF55466	PUMP BODY	9	1	PF53600	SPRING
2	1	PF53514	TUBE	10	2	PF53518	PIN
3	1	PF53515	PLUNGER ROD	11	2	355-021	SELF LOCK NUT, 5/16-24
4	1	PF53594	VALVE ASSEMBLY	12	2	372-001	COTTER PIN, 3/32 x 3/4 LG
5	1	PF53599	PLUNGER BODY	13	1	AN5-12A	HHCS, 5/16-24 x 1 11/32
6	1	PF53517	HANDLE	14	1	55930-218	O-RING
7	1	PF53533	LINK	15	1	55930-210	O-RING
8	1	PF53535	VALVE PLATE	16	1	PF55867	HANDLE STOP

PF5-1PK REPAIR PARTS KIT

QTY	PART NO.	PART NAME
1	PF55470	HOSE ASSEMBLY
1	481-008	FILTER ELEMENT
1	55930-025	O-RING
1	55930-329	O-RING
1	PF53602	PUMP GASKET
1	PF53600	SPRING
2	PF53518	PIN
2	355-021	SELF LOCK NUT, 5/16-24
2	372-001	COTTER PIN, 3/32 DIA x 3/4 LG
1	AN5-12A	HHCS, 5/16-24 x 1 11/32 LG
1	55930-218	O-RING
1	55930-210	O-RING
1	PF5-1PKDOC	REPAIR PARTS KIT LIST