

Date: August 23, 2016

MALABAR

INTERNATIONAL

AIRCRAFT MAINTENANCE & SUPPORT EQUIPMENT

OWNER'S MANUAL FOR MALABAR MODEL

PF53481-122P

5 GALLON FLUID DISPENSER

***READ
AND
SAVE***

**THIS
INSTRUCTION
MANUAL**

- * GENERAL DESCRIPTION
- * OPERATION
- * SERVICE
- * PARTS BREAKDOWN

For Service & Spare
Parts, Please Contact:

Malabar International
220 W. Los Angeles Avenue
Simi Valley, California 93065
Phone: (805) 581-0116
Fax: (805) 584-1624
E-mail: sales@malabar.com
Web site: <http://www.malabar.com>

OVER 65 YEARS OF SERVICE & EXPERIENCE

GENERAL DESCRIPTION, OPERATION, SERVICE AND PARTS BREAKDOWN

MALABAR MODEL PF53481-122P 5 GALLON FLUID DISPENSER

CAUTION: AIRCRAFT MANUFACTURER'S SPECIFICATIONS AND INSTRUCTIONS MUST BE FOLLOWED. IN THE EVENT OF CONTRADICTION BETWEEN AIRCRAFT MANUFACTURER'S SPECIFICATIONS AND MALABAR'S, AIRCRAFT MANUFACTURER'S WILL PREVAIL.

SPECIFICATIONS:

| | | |
|----------------------------|------------------|-------------|
| Fluid ----- | MIL-PRF-5606 | |
| Reservoir capacity ----- | 5 U.S. gal | 18.9 liters |
| Pump outlet pressure ----- | 100 psig | 689 kPa |
| Volume per stroke----- | 3.0 cubic in | 49 cc |
| Hose length ----- | 120 in | 3048 mm |
| Net weight (empty)----- | 35 lbs | 15.9 kg |
| Filter rating ----- | 3 micron nominal | |
| Fluid tank color----- | red | |

GENERAL DESCRIPTION:

The Malabar Model PF53481-122P is a 5 gallon fluid dispenser used to service various commercial aircraft. The hand pump dispenser consists of a reservoir, pump assembly, filter assembly, pressure gauge, and a fluid delivery hose with a dust plug assembly.

PREPARATION FOR USE:

The unit is shipped fully assembled. Fill reservoir at fillport with approved fluid. Operate hand pump assembly a few strokes to bleed all air out of the system. The unit is now ready for use.

OPERATION:

1. Remove dust plug and connect the hose to the aircraft service point.
2. Use full steady pumping strokes when operating pump assembly during replenishing.
3. Disconnect the hose from the aircraft service point, replace the dust plug, and store the unit in a dry, dust free location.

ILLUSTRATED PARTS LIST:

Refer to figure 1A, 1B & 1C for unit assembly (see sheets 3, 4 & 5) or figure 2 for pump assembly (see sheet 6).

SERVICING:

1. The frequency of filter change depends on operating conditions. Generally, changes should be made every 3-4 months or sooner if more than normal resistance is felt on the pumping stroke at low pressure. Refer to item 7 in figure 1A (see sheet 3) to change element.

REPAIR AND REPLACEMENT:

No definite time schedule can be established for the overhaul of the pump assembly for the replacement of the various moving parts. The number of times the pump assembly is operated materially affect the life of the working parts. The moving piston seal (item 14) and rod seal (item 15) are normally the first to wear (see sheet 6). This is usually indicated by leakage of fluid past the piston or rod. It is advisable to change piston seal (item 14) and rod seal (item 15) immediately if leakage is discovered. A repair parts kit (P/N PF5-5PK) is available and recommended to keep on hand at your facility. Refer to sheet 7 for the complete list of parts contained in the repair parts kit.

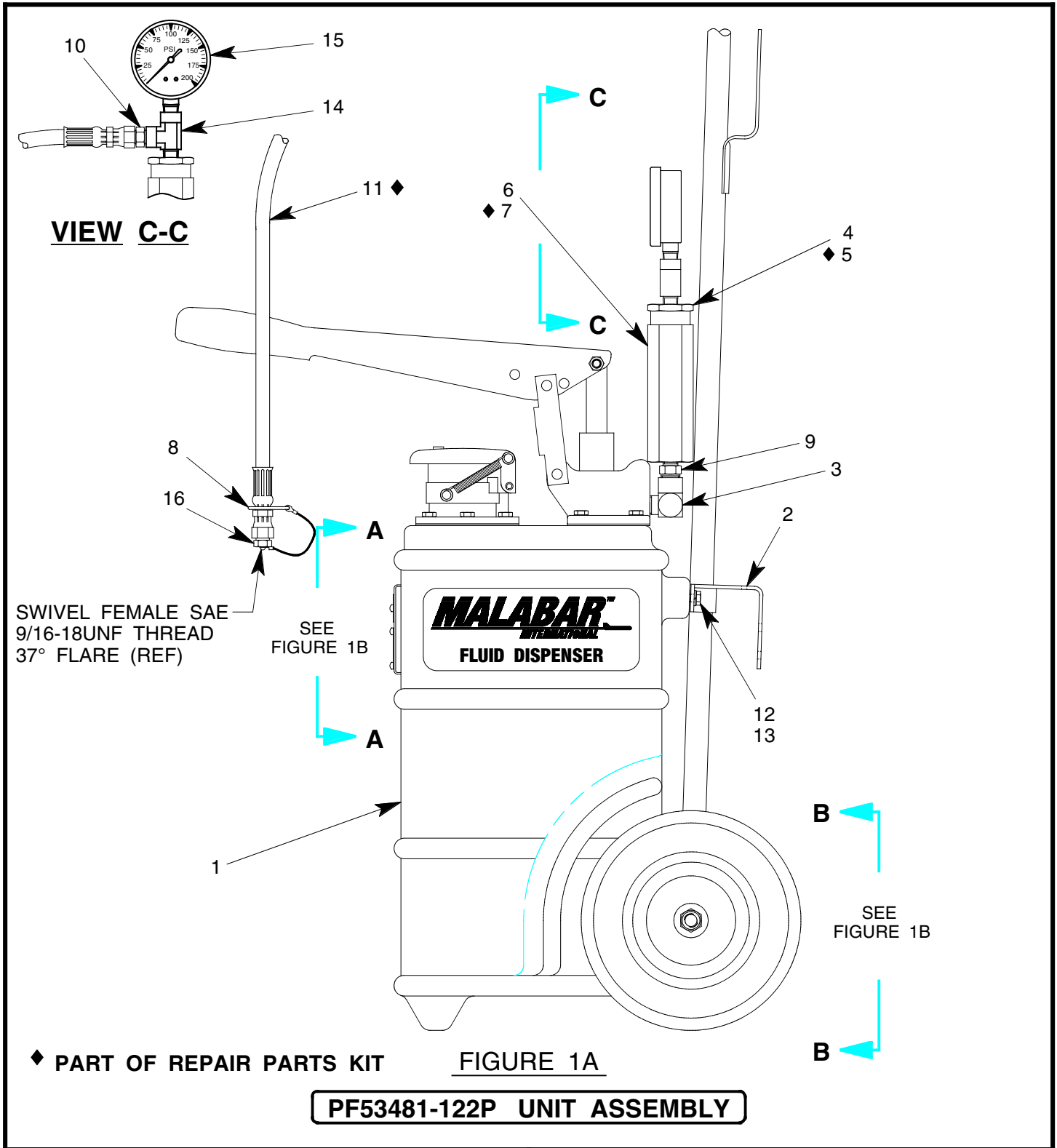

| NO. | QTY | PART NO. | PART NAME | NO. | QTY | PART NO. | PART NAME |
|-----|-----|-----------|-------------------------|-----|-----|-----------|---------------------------|
| 1 | 1 | PF55836-1 | FLUID TANK | 9 | 1 | 711-030 | NIPPLE, 1/4 NPT x 3/8 NPT |
| 2 | 1 | PF55865 | HANDLE SUPPORT WELD | 10 | 1 | 721-004 | CONNECTOR |
| 3 | 1 | 712-017 | ELBOW, STREET, 3/8 NPT | 11 | 1 | PF55456 | HOSE ASSEMBLY |
| 4 | 1 | PF101163 | END CAP, FILTER HOUSING | 12 | 2 | 329-007 | HHCS, 1/4-28 x 21/32 LG |
| 5 | 1 | 55925-025 | O-RING | 13 | 2 | 363-001 | SPLIT LOCKWASHER, 1/4 |
| 6 | 1 | PF101161 | BODY, FILTER HOUSING | 14 | 1 | 713-012 | TEE, 1/4 NPT |
| 7 | 1 | 481-006 | FILTER ELEMENT | 15 | 1 | 482-050 | GAUGE, 0-200 PSIG |
| 8 | 1 | 491-017 | S-HOOK | 16 | 1 | PF55507-6 | DUST PLUG & CABLE ASSY |

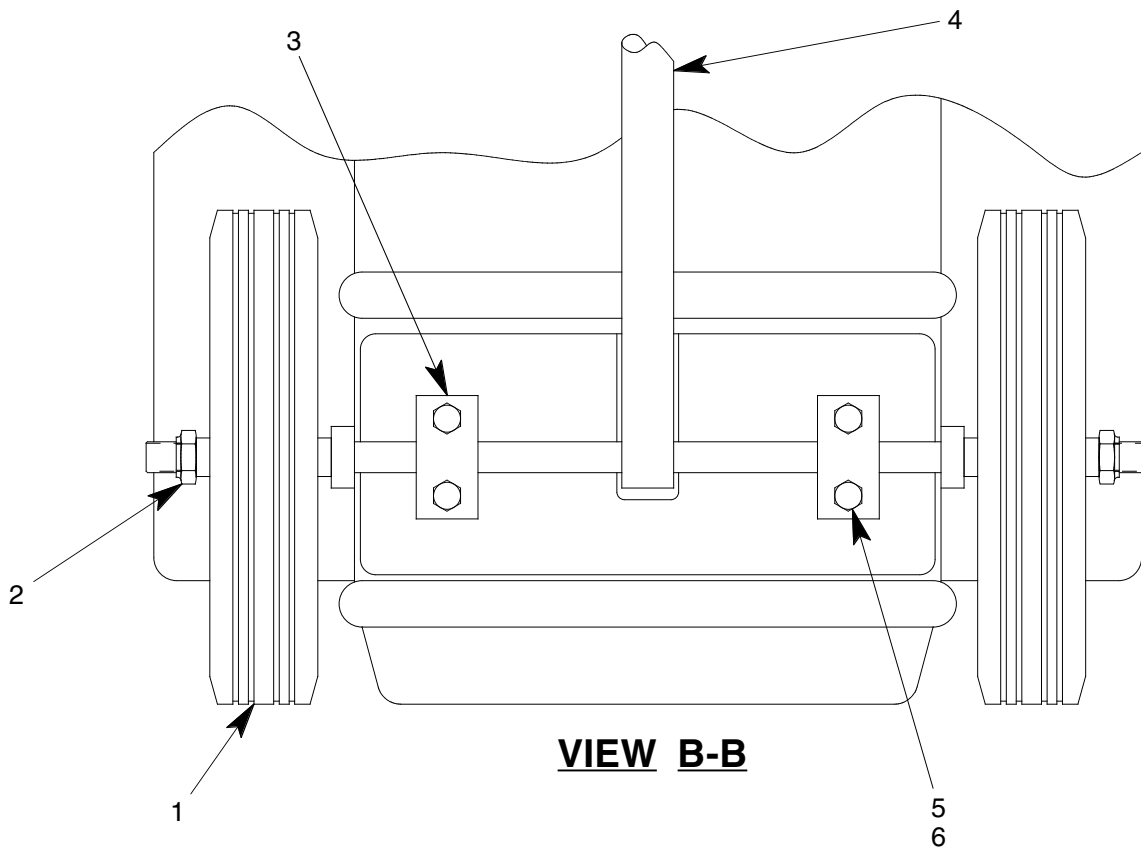
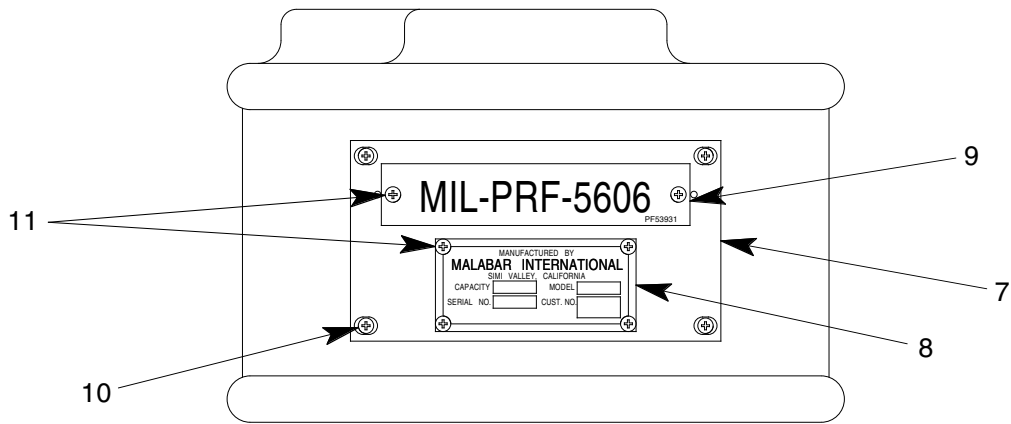
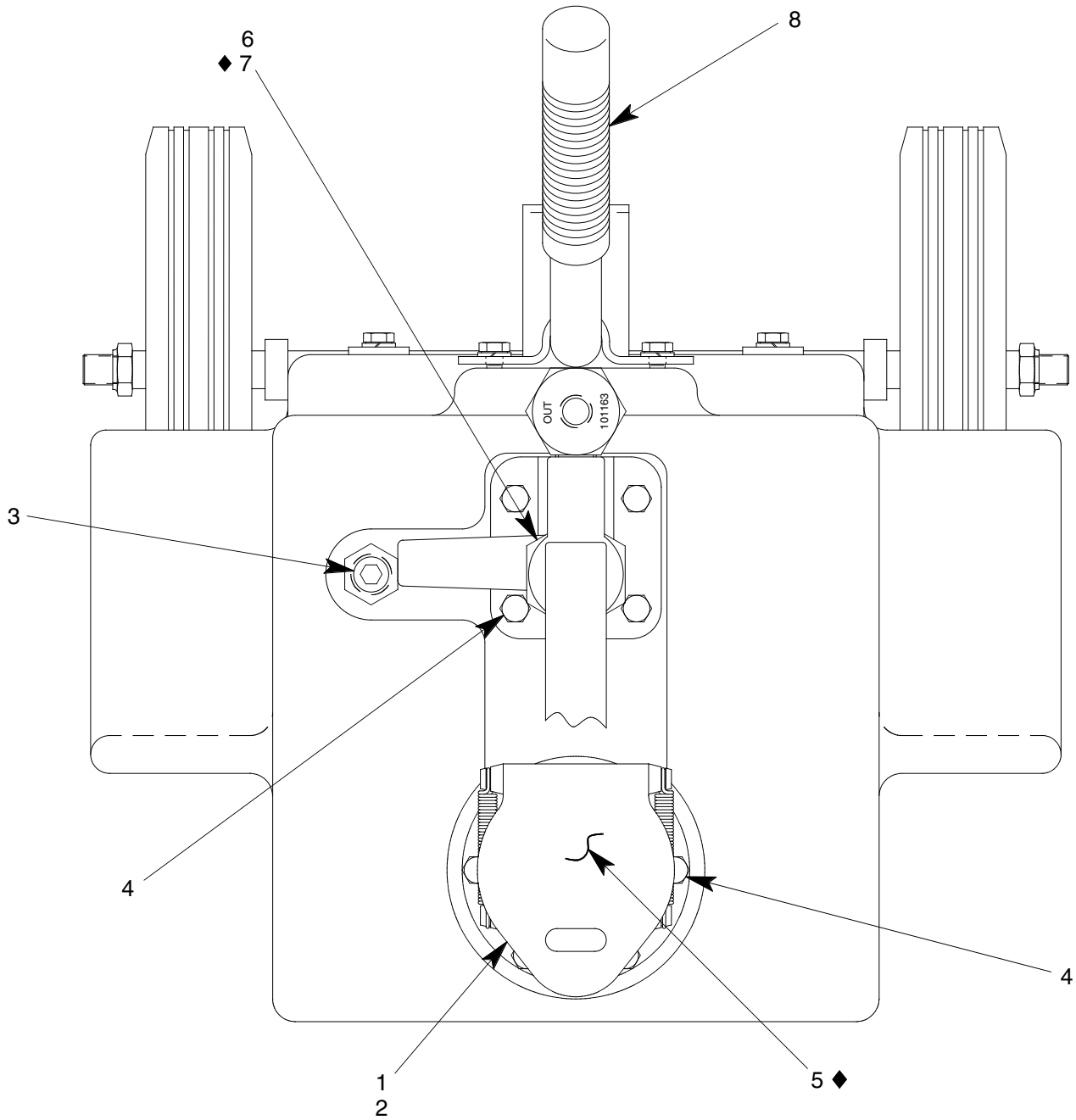

FIGURE 1B

PF53481-122P UNIT ASSEMBLY

| NO. | QTY | PART NO. | PART NAME | NO. | QTY | PART NO. | PART NAME |
|-----|-----|----------|-------------------------|-----|-----|----------|--------------------------|
| 1 | 2 | PF53240 | WHEEL | 7 | 1 | PF55859 | PLACARD PLATE |
| 2 | 2 | 355-013 | LOCKNUT | 8 | 1 | 55997-2 | NAMEPLATE |
| 3 | 2 | PF55858 | SUPPORT STRAP | 9 | 1 | PF53931 | PLACARD, MIL-PRF-5606 |
| 4 | 1 | PF55841 | AXLE-HANDLE WELDMENT | 10 | 4 | 344-011 | FHMS, 6-32 x 7/16 LG |
| 5 | 4 | 329-007 | HHCS, 1/4-28 x 21/32 LG | 11 | 6 | 397-010 | SELF TAPPING SCREW, 6-32 |
| 6 | 4 | 363-001 | SPLIT LOCKWASHER, 1/4 | | | | |



◆ PART OF REPAIR PARTS KIT

FIGURE 1C

PF53481-122P UNIT ASSEMBLY

| NO. | QTY | PART NO. | PART NAME | NO. | QTY | PART NO. | PART NAME |
|-----|-----|----------|-------------------------|-----|-----|-----------|---------------|
| 1 | 1 | PF53549 | FILLPORT ASSY | 5 | 1 | 55925-329 | O-RING |
| 2 | 1 | PF53628 | GASKET, FILLPORT | 6 | 1 | PF55480-2 | PUMP ASSEMBLY |
| 3 | 1 | 717-007 | PLUG, 3/8 NPT | 7 | 1 | PF53602 | GASKET |
| 4 | 10 | 329-007 | HHCS, 1/4-28 x 21/32 LG | 8 | 1 | 494-006 | HANDLE GRIP |

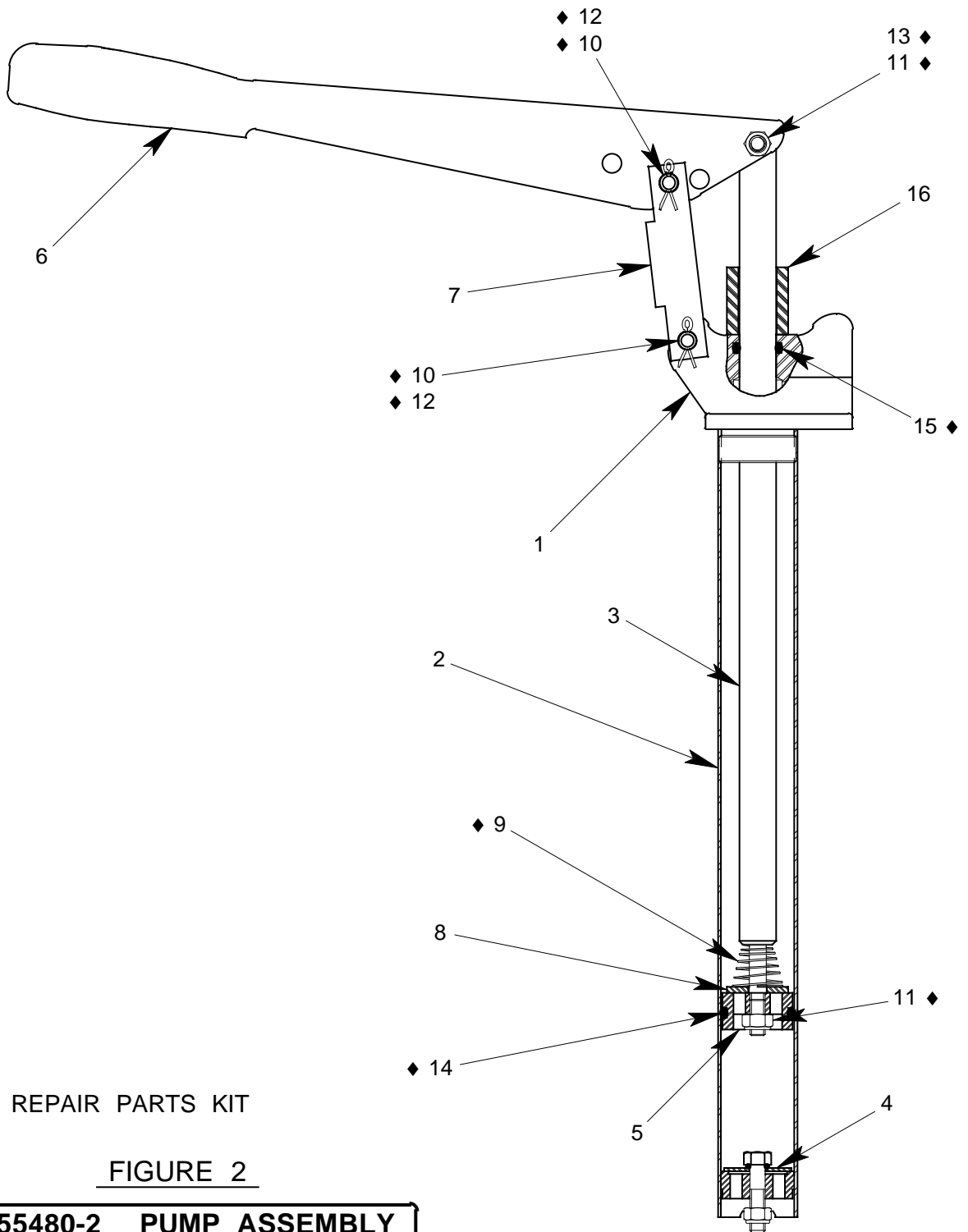

◆ PART OF REPAIR PARTS KIT

FIGURE 2

PF55480-2 PUMP ASSEMBLY

| NO. | QTY | PART NO. | PART NAME | NO. | QTY | PART NO. | PART NAME |
|-----|-----|----------|----------------|-----|-----|-----------|---------------------------|
| 1 | 1 | PF55466 | PUMP BODY | 9 | 1 | PF53600 | SPRING |
| 2 | 1 | PF53514 | TUBE | 10 | 2 | PF53518 | PIN |
| 3 | 1 | PF53515 | PLUNGER ROD | 11 | 2 | 355-021 | SELF LOCK NUT, 5/16-24 |
| 4 | 1 | PF53594 | VALVE ASSEMBLY | 12 | 2 | 372-001 | COTTER PIN, 3/32 x 3/4 LG |
| 5 | 1 | PF53599 | PLUNGER BODY | 13 | 1 | AN5-12A | HHCS, 5/16-24 x 1 11/32 |
| 6 | 1 | PF53517 | HANDLE | 14 | 1 | 55925-218 | O-RING |
| 7 | 1 | PF53533 | LINK | 15 | 1 | 55925-210 | O-RING |
| 8 | 1 | PF53535 | VALVE PLATE | 16 | 1 | PF55867 | HANDLE STOP |

PF5-5PK REPAIR PARTS KIT

| QTY | PART NO. | PART NAME |
|-----|------------|-------------------------------|
| 1 | PF55456 | HOSE ASSEMBLY |
| 1 | 481-006 | FILTER ELEMENT |
| 1 | 55925-025 | O-RING |
| 1 | 55925-329 | O-RING |
| 1 | PF53602 | PUMP GASKET |
| 1 | PF53600 | SPRING |
| 2 | PF53518 | PIN |
| 2 | 355-021 | SELF LOCK NUT, 5/16-24 |
| 2 | 372-001 | COTTER PIN, 3/32 DIA x 3/4 LG |
| 1 | AN5-12A | HHCS, 5/16-24 x 1 11/32 LG |
| 1 | 55925-218 | O-RING |
| 1 | 55925-210 | O-RING |
| 1 | PF5-5PKDOC | REPAIR PARTS KIT LIST |