

MALABAR

INTERNATIONAL

AIRCRAFT MAINTENANCE & SUPPORT EQUIPMENT

OWNER'S MANUAL FOR MALABAR MODEL

PF53481-53PWS

5 GALLON FLUID DISPENSER

***READ
AND
SAVE***

**THIS
INSTRUCTION
MANUAL**

- * GENERAL DESCRIPTION
- * OPERATION
- * SERVICE
- * PARTS BREAKDOWN

For Service & Spare
Parts, Please Contact:

Malabar International
220 W. Los Angeles Avenue
Simi Valley, California 93065
Phone: (805) 581-0116
Fax: (805) 584-1624
E-mail: sales@malabar.com
Web site: <http://www.malabar.com>

OVER 65 YEARS OF SERVICE & EXPERIENCE

GENERAL DESCRIPTION, OPERATION, SERVICE AND PARTS BREAKDOWN

***MALABAR MODEL PF53481-53PWS
5 GALLON FLUID DISPENSER***

CAUTION: AIRCRAFT MANUFACTURER'S SPECIFICATIONS AND INSTRUCTIONS MUST BE FOLLOWED. IN THE EVENT OF CONTRADICTION BETWEEN AIRCRAFT MANUFACTURER'S SPECIFICATIONS AND MALABAR'S, AIRCRAFT MANUFACTURER'S WILL PREVAIL.

SPECIFICATIONS:

Fluid -----	MIL-PRF-7808	
Reservoir capacity-----	5 U.S. gal	18.9 liters
Pump outlet pressure -----	100 psig	689 kPa
Volume per stroke -----	3.0 cubic in	49 cc
Relief valve setting -----	125 ± 10 psig	862 ± 69 kPa
Hose length -----	120 in	3048 mm
Net weight (empty) -----	35 lbs	15.9 kg
Filter rating-----	1 micron nominal	
Fluid tank color -----	green	

GENERAL DESCRIPTION:

The Malabar Model PF53481-53PWS is a 5 gallon fluid dispenser used to service various commercial aircraft. The hand pump dispenser consists of a reservoir, pump assembly, water stop filter assembly, and a fluid delivery hose with a coupling.

PREPARATION FOR USE:

The unit is shipped fully assembled. Fill reservoir at fillport with approved fluid. Operate hand pump assembly a few strokes to bleed all air out of the system. The unit is now ready for use.

OPERATION:

1. Remove dust plug from hose end coupling and connect the hose coupling to the aircraft service point.
2. Use full steady pumping strokes when operating pump assembly during replenishing.
3. Disconnect the hose coupling from the aircraft service point, replace the dust plug and store the unit in a dry, dust free location.

ILLUSTRATED PARTS LIST:

Refer to figure 1A, 1B & 1C for unit assembly (see sheets 3, 4 & 5) or figure 2 for pump assembly (see sheet 6).

SERVICING:

1. The frequency of filter change depends on operating conditions. Generally, changes should be made every 3-4 months or sooner if more than normal resistance is felt on the pumping stroke at low pressure. Refer to item 10 in figure 3 (see sheet 7) to change element. Proper element must be installed, otherwise unit will not pump fluid.
2. NOTE: The relief valve should not be removed. The relief is set to by-pass oil back to the reservoir at 125 ± 10 PSIG.

REPAIR AND REPLACEMENT:

No definite time schedule can be established for the overhaul of the pump assembly for the replacement of the various moving parts. The number of times the pump assembly is operated materially affect the life of the working parts. The moving piston seal (item 14) and rod seal (item 15) are normally the first to wear (see sheet 6). This is usually indicated by leakage of fluid past the piston or rod. It is advisable to change piston seal (item 14) and rod seal (item 15) immediately if leakage is discovered. A repair parts kit (P/N PF5-6PK) is available and recommended to keep on hand at your facility. Refer to sheet 8 for the complete list of parts contained in the repair parts kit.

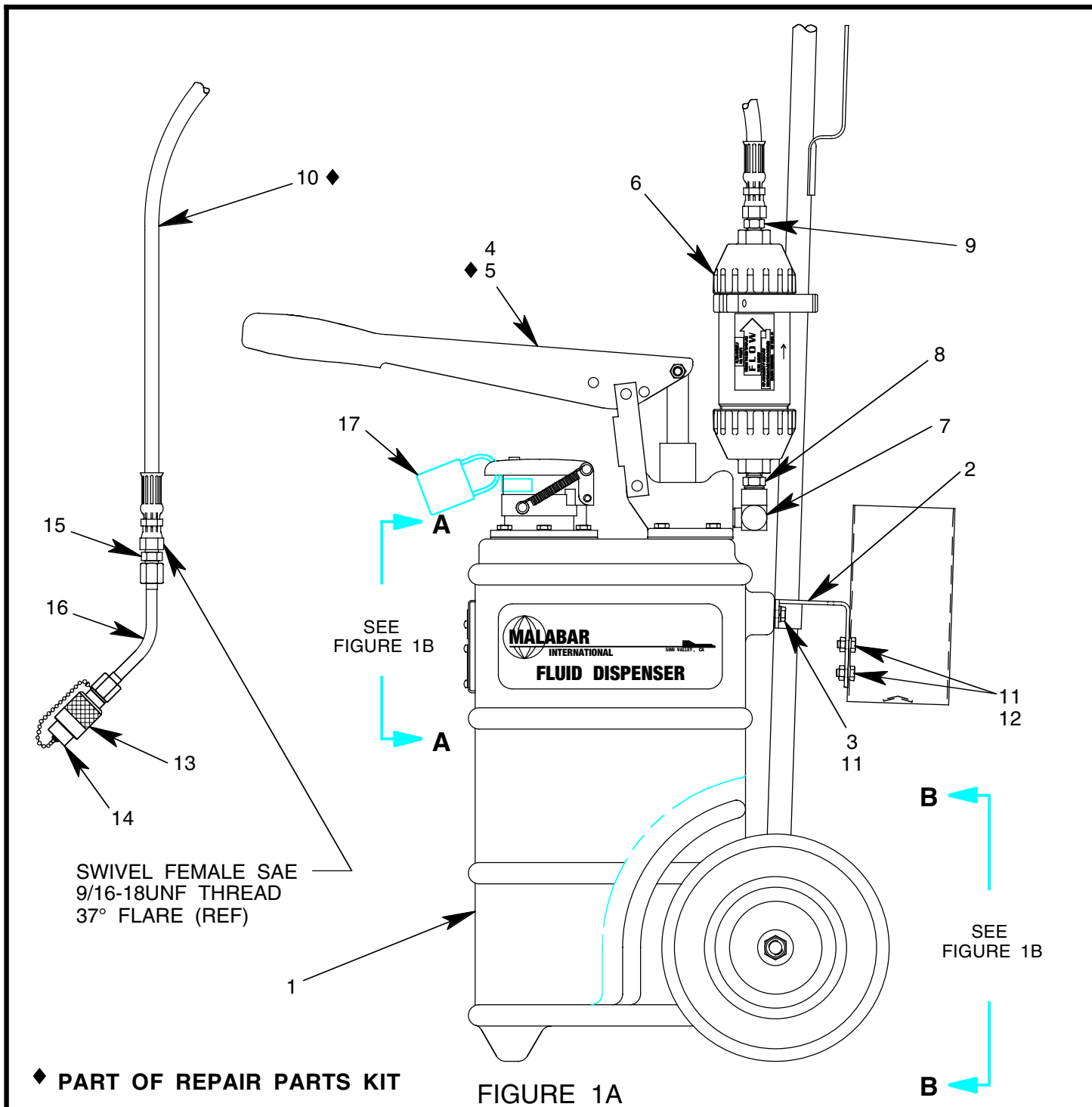

PF53481-53PWS UNIT ASSEMBLY

NO.	QTY	PART NO.	PART NAME	NO.	QTY	PART NO.	PART NAME
1	1	PF55836-3	FLUID TANK	10	1	PF55456	HOSE ASSEMBLY
2	1	PF55865	HANDLE SUPPORT WELD	11	4	329-007	HHCS, 1/4-28 x 21/32 LG
3	2	363-001	SPLIT LOCKWASHER, 1/4	12	2	355-007	NUT, SELF LOCKING, 1/4-28
4	1	PF55847-2	PUMP ASSEMBLY	13	1	736-013	COUPLING
5	1	PF53602	GASKET, PUMP	14	1	PF55987	DUST PLUG AND CHAIN
6	1	PF55873	FILTER ASSEMBLY	15	1	721-006	CONNECTOR
7	1	712-017	ELBOW, STREET, 3/8 NPT	16	1	PF55817	ELBOW ASSEMBLY
8	1	711-030	NIPPLE, 1/4 NPT x 3/8 NPT	17	REF	—	LOCK SUPPLIED BY OTHERS
9	1	721-004	CONNECTOR				

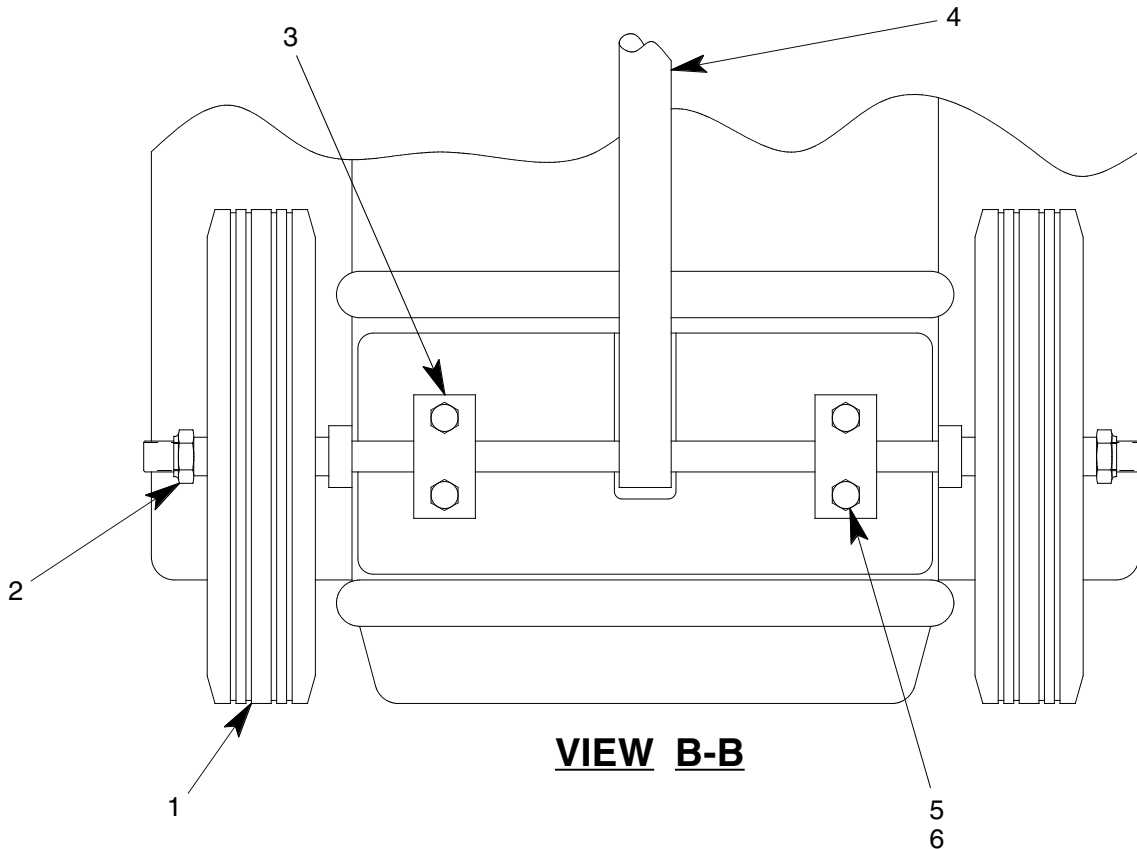
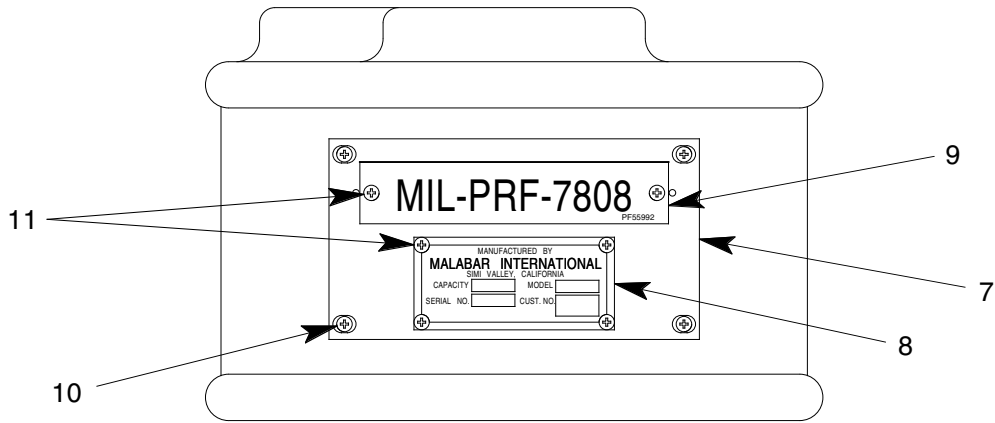
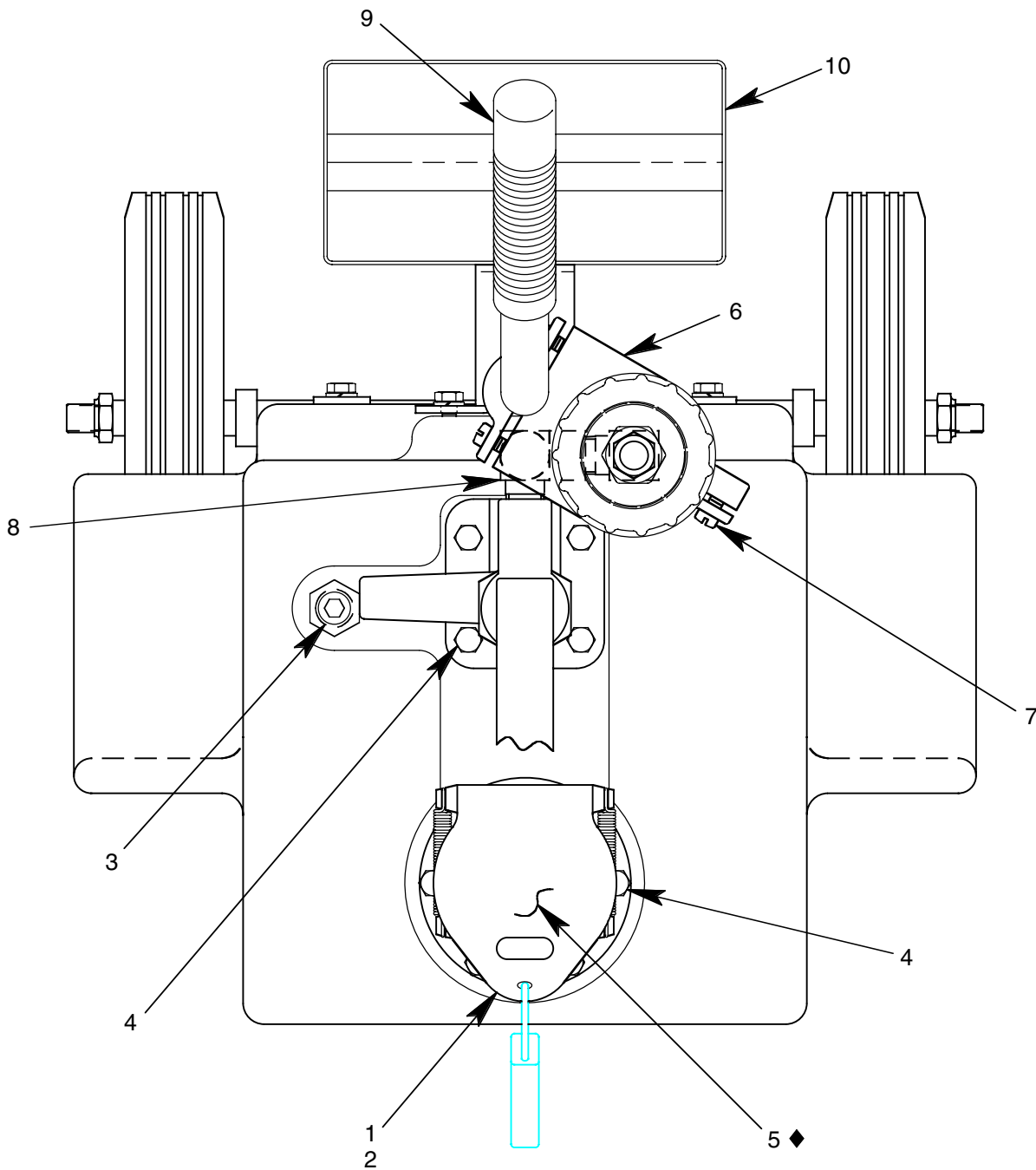

FIGURE 1B

PF53481-53PWS UNIT ASSEMBLY

NO.	QTY	PART NO.	PART NAME	NO.	QTY	PART NO.	PART NAME
1	2	PF53240	WHEEL	7	1	PF55859	PLACARD PLATE
2	2	355-013	LOCKNUT	8	1	55997-2	NAMEPLATE
3	2	PF55858	SUPPORT STRAP	9	1	PF55992	PLACARD, MIL-PRF-7808
4	1	PF55841	AXLE-HANDLE WELDMENT	10	4	344-011	FHMS, 6-32 x 7/16 LG
5	4	329-007	HHCS, 1/4-28 x 21/32 LG	11	6	397-010	SELF TAPPING SCREW, 6-32
6	4	363-001	SPLIT LOCKWASHER, 1/4				



◆ PART OF REPAIR PARTS KIT

FIGURE 1C

PF53481-53PWS UNIT ASSEMBLY

NO.	QTY	PART NO.	PART NAME	NO.	QTY	PART NO.	PART NAME
1	1	PF53549	FILLPORT ASSEMBLY	6	1	PF55871-2	YOKE CLAMP
2	1	PF53628	GASKET, FILLPORT	7	3	342-010	SCREW, FIL HD, 1/4-20 x 1" LG
3	1	717-007	PLUG, 3/8 NPT	8	1	712-017	ELBOW, STREET, 3/8 NPT
4	10	329-007	HHCS, 1/4-28 x 21/32 LG	9	1	494-006	HANDLE GRIP
5	1	55925-329	O-RING	10	1	PF53842	BOX

◆ PART OF REPAIR PARTS KIT

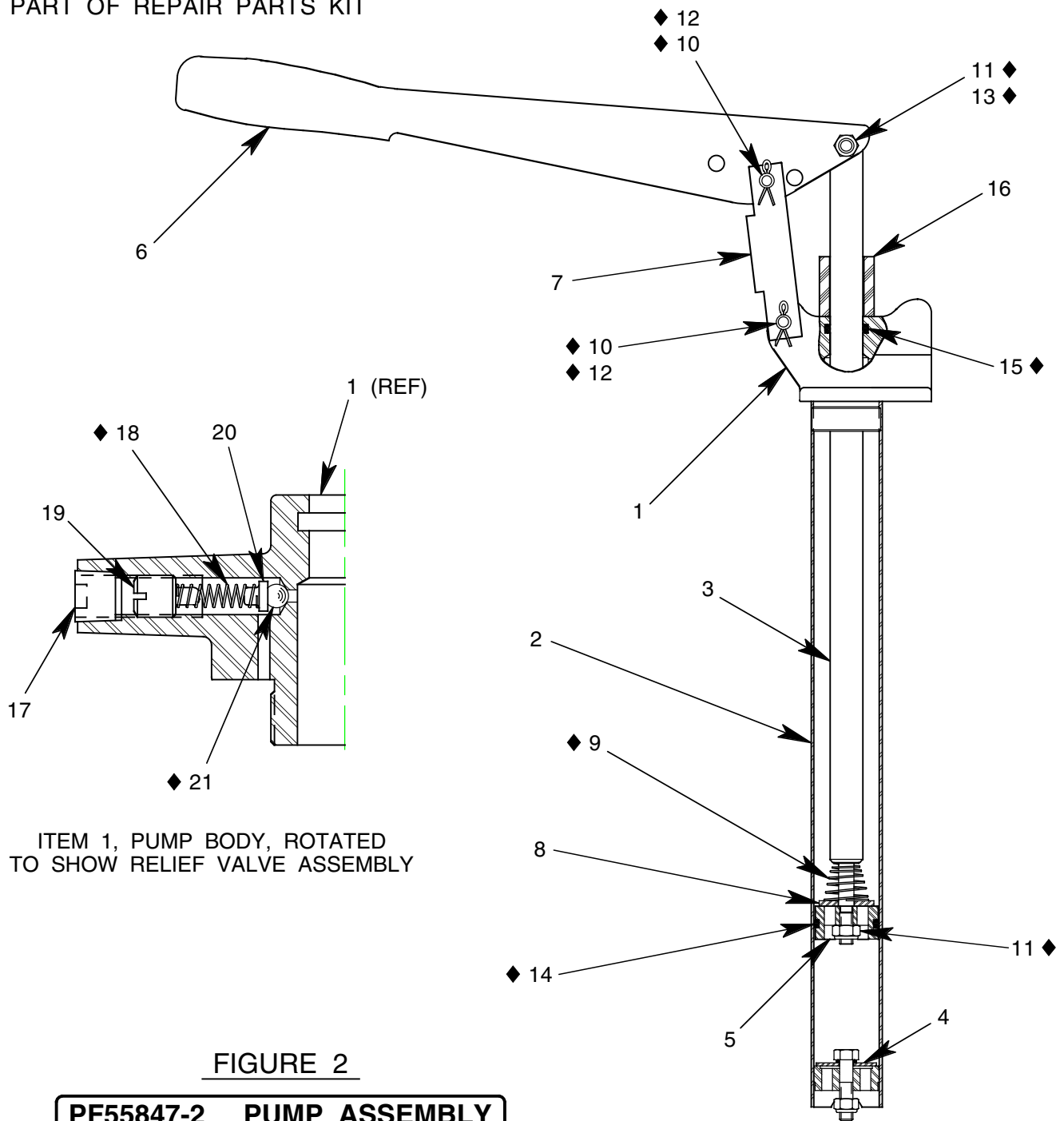

NO.	QTY	PART NO.	PART NAME	NO.	QTY	PART NO.	PART NAME
1	1	PF55846	PUMP BODY	12	2	372-001	COTTER PIN, 3/32 x 3/4 LG
2	1	PF53514	TUBE	13	1	AN5-12A	HHCS, 5/16-24 x 1 11/32 LG
3	1	PF53515	PLUNGER ROD	14	1	55925-218	O-RING
4	1	PF53594	VALVE ASSEMBLY	15	1	55925-210	O-RING
5	1	PF53599	PLUNGER BODY	16	1	PF55867	HANDLE STOP
6	1	PF53517	HANDLE	17	1	717-006	PLUG, 1/4 NPT
7	1	PF53533	LINK	18	1	495-038	SPRING
8	1	PF53535	VALVE PLATE	19	1	55148	SET SCREW
9	1	PF53600	SPRING	20	1	55153	SPRING GUIDE
10	2	PF53518	PIN	21	1	412-004	STEEL BALL, 1/4 DIA
11	2	355-021	SELF LOCK NUT, 5/16-24				

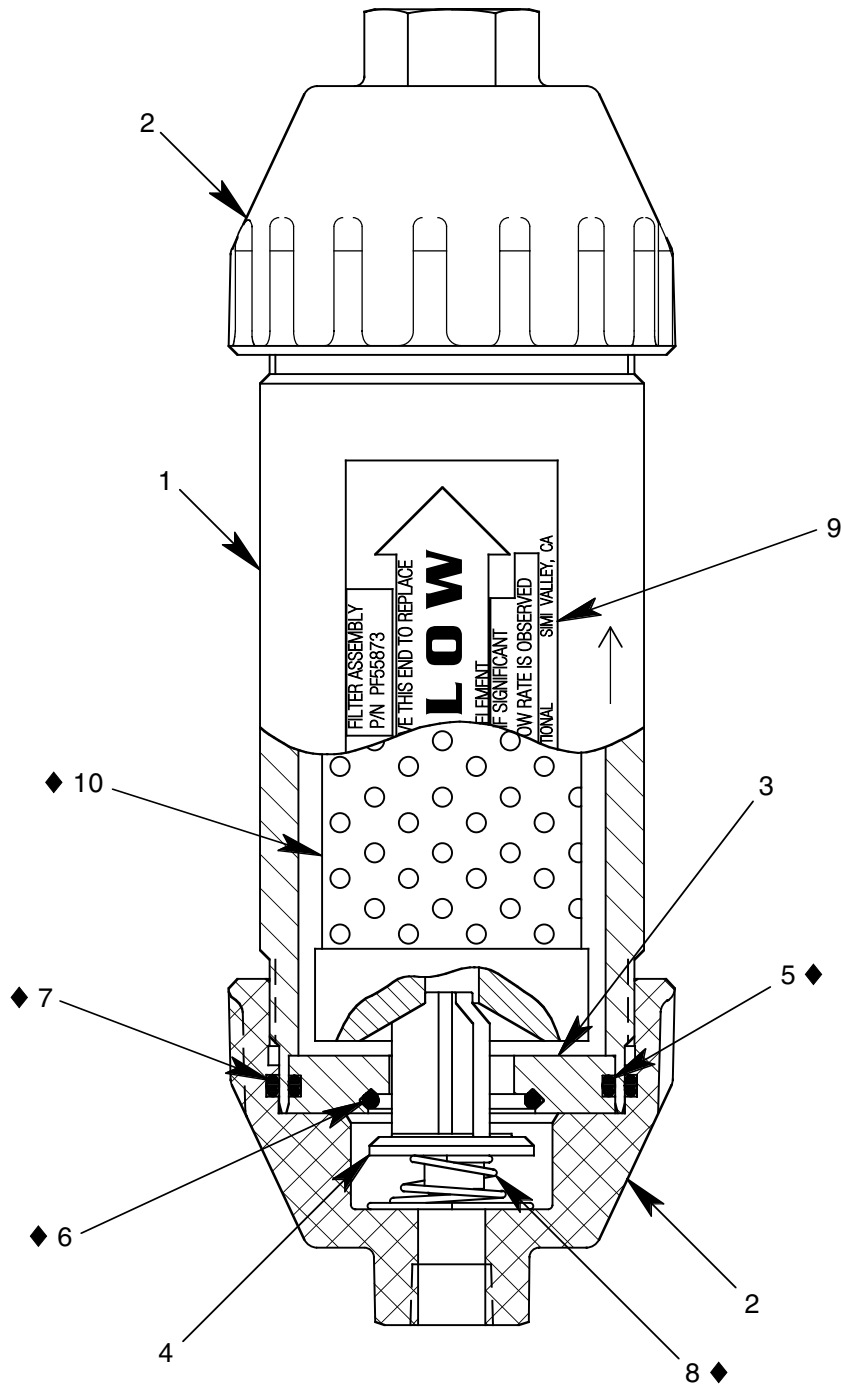

◆ PART OF REPAIR PARTS KIT

FIGURE 3

PF55873 FILTER ASSEMBLY

NO.	QTY	PART NO.	PART NAME	NO.	QTY	PART NO.	PART NAME
1	1	PF55849	FILTER HOUSING	6	1	55925-120	O-RING
2	2	PF55852	FILTER HOUSING END CAP	7	2	55925-140	O-RING
3	1	PF55853	RETAINER DISC	8	1	495-039	SPRING
4	1	PF55850	RETAINER VALVE	9	1	PF55872	DECAL, FLOW
5	1	55925-135	O-RING	10	1	481-068	FILTER ELEMENT

PF5-6PK REPAIR PARTS KIT

QTY	PART NO.	PART NAME
1	PF55456	HOSE ASSEMBLY
1	55925-329	O-RING
1	PF53602	PUMP GASKET
1	PF53600	SPRING
2	PF53518	PIN
2	355-021	SELF LOCK NUT, 5/16-24
2	372-001	COTTER PIN, 3/32 DIA x 3/4 LG
1	AN5-12A	HHCS, 5/16-24 x 1 11/32 LG
1	55925-218	O-RING
1	55925-210	O-RING
1	495-038	SPRING
1	412-004	STEEL BALL, 1/4 DIA
1	55925-135	O-RING
1	55925-120	O-RING
2	55925-140	O-RING
1	495-039	SPRING
1	481-068	FILTER ELEMENT
1	PF5-6PKDOC	REPAIR PARTS KIT LIST