

MALABAR

INTERNATIONAL

AIRCRAFT MAINTENANCE & SUPPORT EQUIPMENT

OWNER'S MANUAL FOR MALABAR MODEL

PF53481-57P

5 GALLON FLUID DISPENSER

***READ
AND
SAVE***

**THIS
INSTRUCTION
MANUAL**

- * GENERAL DESCRIPTION
- * OPERATION
- * SERVICE
- * PARTS BREAKDOWN

For Service & Spare
Parts, Please Contact:

Malabar International
220 W. Los Angeles Avenue
Simi Valley, California 93065
Phone: (805) 581-0116
Fax: (805) 584-1624
E-mail: sales@malabar.com
Web site: <http://www.malabar.com>

OVER 65 YEARS OF SERVICE & EXPERIENCE

GENERAL DESCRIPTION, OPERATION, SERVICE AND PARTS BREAKDOWN

***MALABAR MODEL PF53481-57P
5 GALLON FLUID DISPENSER***

CAUTION: AIRCRAFT MANUFACTURER'S SPECIFICATIONS AND INSTRUCTIONS MUST BE FOLLOWED. IN THE EVENT OF CONTRADICTION BETWEEN AIRCRAFT MANUFACTURER'S SPECIFICATIONS AND MALABAR'S, AIRCRAFT MANUFACTURER'S WILL PREVAIL.

SPECIFICATIONS:

Fluid -----	GEAR STRUT	
Reservoir capacity -----	5 U.S. gal	18.9 liters
Pump outlet pressure -----	100 psig	689 kPa
Volume per stroke-----	3.0 cubic in	49 cc
Hose length-----	120 in	3048 mm
Net weight (empty)-----	35 lbs	15.9 kg
Filter rating-----	3 micron nominal	
Fluid tank color-----	red	

GENERAL DESCRIPTION:

The Malabar Model PF53481-57P is a 5 gallon fluid dispenser used to service various commercial aircraft. The hand pump dispenser consists of a reservoir, pump assembly, filter assembly, fluid meter, pressure gauge, lockable fillport and a fluid delivery hose.

PREPARATION FOR USE:

The unit is shipped fully assembled. Fill reservoir at fillport with approved fluid. Operate hand pump assembly a few strokes to bleed all air out of the system. The unit is now ready for use.

OPERATION:

1. Connect the hose to the aircraft service point.
2. Use full steady pumping strokes when operating pump assembly during replenishing.
3. Disconnect the hose from the aircraft service point and store the unit in a dry, dust free location.

ILLUSTRATED PARTS LIST:

Refer to figure 1A, 1B & 1C for unit assembly (see sheets 3, 4 & 5) or figure 2 for pump assembly (see sheet 6).

SERVICING:

1. The frequency of filter change depends on operating conditions. Generally, changes should be made every 3-4 months or sooner if more than normal resistance is felt on the pumping stroke at low pressure. Refer to item 7 in figure 1A (see sheet 3) to change element.

REPAIR AND REPLACEMENT:

No definite time schedule can be established for the overhaul of the pump assembly for the replacement of the various moving parts. The number of times the pump assembly is operated materially affect the life of the working parts. The moving piston seal (item 14) and rod seal (item 15) are normally the first to wear (see sheet 6). This is usually indicated by leakage of fluid past the piston or rod. It is advisable to change piston seal (item 14) and rod seal (item 15) immediately if leakage is discovered. A repair parts kit (P/N PF5-5PK) is available and recommended to keep on hand at your facility. Refer to sheet 7 for the complete list of parts contained in the repair parts kit.

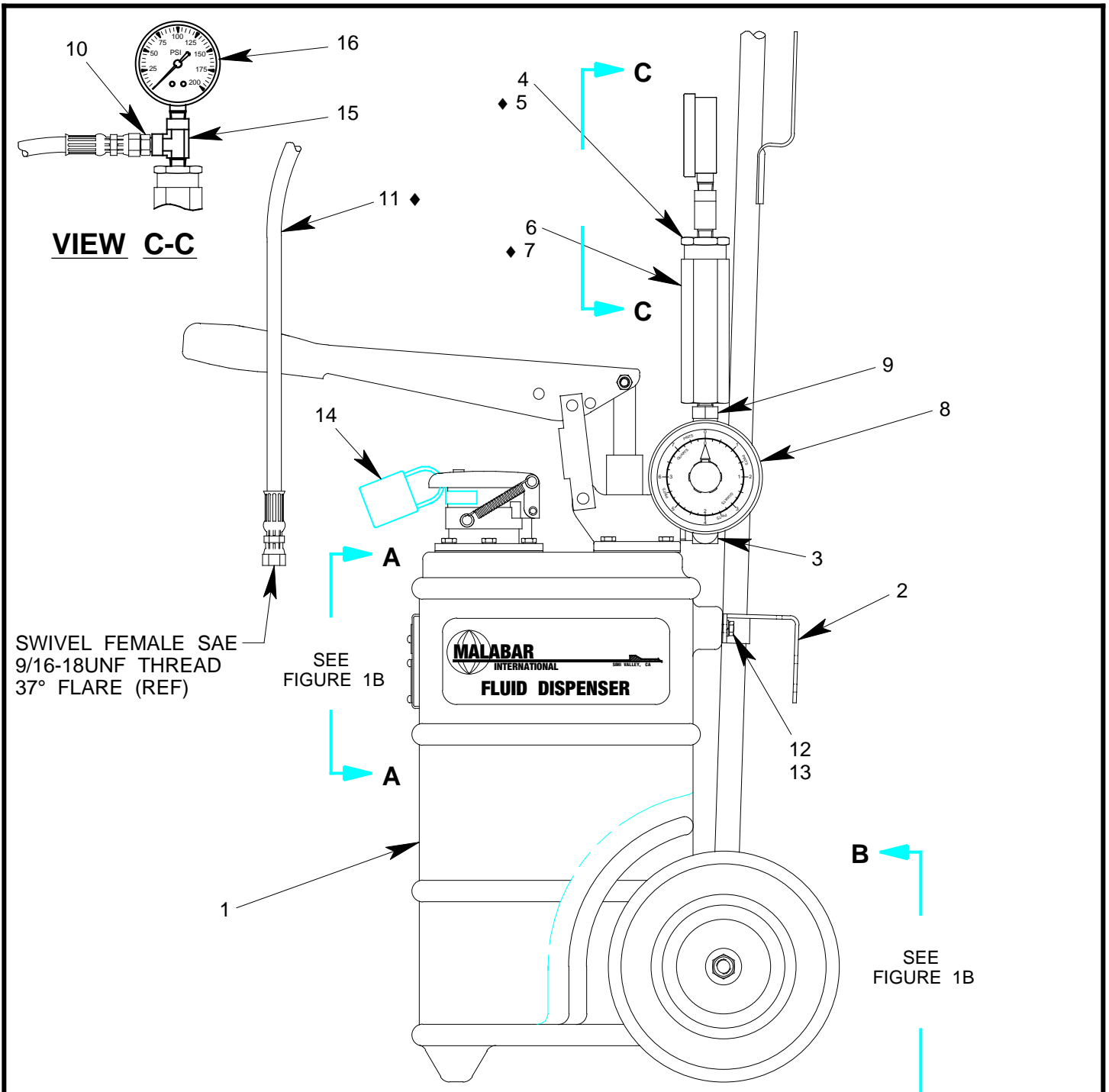

◆ PART OF REPAIR PARTS KIT

FIGURE 1A

PF53481-57P UNIT ASSEMBLY

NO.	QTY	PART NO.	PART NAME	NO.	QTY	PART NO.	PART NAME
1	1	PF55836-1	FLUID TANK	9	1	711-079	NIPPLE, 1/4 NPT x 1/2 NPT
2	1	PF55865	HANDLE SUPPORT WELD	10	1	721-004	CONNECTOR
3	1	712-017	ELBOW, STREET, 3/8 NPT	11	1	PF55456	HOSE ASSEMBLY
4	1	PF101163	END CAP, FILTER HOUSING	12	2	329-007	HHCS, 1/4-28 x 21/32 LG
5	1	55925-025	O-RING	13	2	363-001	SPLIT LOCKWASHER, 1/4
6	1	PF101161	BODY, FILTER HOUSING	14	REF	—	LOCK SUPPLIED BY OTHERS
7	1	481-006	FILTER ELEMENT	15	1	713-012	TEE, 1/4 NPT
8	1	486-024	FLUID METER	16	1	482-050	GAUGE, 0-200 PSIG

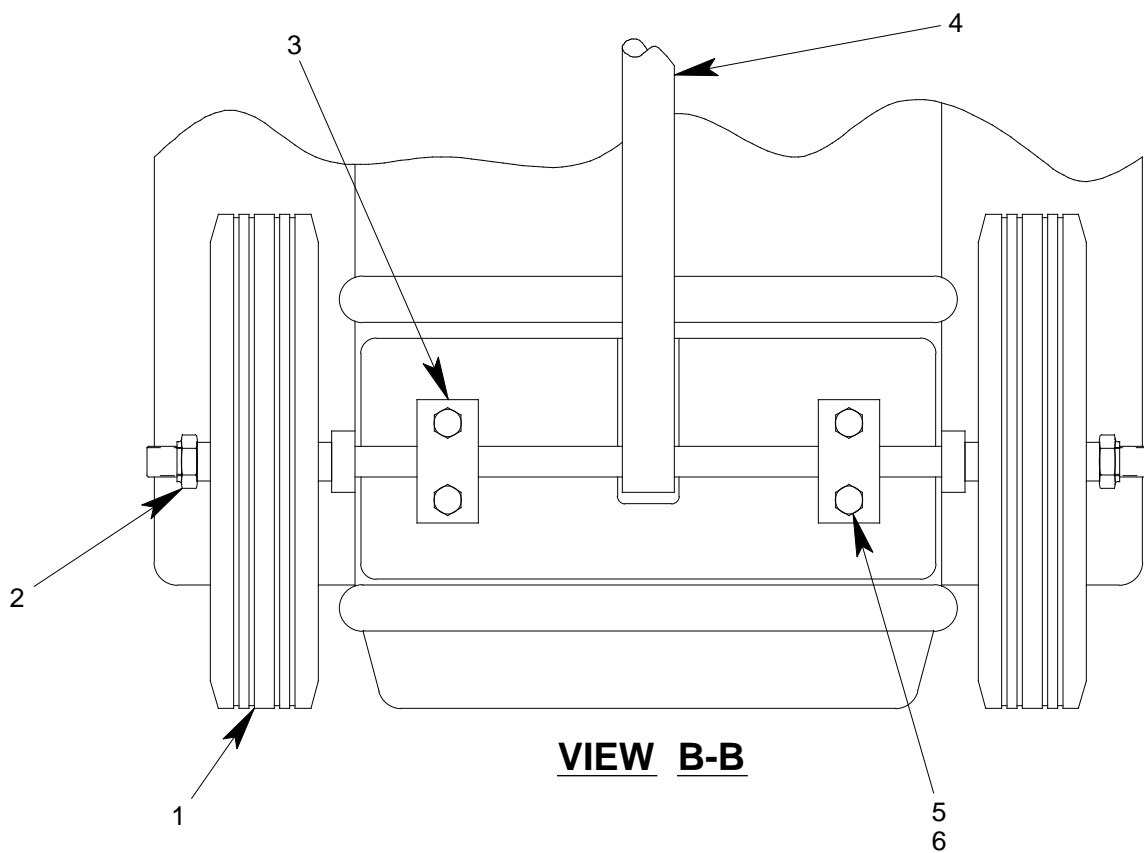
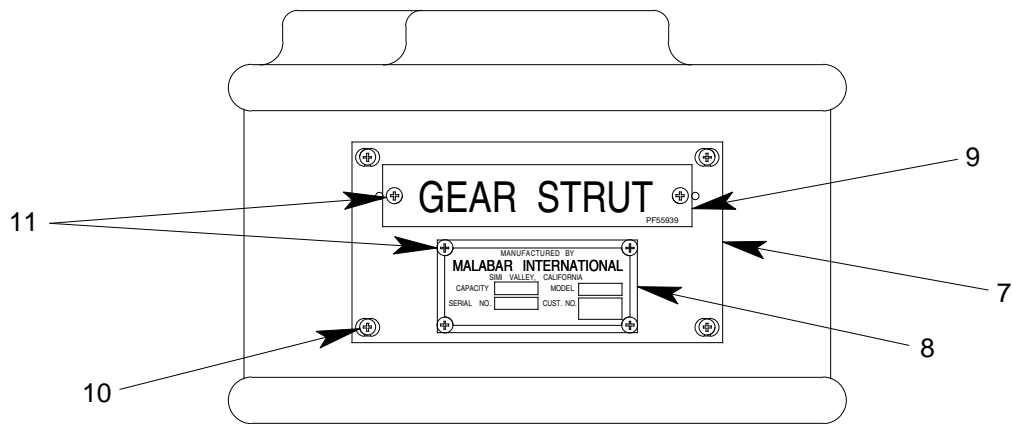
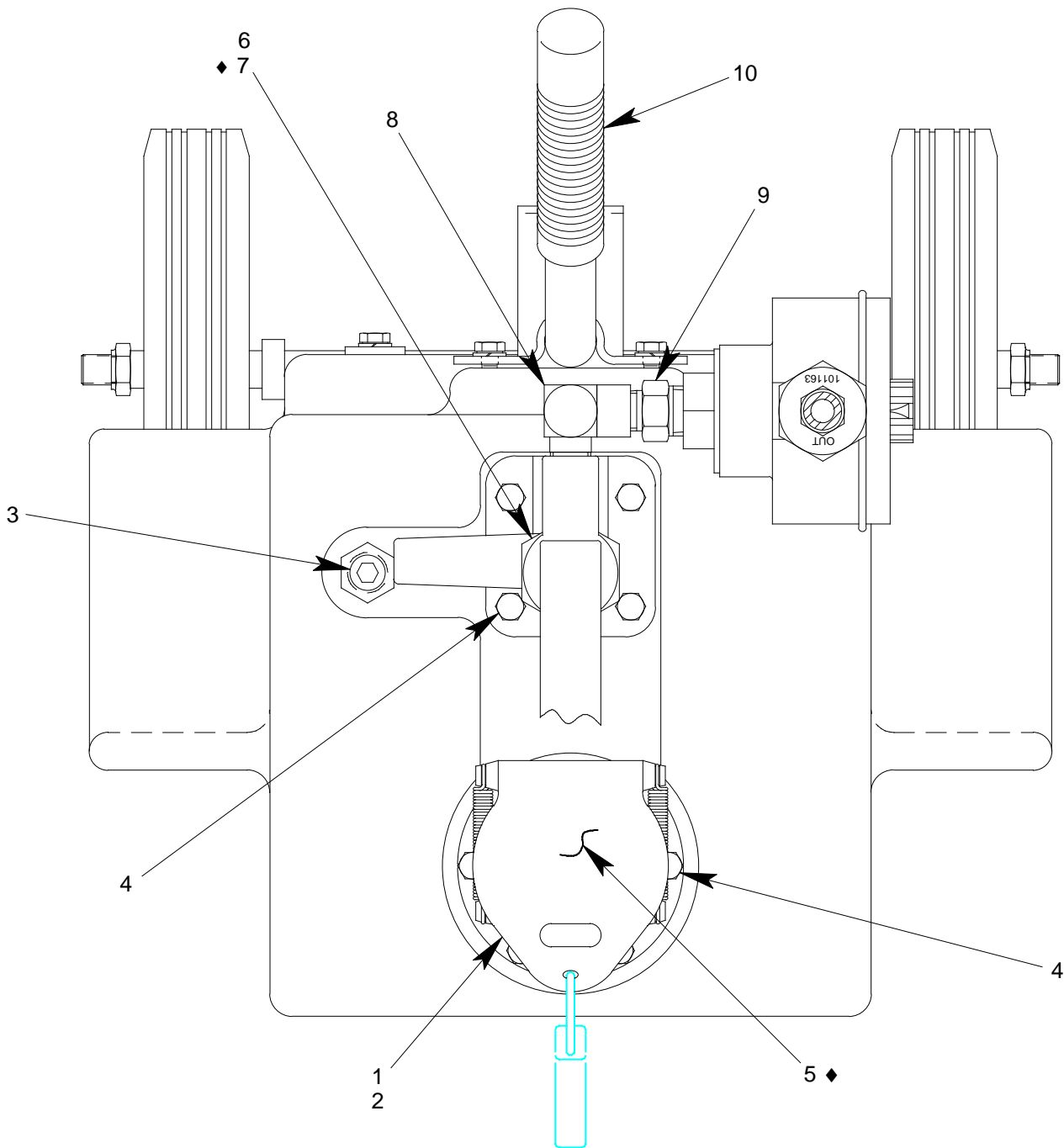

FIGURE 1B

PF53481-57P UNIT ASSEMBLY

NO.	QTY	PART NO.	PART NAME	NO.	QTY	PART NO.	PART NAME
1	2	PF53240	WHEEL	7	1	PF55859	PLACARD PLATE
2	2	355-013	LOCKNUT	8	1	55997-2	NAMEPLATE
3	2	PF55858	SUPPORT STRAP	9	1	PF55939	PLACARD, GEAR STRUT
4	1	PF55841	AXLE-HANDLE WELDMENT	10	4	344-011	FHMS, 6-32 x 7/16 LG
5	4	329-007	HHCS, 1/4-28 x 21/32 LG	11	6	397-010	SELF TAPPING SCREW, 6-32
6	4	363-001	SPLIT LOCKWASHER, 1/4				



◆ PART OF REPAIR PARTS KIT

FIGURE 1C

PF53481-57P UNIT ASSEMBLY

NO.	QTY	PART NO.	PART NAME	NO.	QTY	PART NO.	PART NAME
1	1	PF55956	LOCKING FILLPORT ASSY	6	1	PF55480-2	PUMP ASSEMBLY
2	1	PF53628	GASKET, FILLPORT	7	1	PF53602	GASKET
3	1	717-007	PLUG, 3/8 NPT	8	1	712-017	ELBOW, STREET, 3/8 NPT
4	10	329-007	HHCS, 1/4-28 x 21/32 LG	9	1	711-022	NIPPLE, 3/8 NPT x 1/2 NPT
5	1	55925-329	O-RING	10	1	494-006	HANDLE GRIP

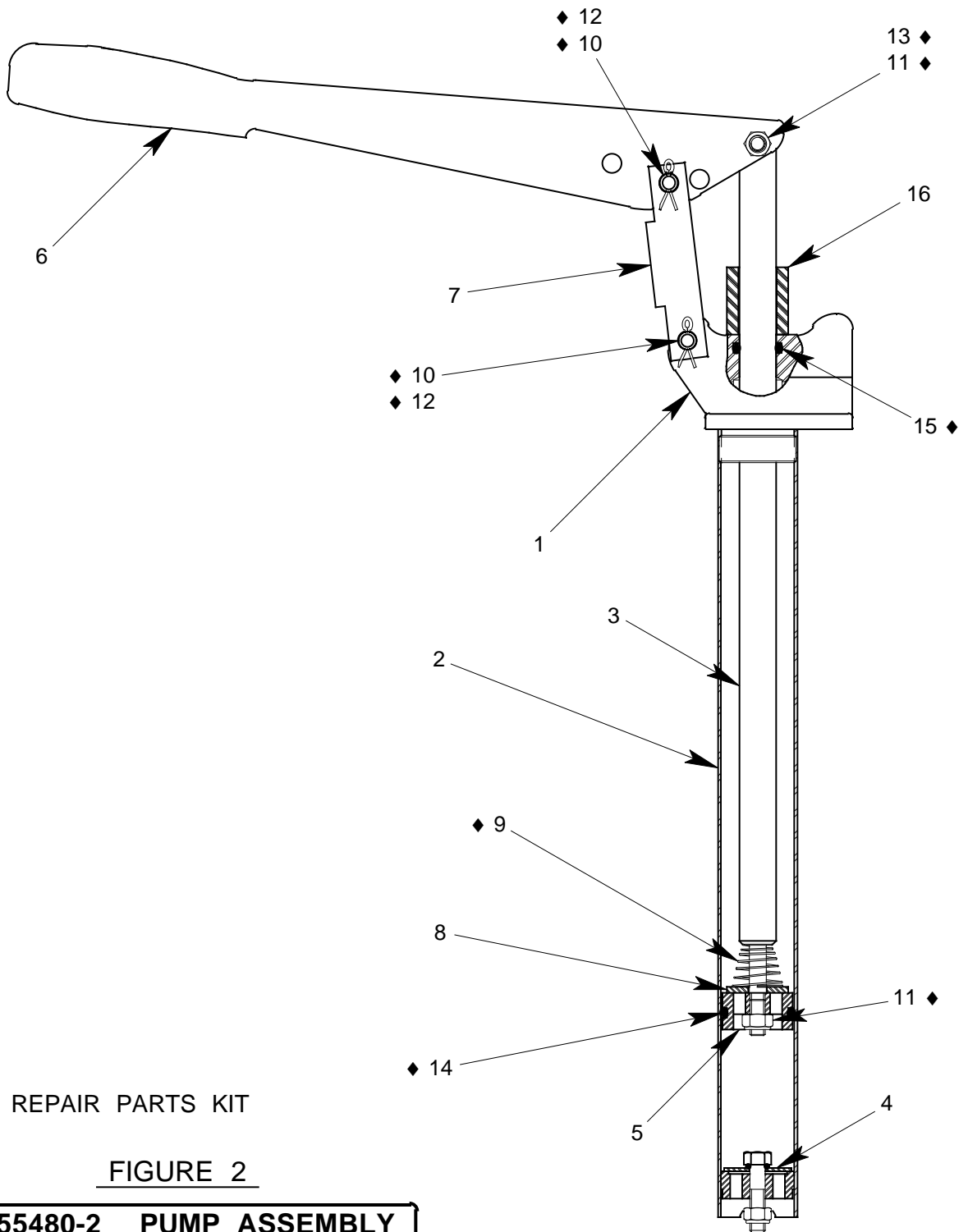

◆ PART OF REPAIR PARTS KIT

FIGURE 2

PF55480-2 PUMP ASSEMBLY

NO.	QTY	PART NO.	PART NAME	NO.	QTY	PART NO.	PART NAME
1	1	PF55466	PUMP BODY	9	1	PF53600	SPRING
2	1	PF53514	TUBE	10	2	PF53518	PIN
3	1	PF53515	PLUNGER ROD	11	2	355-021	SELF LOCK NUT, 5/16-24
4	1	PF53594	VALVE ASSEMBLY	12	2	372-001	COTTER PIN, 3/32 x 3/4 LG
5	1	PF53599	PLUNGER BODY	13	1	AN5-12A	HHCS, 5/16-24 x 1 11/32
6	1	PF53517	HANDLE	14	1	55925-218	O-RING
7	1	PF53533	LINK	15	1	55925-210	O-RING
8	1	PF53535	VALVE PLATE	16	1	PF55867	HANDLE STOP

PF5-5PK REPAIR PARTS KIT

QTY	PART NO.	PART NAME
1	PF55456	HOSE ASSEMBLY
1	481-006	FILTER ELEMENT
1	55925-025	O-RING
1	55925-329	O-RING
1	PF53602	PUMP GASKET
1	PF53600	SPRING
2	PF53518	PIN
2	355-021	SELF LOCK NUT, 5/16-24
2	372-001	COTTER PIN, 3/32 DIA x 3/4 LG
1	AN5-12A	HHCS, 5/16-24 x 1 11/32 LG
1	55925-218	O-RING
1	55925-210	O-RING
1	PF5-5PKDOC	REPAIR PARTS KIT LIST