



Operations Manual

Vehicle Types: XM20 and XM30 Models

This page intentionally left blank.

Table of Contents

Page	Description
4	Safety Warning
5	Welcome and Contact Information
6	Warranty Information
7	Vehicle Specifications
8	Putting Into Service
9	General Safety
10	Operator Requirements and Workstation
11	Pre-Operation Checklist
12	Startup/Shutdown and Safe Towing
13	Controls and Instrumentation
19	Cold-Weather Operation
20	Revision Log

Safety Warning



Read this manual in its entirety before putting your Eagle tow tractor into service. This manual contains important safety instructions. Improper usage or a failure to follow the safety requirements listed in this manual could result in severe injury or death.

CALIFORNIA

Proposition 65 Warning

Diesel engine exhaust and some of its constituents are known to the State of California to cause cancer, birth defects, and other reproductive harm.

Welcome and Contact Information

Welcome

Welcome to the growing family of Eagle tractor operators. This tractor was built with the operator's safety, comfort and ease of operation in mind. We hope you agree and enjoy your Eagle experience.

Purpose & Use of Manual

This manual is designed as a quick guide to familiarize you with the correct and safe operation of your Eagle tow tractor.

Your Eagle tractor was designed to do very specific tasks. For that reason, it will look, feel, drive and function differently than over-the-road trucks and automobiles, as well as various other types of vocational vehicles. It is the operator's responsibility to operate this equipment in a safe and prudent manner. Be alert; your safety and the safety of others is involved.

The descriptions and specifications contained in this manual were in effect at the time the manual was printed. Eagle Tugs reserves the right to discontinue models at any time and/or to change specifications, designs or components used without notice and without incurring obligations.

Contact Information

Corporate Offices
Sales, Support, Customer Service
 Eagle Industrial Truck
 26111 Northline Rd.
 Taylor, MI 48180
 USA
 (734) 442-1000 — (800) 671-0431

Website

www.eagletugs.com contains useful sales and service information. Please refer to this website for the latest revision of this and all other manuals.

Email Addresses

Customer Service	customerservice@eagletugs.com
Parts Department	parts@eagletugs.com
Technical Support	support@eagletugs.com
Sales Department	sales@eagletugs.com

Warranty Information

Warranty Registration

Please take the time to completely fill out the warranty registration information at our website www.eagletugs.com. It allows Eagle Tugs to contact the appropriate person(s) for future documentation updates, warranty notices, and safety bulletins.

Note: Eagle Tugs cannot start a warranty claim without a completed registration card.

Warranty

Please read the Eagle Tugs warranty statement (available on our website) carefully.

When contacting Eagle Tugs for warranty or parts service, please have the following information ready:

- Tractor model number
- Tractor serial number
- Current hour reading
- Maintenance and Service records

This information can be found on the data plate located beside the driver seat with the exception of the hours which can be read using the display on the dash.

Vehicle Specifications

Vehicle Specifications

Note: for full vehicle specifications refer to the Parts and Preventive Maintenance Manual section 9.

Tractor Model	GVW (lbs/kg)	Rated DBP (lbf/kN)	Vertical Hitch Capacity (lbf/N)	Towing Capacity† (lbs/kg)
XM-20	23,000 / 10.500	16,000 / 71	750 / 3300	210,000 / 95.000
XM-30	32,000 / 14.500	16,000 / 71	750 / 3300	215,000 / 97.500

† Towing Capacity applies to 1% grade, wet surface condition.

Engine Specifications

Note: for full vehicle specifications refer to the Parts and Service Manual section 9.

Engine Model	Emissions Rating	Power Rating (hp/kW)	Peak Torque (ft-lbf/N-m)	Fuel Sulfur Requirement (ppm)
Cummins QSF 2.8 T4f	EPA Tier4f / EU Stage 4	75 / 55	221 / 300	≤ 15
Cummins QSF Stage 3	EPA Tier3 / EU Stage 3A	72 / 54	199 / 270	≤ 2000

Putting Into Service

Unpacking and Setting Up

The following directions specify the correct steps that should be taken once you receive delivery of your XM series tow tractor. These steps will ensure that the tow tractor will operate safely. Reference the Parts and Preventive Maintenance Manual for details as appropriate.

- During the unloading of your tractor, note any shipping damage and report it to Eagle Tugs and the shipping company. Verify that all components appear to be in order and undamaged.
- Remove manual and any shipped-loose components from the operator compartment.
- Install shipped-loose components per the Parts and Preventive Maintenance Manual.
- Read this manual in its entirety, paying close attention to all safety requirements.
- Verify that tires are inflated to 145 psi / 1000 kPa.
- Fill the fuel tank with the appropriate diesel fuel.
- Check the following fluid levels:
 - Engine Oil
 - Hydraulic Fluid
 - Transmission Fluid
 - Coolant
- Familiarize yourself with the tractor operation and control.

General Safety

The following safety recommendations are not intended to cover all possible safety aspects of the XM series tow tractor. Please use common sense in addition to the safety recommendations that follow.



Warning: Failure to comply with the following safety precautions can result in serious injury or death as well as equipment damage.

- Always do the Pre-Operation Inspection before using the tractor.
- If you have not operated this equipment previously, practice driving and operating it in a safe and clear (not congested) area until you are familiar with all aspects of its operation.
- Always operate the tractor at a speed appropriate for the environmental conditions and the towed load. Slow down in congested areas, when moving a large load, or when conditions reduce traction or visibility.
- Always take care when driving on a slope or uneven ground. Reduce speed and take turns slowly in a controlled manner.
- When working on or around the tractor, take care to keep well clear of any moving components including tires, fans, belts, and driveshafts. Also keep clear of hot surfaces such as exhaust and cooling components.
- The XM series tractor features a braking system that utilizes accumulators for backup pressure. These accumulators store hydraulic fluid at pressures up to 3,000 psi. Take extreme care when working with the hydraulics to bleed the accumulator pressure down. Fully press and release the service brake pedal 15 times to bleed down the pressure.
- The XM series tractor is intended to be operated on hard improved surfaces. Never drive on soft surfaces, and avoid potholes and damaged pavement.
- The engine of the tractor emits potentially harmful gases when running. Always operate the tractor outdoors or in an environment with adequate ventilation.

Operator Requirements and Workstation

Operator Requirements

The XM series tow tractor is a piece of industrial equipment and has inherent safety risks. As such, the operator of the tow tractor is expected to have a fork truck or similar license, or be otherwise trained in the usage of material handling equipment.

The operator should read this manual in its entirety before operating the tow tractor.

The operator should be familiar with all aspects of the tow tractor before operating it.

Operator Workstation

Your XM series tow tractor features an ergonomically designed operator's workstation. This is the only operator workstation on the tractor. Do not sit on or stand on the tractor outside of this area during tractor movement.

The operator and any passengers should be seated with the seatbelt secured when moving or operating the tractor.

Keep arms and legs within the perimeter of the tractor's frame to avoid injury. Always place the tractor in Neutral and apply the parking brake before exiting the tractor.

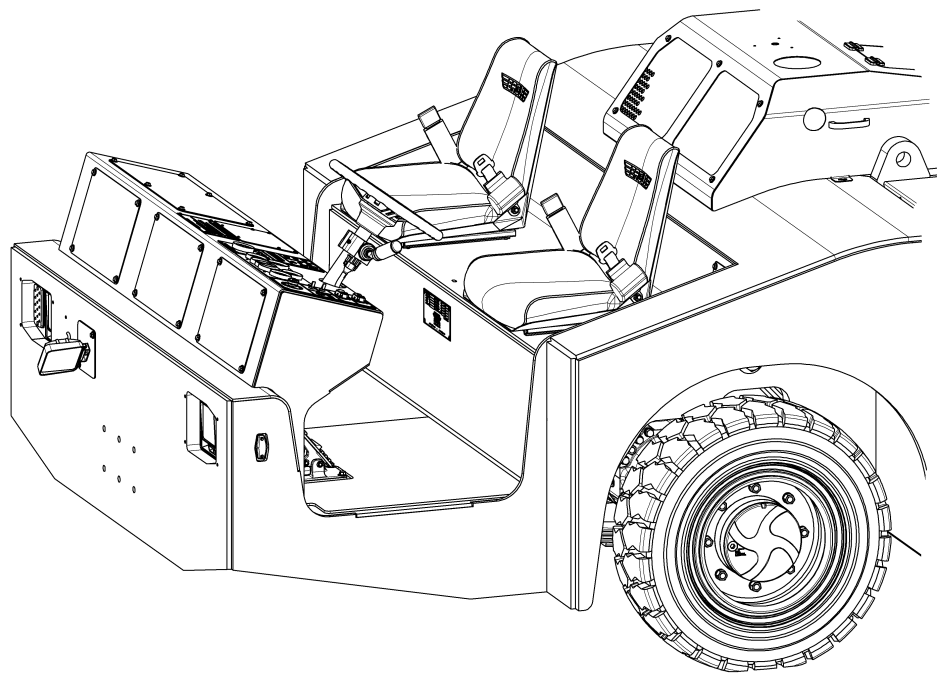

Operator Workstation

Pre-Operation Checklist

Pre-Operation Inspection Checklist

The following inspections should be conducted as stated below. Additional inspections may be required due to unusual operating conditions.

Daily Pre-Operation Checklist	Satisfac- tory	Service Required	Not Applicable
Walk-around inspection			
Verify no evidence of leaks under and around the tractor			
Verify fuel cap securely in place			
Visually verify tires are fully inflated			
Verify rims and tires free from damage including tire tread			
Verify tire tread is free from debris			
Verify lights, mirrors, and reflectors are clean			
Operational Checks (tractor engine running)			
Verify that the dash LED indicators are free of errors and warnings			
Verify that battery voltage is above 13V			
Verify that horn is operational			
Verify that lights, flashers, and beacon (if equipped) work properly			
Cab Inspection (if equipped)			
Verify windows clean			
Verify windows free of cracks and chips			
Verify windshield wipers operate properly			
Verify heater and fans operate properly			
Weekly Operation Checklist	Satisfac- tory	Service Required	Not Applicable
Walk-around inspection			
Verify tire inflation pressure at 145 psi / 1000 kPa			
Engine Compartment Inspection			
Check engine oil level (top off in necessary)			
Check engine coolant level (top off if necessary)			
Check hydraulic fluid level (top off if necessary)			
Check transmission fluid level (top off if necessary)			
Drain water from fuel/water separator			
Verify wiring, hoses, and tubing free of leaks and damage			
Remove dust from air cleaner dust valve			



Warning: Any problems noted during inspection should be corrected as soon as possible. Failure to promptly attend to problems could compromise safety and/or the tractor's performance. Do not attempt to make repairs. Contact a qualified mechanic.

Startup/Shutdown and Safe Towing

Starting the unit:

1. With feet firmly on the floor mat, adjust the seat to a comfortable position.
2. Sit in the operator seat and buckle the seat belt.
3. Verify that the gear selector is in the neutral position.
4. Start the engine with the ignition switch.
5. Select the desired transmission gear for the speed and drawbar requirements using the shift lever.
6. Select desired travel direction using the shift lever.
7. While holding the service brake pedal, press the parking brake engage/release button once to release the parking brake.
8. Verify that the intended path of the tractor is clear of obstructions and personnel and then proceed with driving.

Shutting down the unit:

1. Bring the tractor to a complete stop with the service brake.
2. Put the tractor in neutral using the shift lever.
3. Set the parking brake by pressing the parking brake engage/release button once.
4. Turn the tractor off by turning the ignition switch.

Load Towing and Pushing Safety

If towing or pushing a load, check to see that:

- The towed load is securely connected to the hitch of the tractor. Be sure hitch is locked/fastened into the closed position.
- For maximum tractor and load control and stability, as well as towing power, be sure the towbar is parallel to the ground when connected to the tractor's hitch.
- Ensure the plane or other towed load clears all obstacles when towing.

Controls and Instrumentation

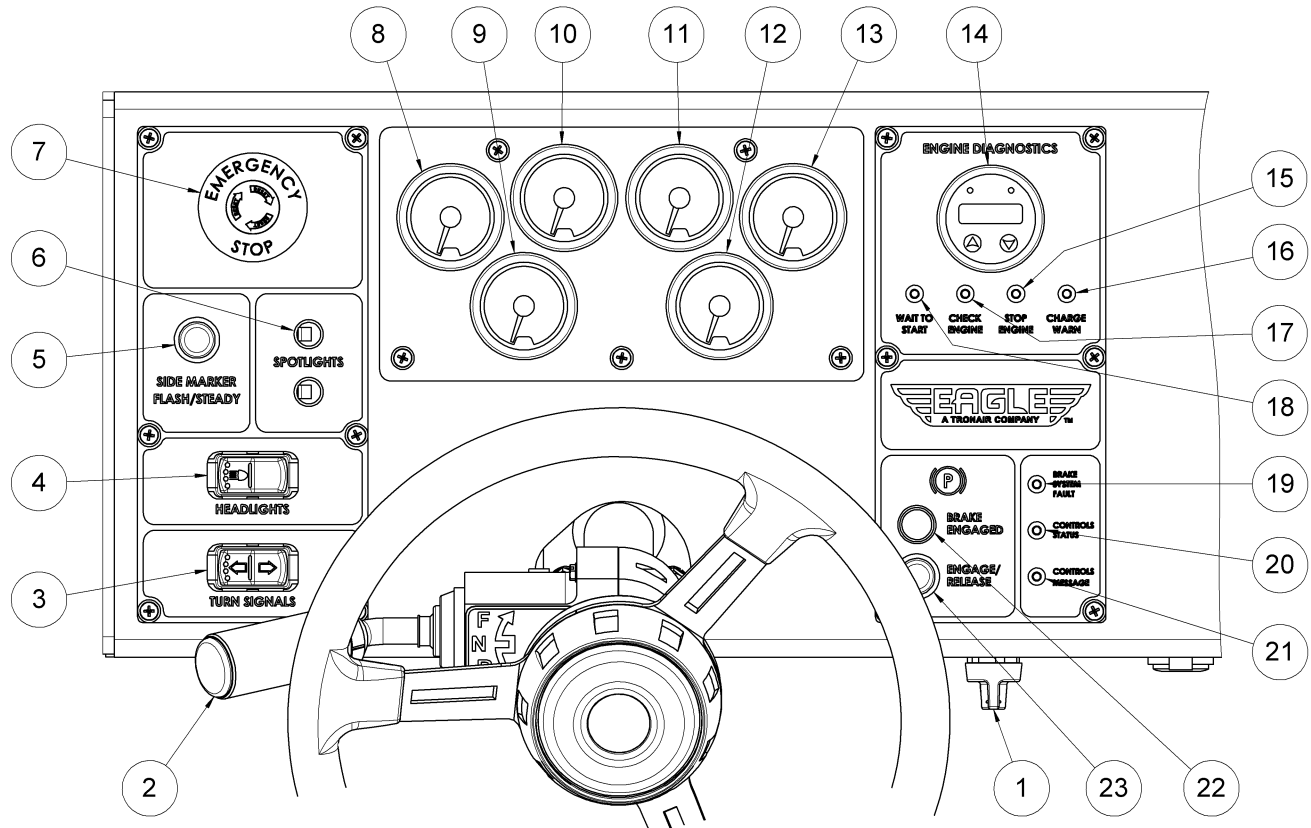

Item	Description
1	Ignition Switch
2	Transmission Shift Lever
3	Turn Signal Switch (Optional)
4	Headlight Switch
5	Side Marker Switch
6	Spotlight Switches (Optional)
7	Emergency Stop
8	Oil Pressure Gage (Optional)
9	Coolant Temp Gage (Optional)
10	Engine Tachometer (Optional)
11	Fuel Level Gage
12	Transmission Temp Gage (Optional)

Item	Description
13	Voltmeter (Optional)
14	Engine Diagnostics Display
15	Stop Engine Lamp
16	Charge Warning Lamp
17	Check Engine Lamp
18	Wait to Start Lamp
19	Brake Fault Lamp
20	Controls Status Lamp
21	Controls Message Lamp
22	Parking Brake Status Lamp
23	Parking Brake Engage/Release

Controls and Instrumentation

Ignition Switch

Your tractor is equipped with a keyed or keyless ignition switch. The switch provides power to the tractor and is used to crank the engine.

Transmission Shift Lever

The transmission shift lever is used to select the desired tractor gear (1 thru 3), and to select the desired travel direction (F N R). Changes to gear and directional selections can only be made when the tractor is at a stop. Changes made while moving will force the tractor to idle and not be effected until the tractor is brought to a stop.

Gear 1: Use this gear for maximum towing capacity. The top speed is 3.3 mph / 5.3 kph

Gear 2: Use this gear for light duty towing only. The top speed is 7.2 mph / 11.6 kph

Gear 3: Use this gear for unloaded operation only. The top speed is 15 mph / 24 kph

Turn Signal Switch (Optional)

The turn signal switch causes the front and rear signal lights on the tractor to flash. The signals are self-cancelling and work in one of three modes.

Mode 1 : Press turn signal button for 1 second, turn signal light will flash for 7 seconds, then self cancel.

Mode 2 : Press turn signal button for 2 seconds, turn signal light will flash for 20 seconds, then self cancel.

Mode 3 : Press turn signal button for 4 seconds, turn signal light will flash for 75 seconds, then self cancel.

All modes can be cancelled at any time by pressing the same turn signal button a second time

Note that turn signals will not self-cancel while the service brake is active.

Headlight Switch

The headlight switch is an on/off type. There is no hi/low beam control position.

Side Marker Switch

This switch controls the action of the marker lamps located on the corners of the tractor. The operator can select between solid or a safety flashing pattern. The selected pattern will be reflected by the backlight of the switch.

Spotlight Switches (Optional)

The spotlight switches are on/off types. The front and rear spotlights (if equipped) are controlled independently.

Controls and Instrumentation (Continued)

Emergency Stop

In the event of an emergency, the emergency stop button will shut down the engine of the tractor.

Note that the parking brake is a failsafe type brake and will automatically engage and bring the tractor to a firm stop when the emergency stop is activated.

Also note that steering functionality is greatly impeded when the engine is not running.

Oil Pressure Gage (Optional)

The oil pressure gage shows the current engine oil pressure as reported by the engine ECU.

Coolant Temperature Gage (Optional)

The coolant temperature gage shows the current engine coolant temperature as reported by the engine ECU.

Engine Tachometer (Optional)

The engine tachometer gage shows the current engine rotational speed as reported by the engine ECU.

Transmission Temperature Gage (Optional)

The transmission temperature gage shows the current transmission temperature.

Voltmeter (Optional)

The voltmeter gage shows the current tractor system voltage.

Engine Diagnostic Display (See appendix D for additional information)

The engine diagnostic display module has two functions

Parameter Display: The display module by default will show the following engine parameters. Additional parameters can be enabled through the menus.

- Engine Speed
- Oil Pressure
- Coolant Temperature
- System Voltage
- Engine Hours

J1939 Diagnostics: If an engine warning or error is active, the display module will show the SPN (Suspect Parameter Number), FMI (Failure Mode Identifier), and OC (Occurrence Count). These numbers can be cross referenced with a troubleshooting list to diagnose and correct engine issues.

Controls and Instrumentation (Continued)

Fuel Level Gage

The fuel level gage shows the current fuel level in the fuel tank.

Stop Engine Lamp

The stop engine lamp illuminates when a condition is detected that could cause damage to the engine (over-temp, low coolant, etc.). Should this occur, the engine should be shut down as soon as possible. Note that in some cases after the stop engine lamp is illuminated, the engine will shut down on its own to protect itself. An illuminated stop engine lamp will be accompanied by a J1939 error code on the engine diagnostic display to assist in troubleshooting.

Charge Warning Lamp

The charge warning lamp is illuminated any time the alternator is not charging properly. If the engine is running and the charge warning lamp illuminates, the charge system (alternator, battery, and battery cables) should be inspected by maintenance personnel. Continued usage with a faulty charging circuit will lead to a dead battery.

Check Engine Lamp

The check engine lamp is illuminated to indicate an engine error that needs to be resolved. Have the tractor inspected by maintenance personnel at the earliest convenience. An illuminated check engine lamp will be accompanied by a J1939 error code on the engine diagnostic display to assist in troubleshooting.

Wait to Start Lamp

The wait to start lamp is illuminated to indicate that the engine pre-heat is active. Wait until the lamp goes out before starting (cranking) the tractor.

Brake Fault Lamp

The brake fault lamp is illuminated when there is insufficient pressure in the service brake circuit to provide safe operation. The tractor will automatically be forced to idle if this error is active. The tractor should be removed from service immediately to prevent unsafe operation and inspected by maintenance personnel.

Controls Status Lamp

The controls status lamp is illuminated green when there are no active issues with the tractor control system. When the controls status lamp is off, the tractor requires operator intervention (see the Controls Message Lamp).

Controls and Instrumentation (Continued)

Controls Message Lamp

The controls message lamp is used to communicate tractor control system messages to the operator. The lamp, when active, has two modes.

Steady On: A controls change was made outside of allowable parameters. For instance, the transmission shift lever was moved from Forward to Reverse without coming to a stop. When the controls change is effected or the controls are returned to the correct position the lamp will turn off.

Warning Message: The controls message lamp can display a blink code for many tractor issues and warnings. Blink codes are all two digits. There is a short pause between digits and a long pause between codes.

The current list of available codes is provided below. See the troubleshooting section of the parts and preventive maintenance manual for additional details.

- 21: J1939 CAN address claim fault
- 22: Throttle sensor primary wiper fault
- 23: Throttle sensor secondary wiper fault
- 24: Front axle disconnect solenoid fault
- 25: First gear solenoid fault
- 26: Fuel level sensor fault
- 27: Forward solenoid fault
- 28: Hydraulic fluid over temperature
- 29: Throttle wiper coordination fault
- 31: Reverse solenoid fault
- 32: Parking brake solenoid fault
- 33: Second gear solenoid fault
- 34: Transmission cold temperature interlock active
- 35: Transmission over temperature
- 36: Transmission temperature sender fault
- 37: Hydraulic temperature sender fault
- 39: Hydraulic fluid low
- 41: Sensor power fault
- 42: J1939 CAN fault
- 43: Throttle pedal calibration needed (primary wiper)
- 44: Throttle pedal calibration needed (secondary wiper)
- 45: Low brake accumulator pressure

Controls and Instrumentation (Continued)

Parking Brake Status Lamp

The parking brake status lamp is illuminated when the tractor is on and the parking brake is engaged (brake is on). No movement of the tractor is permitted with the brake engaged.

The parking brake will always be engaged when the tractor is first started.

Parking Brake Engage/Release Switch

The parking brake engage/release switch will engage or release the parking brake.

To release the parking brake, the following condition must be met:

- Service brake pressed
- Throttle pedal at idle

To engage the parking brake, the following conditions must be met:

- Service brake pressed
- Throttle pedal at idle
- Tractor speed below 0.5 mph / 0.8 kph

Attempting to engage the parking brake when the required conditions are not met (while driving at speed) will force the tractor to idle and neutral, which will bring it to a rolling stop (pressing the button additional times will not have any effect). Once stopped, the parking brake will engage. At this point normal operation can be resumed.

Cold-Weather Operation

Engine Cold Start Assist

When the engine coolant or air intake temperature is below 32°F / 0°C, the tractor will have a delay on startup while the air heater pre-heat is active. The wait to start lamp will illuminate during this time. When the wait to start lamp goes out, it is okay to start the engine.

For extreme cold weather operation an optional engine block heater is available. The optional block heater uses wall outlet power to pre-heat the engine block to make cold-weather starting easier.

Transmission

When the transmission fluid temperature is below minimum operating temperature (15°F / -10°C), the engine will be forced to idle until the transmission reaches operating temperature. During this time, the controls message lamp will blink message “34” and the throttle will be forced to idle. Once the transmission reaches operating temperature the blink code will discontinue and the controls status lamp will illuminate green. At this point normal operation can be resumed.

For extreme cold weather operation, a sump cartridge heater may be required. Contact Eagle Tugs for more information.

Revision Log

Rev	Date	Description	Appr.
A	02-Jun-2016	Original release for production	PRB