

EZ Load™ Service Trailer

Model 8784B



The Model 8784B EZ Load Service Trailer is designed for transporting aircraft tires, axle jack, wheel brake changer and brake cradle. This trailer raises and lowers via nitrogen supplied lift actuators for easy loading and unloading of tires and equipment. There is a tow pintle rated for 200 pounds tongue load and 2000 pounds tow load which can be used for extra towing. The unit is equipped with tow handle & integral front wheel parking brake, four 21 inch diameter poly filled tires, tool box, control panel air inlet and three lift actuators.

Model 8784B is built to withstand harsh environmental conditions, rugged use and to provide many years of continuous service. Our customers are guaranteed a quality product with each purchase and are assured of our continued product support whenever and wherever the need arises.

Standard Features:

- Self-contained lift system to raise and lower trailer bed for easy load and unload operations. Lift system utilizes an on board nitrogen bottle (2400 psig or 3600 psig) and pneumatic lift actuators
- Conveniently located control panel with system pressure gauges (to monitor system operation) and safety relief valve
- Single valve control located on control panel raises, lowers or maintains position of trailer bed
- High capacity 6.00 x 9 (21 inch diameter) poly filled tires eliminate flats due to punctures and provide a cushioned rise
- 12 inch x 11 inch x 57 inch long storage box for landing gear hand tools
- Aircraft tire restraint chains and equipment tie down straps and padeyes
- Auxiliary tow pintle
- Heavy duty tubular steel construction with bar grating to reduce slipping on trailer bed surface

Standard Features (Cont'd)

- Rugged large diameter tubular steel tow handle with integral adjustable parking brake and 3 inch lunette eye
- All unpainted parts are plated to resist corrosion
- Skydrol resistant paint (safety yellow)
- Shipment on domestic skid
- 1 year standard warranty

Optional Features:

- Two extra tow pintles
- Cover for control panel
- Side chains for jack compartments
- Aircraft tire service regulator and hose assembly
- Aircraft tire service regulator and hose reel
- US DOT standard 3600 psig nitrogen bottle
- Customer specified paint color
- Export crating

EZ Load™ Service Trailer

Model 8784B

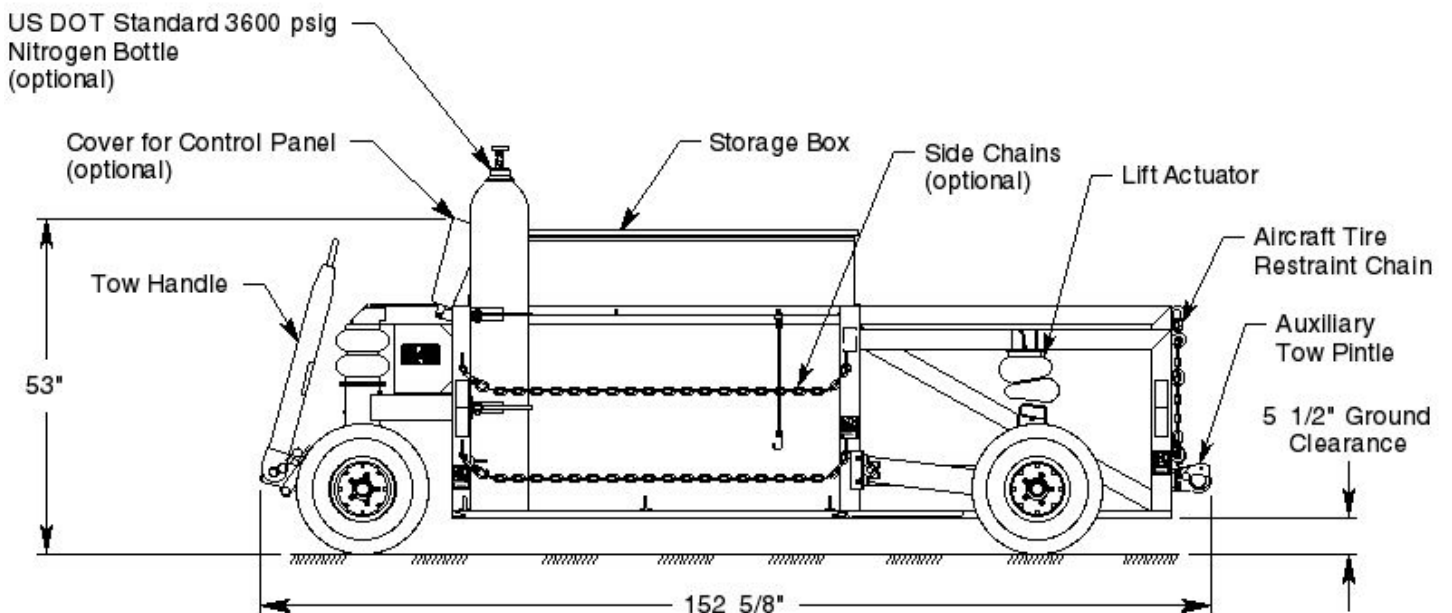
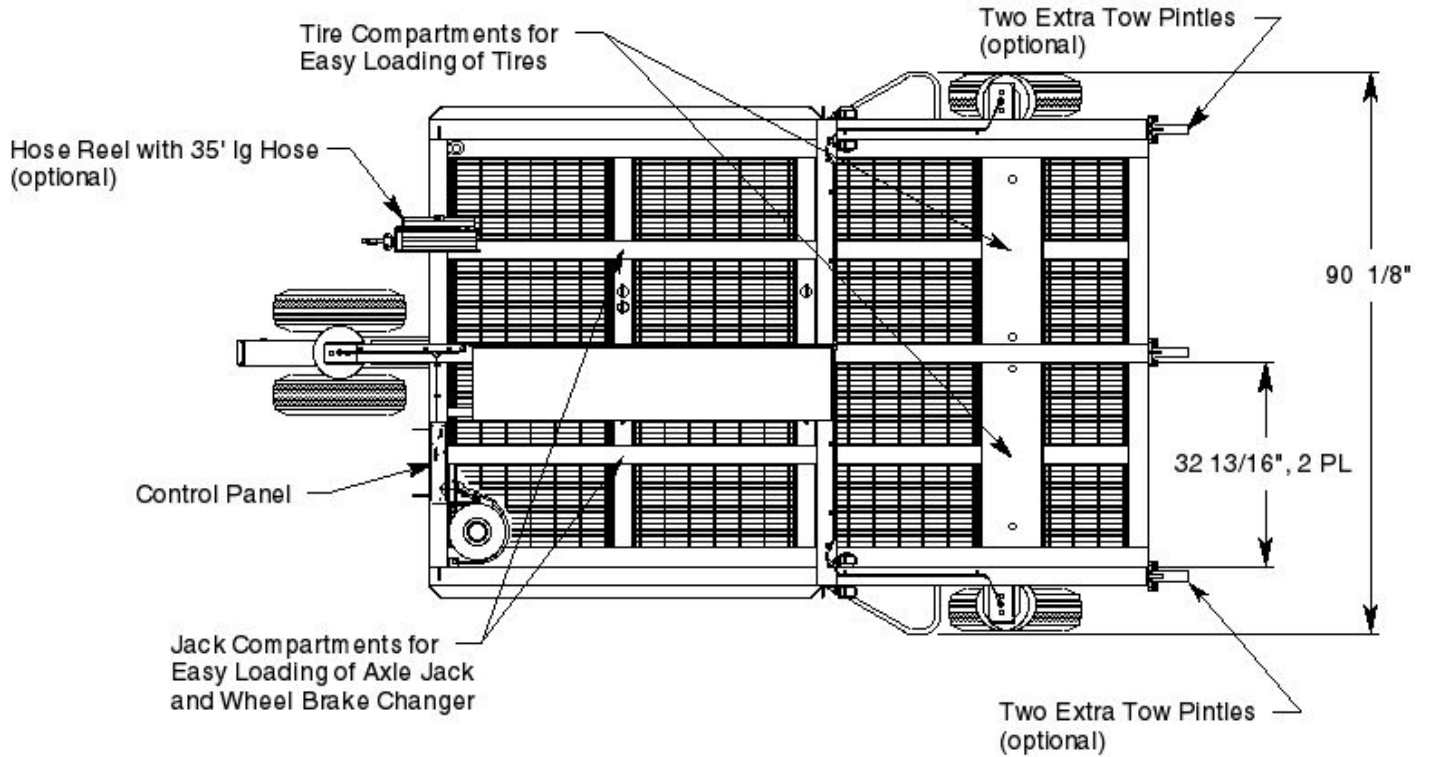

For more information contact: sales@malabar.com

EZ Load™ Service Trailer

Model 8784B

Specifications:

Maximum Aircraft Tire Size.....	56 inches (1422 mm)
Trailer Bed Raise/Lower Cycles:	
2400 psig Nitrogen Bottle	70
3600 psig Nitrogen Bottle	80
Trailer Bed Lift/Lowering Speed	15-20 seconds
Actuator Minimum Operating Pressure	100 psig (7 kg/sq cm)
Auxiliary Tow Pintle Maximum Tongue Weight	200 lbs (91 kg)
Auxiliary Tow Pintle Maximum Tow Weight.....	2000 lbs (907 kg)
Maximum Towing Speed	20 mph (32 km/h)
Trailer net Weight (empty)	1560 lbs (708 kg)
Trailer Gross Weight (fully loaded)	3770 lbs (1710 kg)

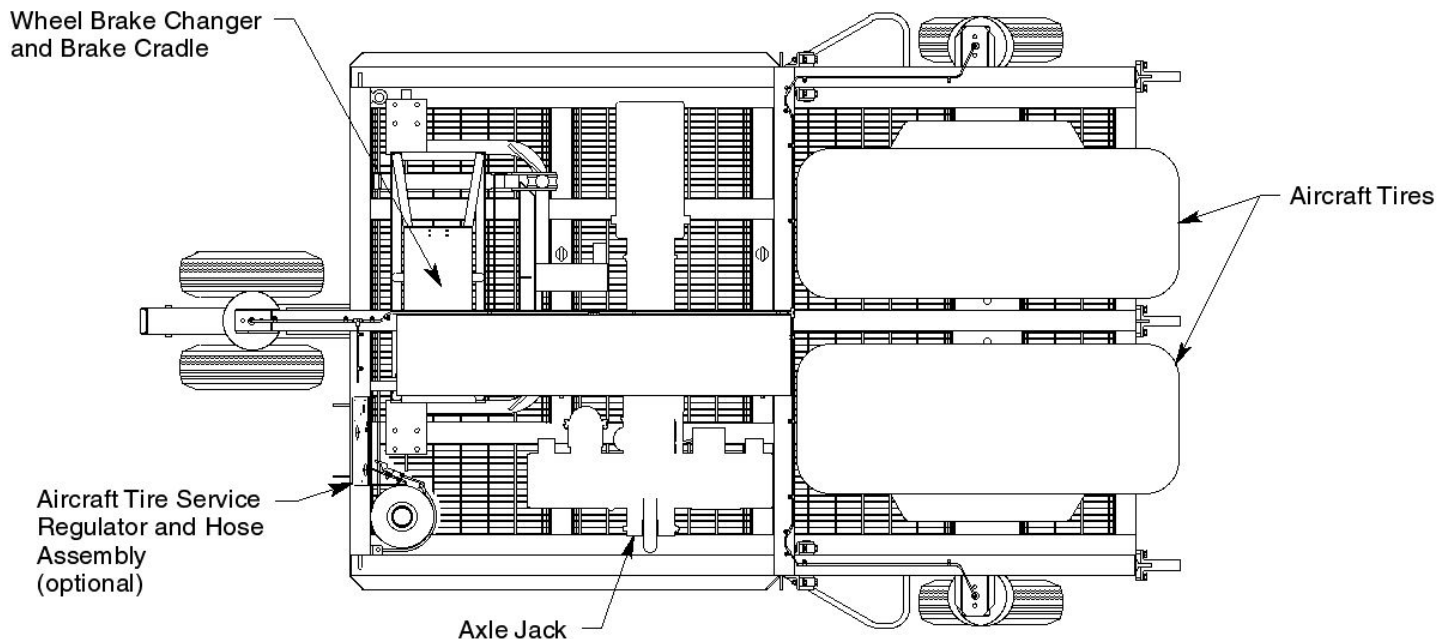

Optional Equipment Codes:

(Specify with order)

- PH: Two Extra Tow Pintles
- PC: Panel Cover
- SC: Side Chains
- TS: Aircraft Tire Service Regulator and Hose Assembly
- TSHR: Aircraft Tire Service Regulator and Hose Reelsd8784B
- NB: US DOT Standard 3600 psig Nitrogen Bottle
- SPC: Special Paint Color

EZ Load™ Service Trailer

Model 8784B

Packaging Codes and Options:

(Specify with order)

- : Domestic Skid
- EC: Export Crate (Additional Cost)

Shipping Data:

NOTE: Unless otherwise specified, Model 8784B is shipped on a wood skid.

Packaging Code	Length inches (mm)	Width inches (mm)	Height inches (mm)	Weight lbs (kg)
-	156 (3962)	91 (2311)	56 (1422)	2100 (953)
EC	158 (4013)	95 (2413)	59 (1499)	2400 (1089)